

# TROPICAL SUNSHINE

OCTO1

# ASSEMBLY INSTRUCTIONS



About wood



See more



User guide



**Lisez les instructions et le guide de l'utilisateur avant de procéder à l'installation !**

CODE QR pour Le Guide



EN

PL

FR

DE



#### AVANT L'INSTALLATION

Les instructions que vous avez en main vous montrent, étape par étape, comment installer correctement votre piscine. Nous nous sommes efforcés de préparer des documents qui reflètent le plus fidèlement possible l'état réel et l'aspect des différents éléments. Cependant, veuillez noter que tous les dessins ne sont donnés qu'à titre d'illustration et qu'il est possible que les éléments individuels fournis dans votre kit diffèrent en fait de leur visualisation graphique contenue dans les instructions.

Suivez les règles pour une utilisation de la piscine en toute sécurité !

Avant l'installation, stockez l'emballage dans un endroit sec avec une circulation d'air adéquate, protégez-le des conditions atmosphériques dommageables (soleil, précipitations). Ne pas stocker sous abri à la lumière directe du soleil. Conservez soigneusement les éléments en bois non emballés sans les exposer à la lumière directe du soleil ou à l'eau.

Installer dans les 3 jours suivant le déballage de la structure.



Afin de protéger le bois contre les conditions atmosphériques, nous recommandons de finir la surface en bois de la piscine avec des préparations conçues pour protéger les structures externes en bois (par exemple, le vernis à l'huile disponible dans notre offre actuelle - le produit spécialement conçu pour une protection efficace des piscines en bois). L'entretien de la piscine doit être effectué au moins une fois par an, et dans le cas des piscines soumises à des conditions atmosphériques extrêmes, même plus souvent.

**L'absence d'entretien annuel de la structure annule la garantie !**



Avant l'installation, vérifiez soigneusement la quantité et que les éléments ne sont pas endommagés. Les différents raccords indiqués dans les instructions peuvent différer légèrement de ceux qui sont effectivement fournis. Toute défectuosité ou tout dommage doit être signalé avant l'installation.



Préparez les outils nécessaires indiqués dans les instructions - les outils ne sont pas inclus dans le kit.



### **BOUCHON DE LA BUSE**

Pour préparer la piscine pour l'hiver (surtout s'il y a un risque de gel de l'eau), utilisez un bouchon pour les buses d'entrée afin de couper l'alimentation en eau du groupe de filtration. Laissez la buse dans la piscine, installez le bouchon sous l'eau. N'oubliez pas non plus de débrancher le jeu de filtres de la source d'eau et de sécher soigneusement la buse de l'extérieur. Il est également conseillé d'éliminer toute l'eau résiduelle de la pompe et du filtre à sable qui y est attaché pendant la période hivernale (endroits où il y a le risque de gel), sinon l'eau gelée peut détruire l'ensemble.



### **PRÉPARATION DU SOL**

La structure d'une piscine entièrement ou partiellement enterrée dans le sol doit être protégée conformément aux directives des instructions.

Une protection conforme au dessin des instructions est nécessaire :

- 1 - FONDATION DE LA PISCINE**
- 2 - TUYAU DE DRAINAGE**
- 3 - PROTECTION DE SOUBASSEMENT**
- 4 - GRAVIER**
- 5 - GÉOTEXTILE**
- 6 - SOL**

Pour délimiter la zone de la piscine, on pose une première couche, que l'on enlève ensuite pour préparer le terrain.

Lorsque vous délimitez l'emplacement de votre piscine, enlevez l'herbe, les racines et les pierres.

Le sol sous la piscine doit être ferme, plat et de niveau !

Dans le cas de piscines sans supports en acier - utiliser du sable stabilisé au ciment (couche - 2 cm) ou une chape en béton.

Dans le cas d'une piscine avec des supports en acier - la base de la fondation / la chape de béton doit être préparée conformément au schéma figurant dans les instructions.

Les directives pour le positionnement des poteaux 2T et la préparation de l'armature pour la chape doivent être strictement respectées, toutes les dimensions doivent suivre les directives trouvées dans le manuel.

Nous recommandons que la chape de béton soit réalisée par des entreprises spécialisées.



## INSTALLATION DE LA STRUCTURE EN BOIS

Commencez à installer la structure avec la première couche.

Vérifiez les diagonales après la pose de chaque couche, les dimensions doivent être conformes aux instructions.

Lors de la pose des couches successives, utiliser la cale de frappe fournie avec les éléments en bois de la structure. L'impact direct sur les éléments de la languette ou de la rainure n'est pas autorisé. Les dommages qui en résultent rendent impossible l'assemblage des composants ou affaiblissent leur résistance.

Continuez à assembler les différentes pièces de bois dans l'ordre indiqué dans les instructions.

**OPTION** → Si votre piscine est équipée d'une option d'éclairage, installez la lampe dans la structure de la piscine selon les instructions supplémentaires fournies avec la lampe.



## PRÉPARATION DE L'ÉCUMOIRE

Assemblez les différents éléments pour former une écume complète, en fixant les filets avec du ruban en téflon.

### Attention !

Le temps d'installation de l'écume dans la structure en bois dépend du modèle de l'écume. Effectuez cette étape conformément aux consignes figurant dans les instructions de votre piscine.

L'écume doit être vissée à l'étape appropriée et aux endroits indiqués.

Lors de l'installation, les surfaces du diffuseur doivent être recouvertes de ruban adhésif double face et le joint doit être collé en place.



## PRÉPARATION DE L'INTÉRIEUR DE LA PISCINE

Installez le géotextile à l'aide de ruban adhésif double face ou de colle. Commencez par les parois intérieures de la piscine. Préparez les trous pour l'écume et les buses dans le géotextile uniformément réparti.

Découpez les profilés de fixation de la membrane de piscine aux dimensions indiquées, en veillant à respecter les angles requis. Faites des trous de  $\varnothing$  2 mm dans les profilés comme indiqué. Ajustez ensuite les profilés à la structure en les joignant autour du périmètre de la piscine. N'oubliez pas que les profilés sont assemblés dans le sens de la longueur, et que vous devez donc prévoir le moins de joints possible.

Étalez le géotextile uniformément sur la base de la piscine, puis commencez à installer la membrane (le liner) dans les profilés en PVC.

Stockez la membrane de piscine emballée dans un endroit sec à une température ambiante de 15-25 degrés Celsius avant de l'installer. La température chaude rendra le matériau plus facile à ajuster et à installer dans la structure

Ajustez soigneusement les coins du film de piscine aux coins de la piscine. Lissez les plis éventuels. Faites attention aux zones autour des trous pour la lampe, la buse, l'écumoire.

Installez la membrane de piscine dans les profilés en PVC en appuyant avec le joint (un bouchon).

Au moment de verser l'eau, étalez le revêtement sur le sol, pieds nus, en aplanissant les plis, tout en étirant les parois jusqu'au sol (en faisant particulièrement attention aux angles).

L'eau de la piscine doit être complétée progressivement comme indiqué dans les instructions.



### **SYSTÈME DE FILTRATION**

Arrêtez le remplissage d'eau 5-10 cm avant l'endroit prévu pour la buse et découpez le trou pour la buse comme indiqué dans les instructions.

Lubrifiez les joints du côté du revêtement avec de la vaseline, fixez les buses, couvrez les filets de la buse avec du ruban en téflon, puis fixez le tuyau à la buse et attachez-le avec des serre-joints à vis sans fin. Ajustez la pression avec précaution pour ne pas casser le serre-joint, observez s'il y a des fuites. En cas de manque d'étanchéité, appliquez plus de ruban adhésif et resserrez le serre-joint.

Remplissez le réservoir du filtre à moitié avec de l'eau. Remplissez l'autre moitié du réservoir du filtre avec le sable inclus dans le kit.

Assemblez le kit de filtration composé de la valve, du collier et du manomètre. Recouvrez les raccords de tuyaux de ruban en téflon aux points de filetage et de raccordement des tuyaux.

Raccordez les éléments du système de filtration conformément aux instructions de votre modèle.

Continuez à remplir d'eau après cette étape



### **INSTALLATION DE L'ECUMOIRE**

Arrêtez de verser l'eau lorsque le niveau d'eau atteint 5 à 10 cm en dessous de l'endroit désigné pour l'écumoire afin de découper un trou dans la membrane pour l'écumoire. N'oubliez pas de découper au préalable des trous dans le géotextile sous la membrane de la piscine.

Installez le cadre de l'écumoire à l'intérieur et vissez-le doucement à l'extérieur de l'écumoire à travers la membrane pour faciliter le marquage de l'emplacement de la découpe. Ne coupez pas la membrane avant de visser le cadre, la coupe pourrait se déplacer et le trou fait pourrait ne pas être adapté lorsque le cadre sera vissé.

Découpez le trou, puis retirez le cadre, en installant les autres éléments de l'écumoire à sa place. Joint, cadre et grille. Suivez l'illustration dans les instructions.

Assurez-vous que vous avez connecté tous les éléments de filtration avec les tuyaux selon les instructions et continuez à remplir d'eau.

Pour garantir le bon fonctionnement du groupe de filtration, remplissez le niveau d'eau de la piscine jusqu'au milieu de l'écumoire !



### INSTALLATION DE PLANCHES DE TERRASSE

Posez les planches de la terrasse de la piscine conformément au schéma figurant dans les instructions.

Utilisez les charnières incluses pour monter le panneau mobile afin d'accéder à l'écumoire.



Installez les connecteurs d'angle sur la face inférieure des planches de terrasse.

Pour améliorer l'esthétique, il est recommandé d'enlever et de replacer les planches de terrasse dans les 1 à 2 semaines suivant le remplissage de la piscine.

Veillez à ce que les vis de terrasse soient régulièrement espacées.

Une fois le montage des planches de terrasse terminé, procédez à l'installation de l'escalier extérieur et de l'échelle intérieure.

**OPTION** → Si votre piscine dispose de l'option de grilles d'angle, effectuez leur installation comme indiqué dans els instructions.

**PL** Instrukcja montażu

**GB** Assembly instructions

**DE** Montageanleitung

**FR** Notice de montage

**IT** Istruzioni di montaggio

**NL** Montage-instructies

Nazwa /Name /Name /Nom /Nome /Namm

# OCTO 1

UWAGA /REMARQUE/ /NOTE/ ATATTENZIONE /HINWEIS /LETOP

**PL** Maksymalna wysokość słupa wody ~ 1,00 m

**FR** Niveau maximum de la colonne d'eau ~ 1,00 m

**GB** The maximum water column level ~ 1,00 m

**IT** Livello massimo della colonna d'acqua ~ 1,00 m

**DE** Maximaler Wasserstand ~ 1,00 m

**NL** Maximum niveau waterkolom ~ 1,00 m

**PL** Objętość wody w basenie 9,98 m<sup>3</sup>

**FR** Le volume de l'eau dans la piscine 9,98 m<sup>3</sup>

**GB** Water capacity in the pool 9,98 m<sup>3</sup>

**IT** Il volume di acqua in piscina 9,98 m<sup>3</sup>

**DE** Volumen von Wasser im Schwimmbecken 9,98 m<sup>3</sup>

**NL** Water inhoud van het zwembad 9,98 m<sup>3</sup>

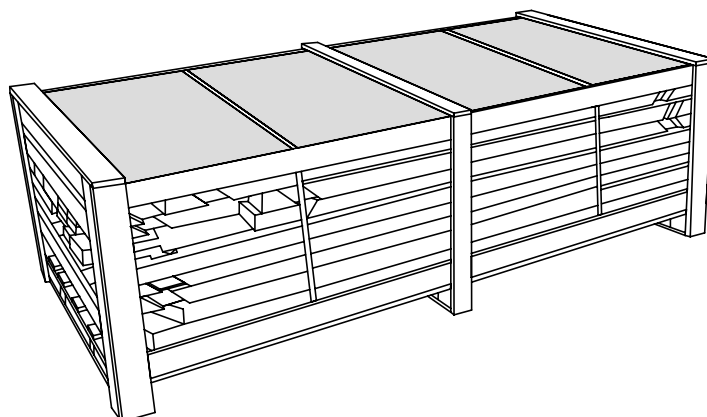
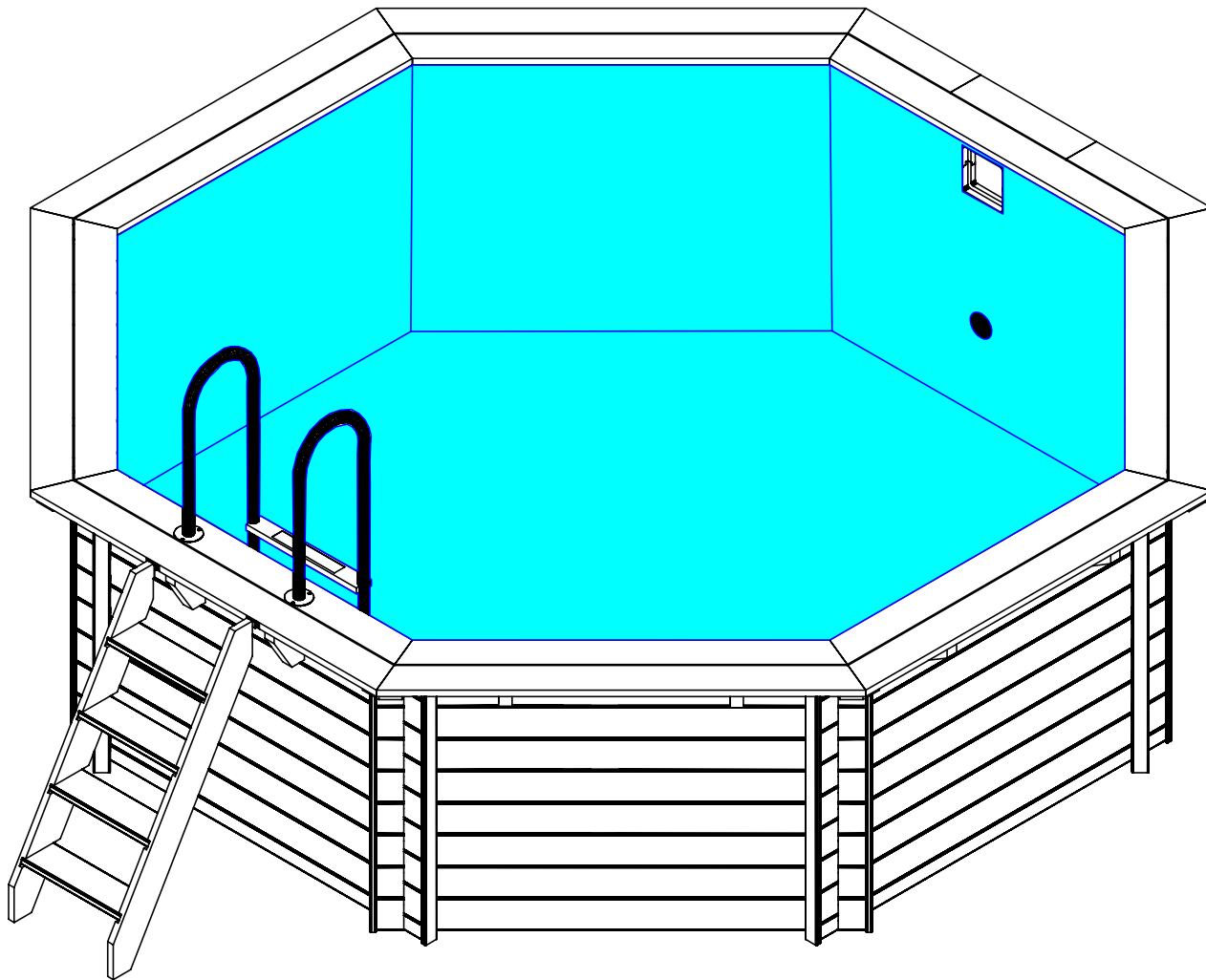

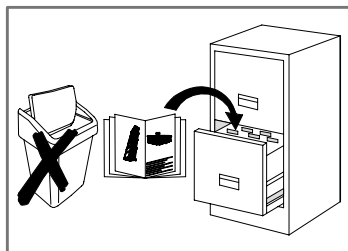
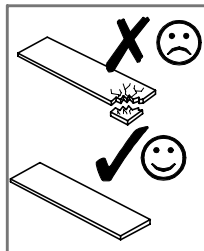
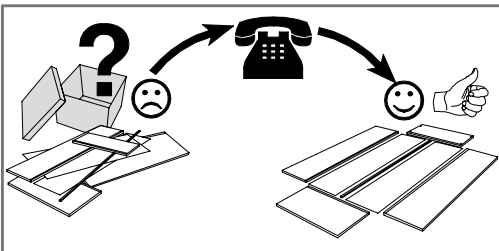
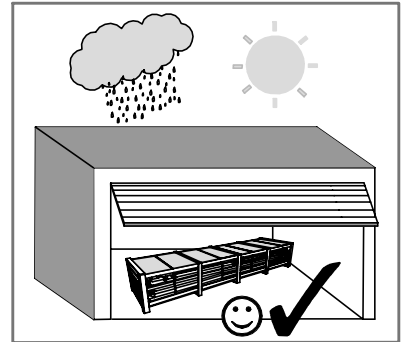
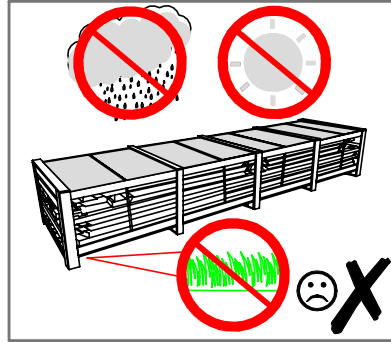
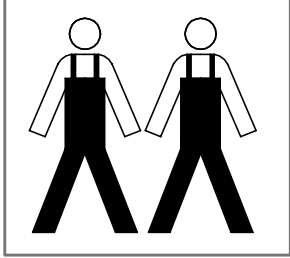
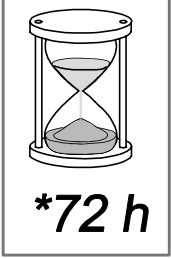

REGULAR MAINTENANCE



VERY IMPORTANT!



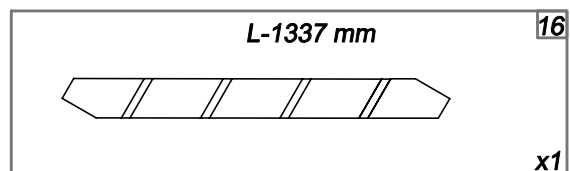
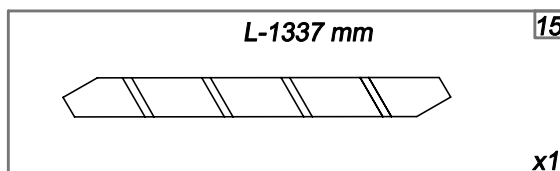
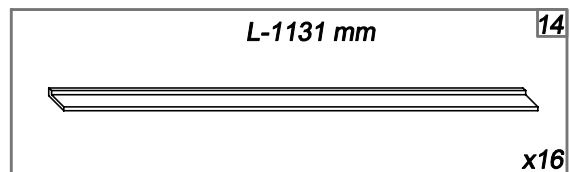
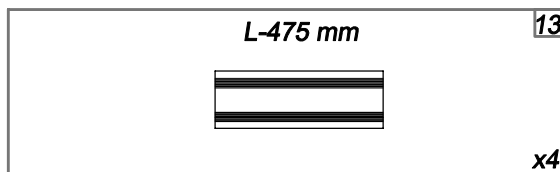
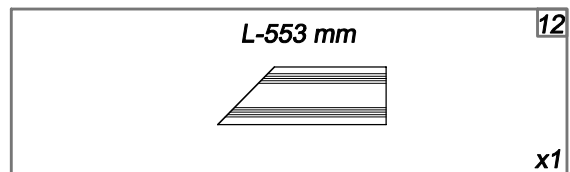
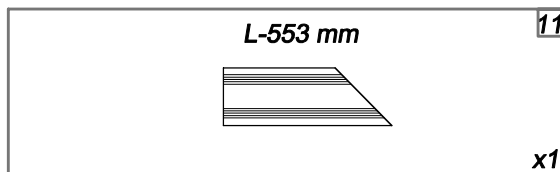
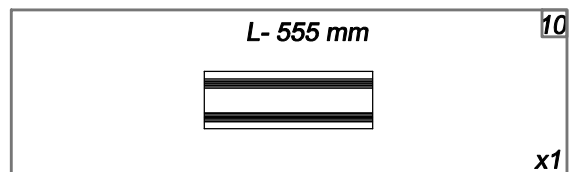
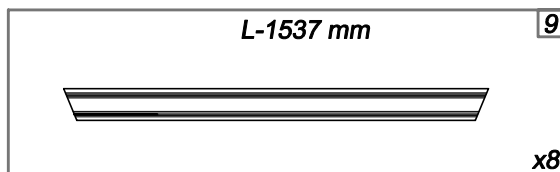
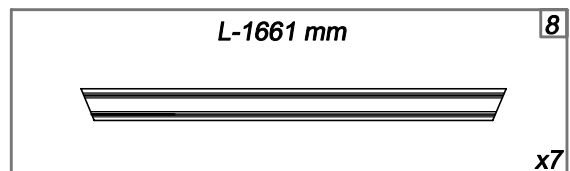
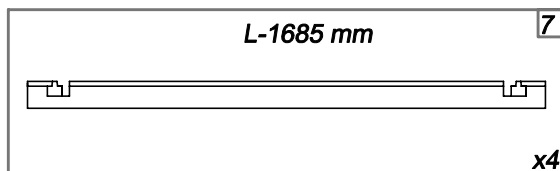
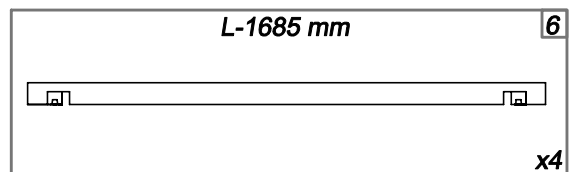
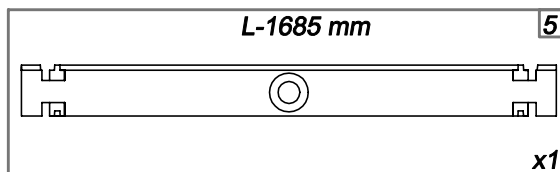
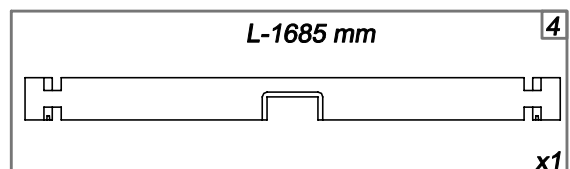
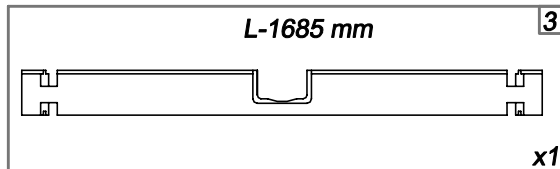
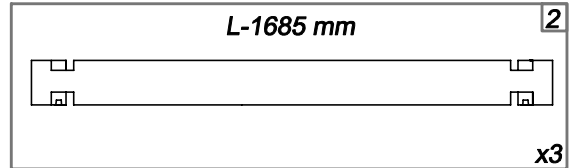
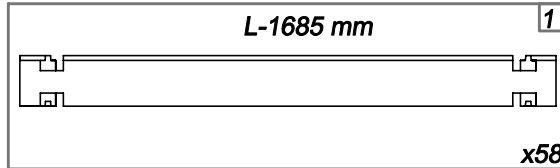
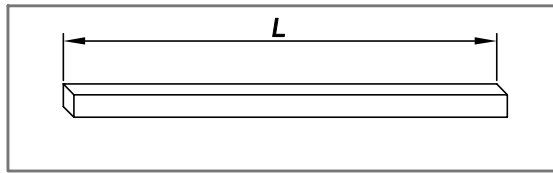

PL Elementy

GB Elements

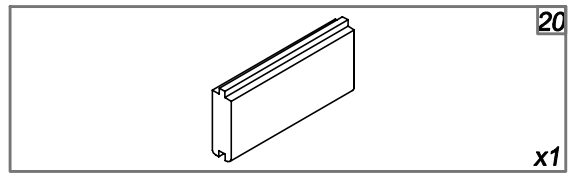
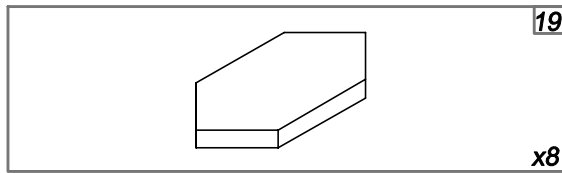
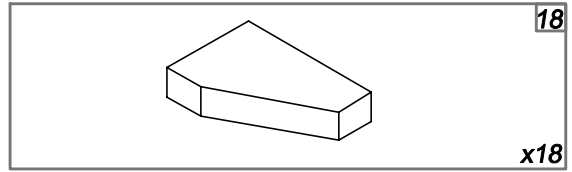
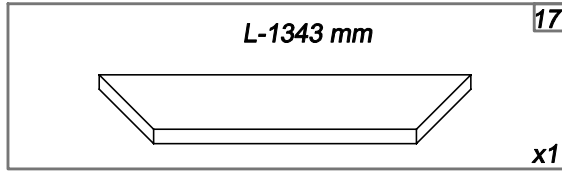
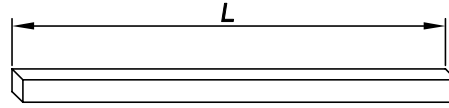

PL Elementy

GB Elements

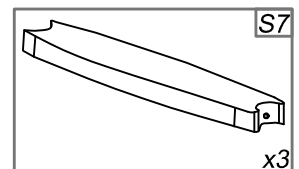
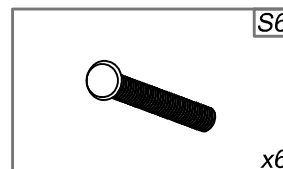
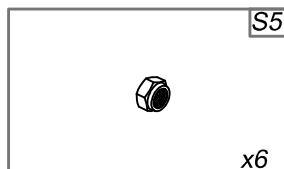
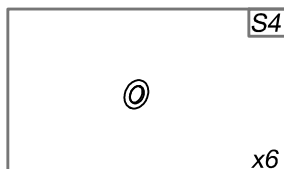
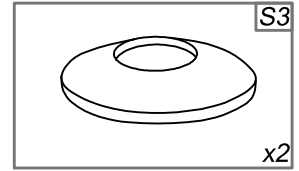
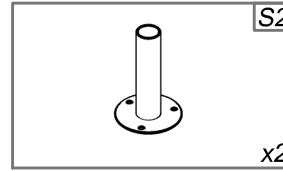
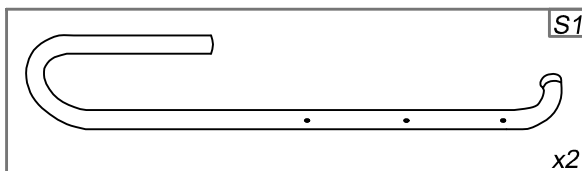
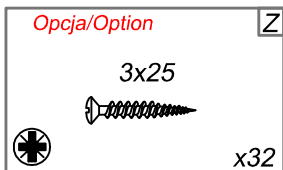
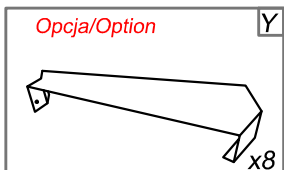
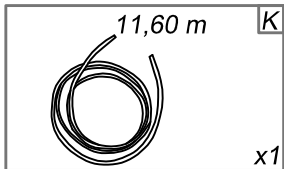
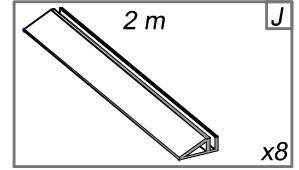
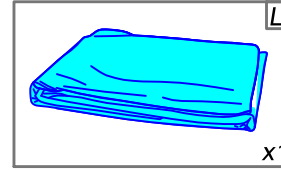
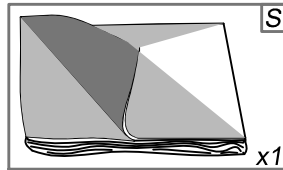
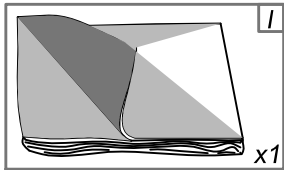
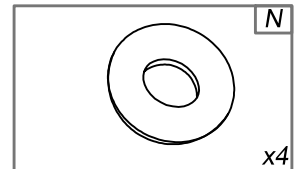
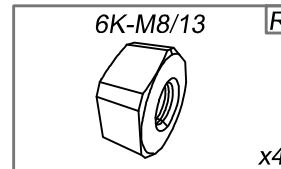
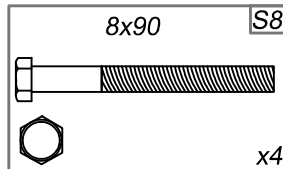
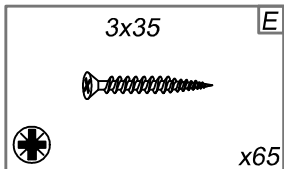
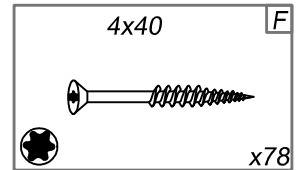
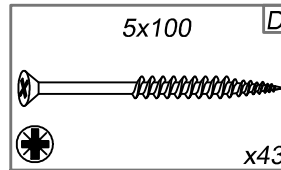
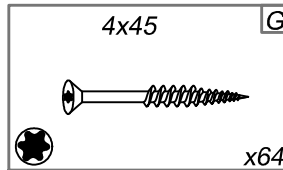
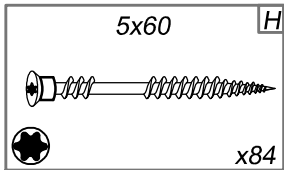
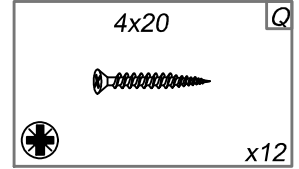
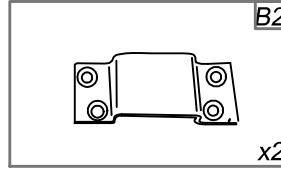
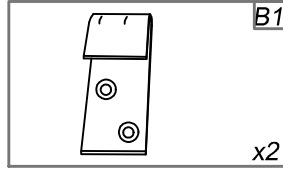
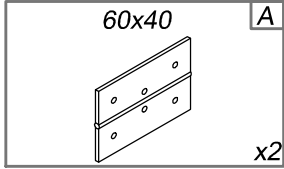

**PL** Elementy

**GB** Elements

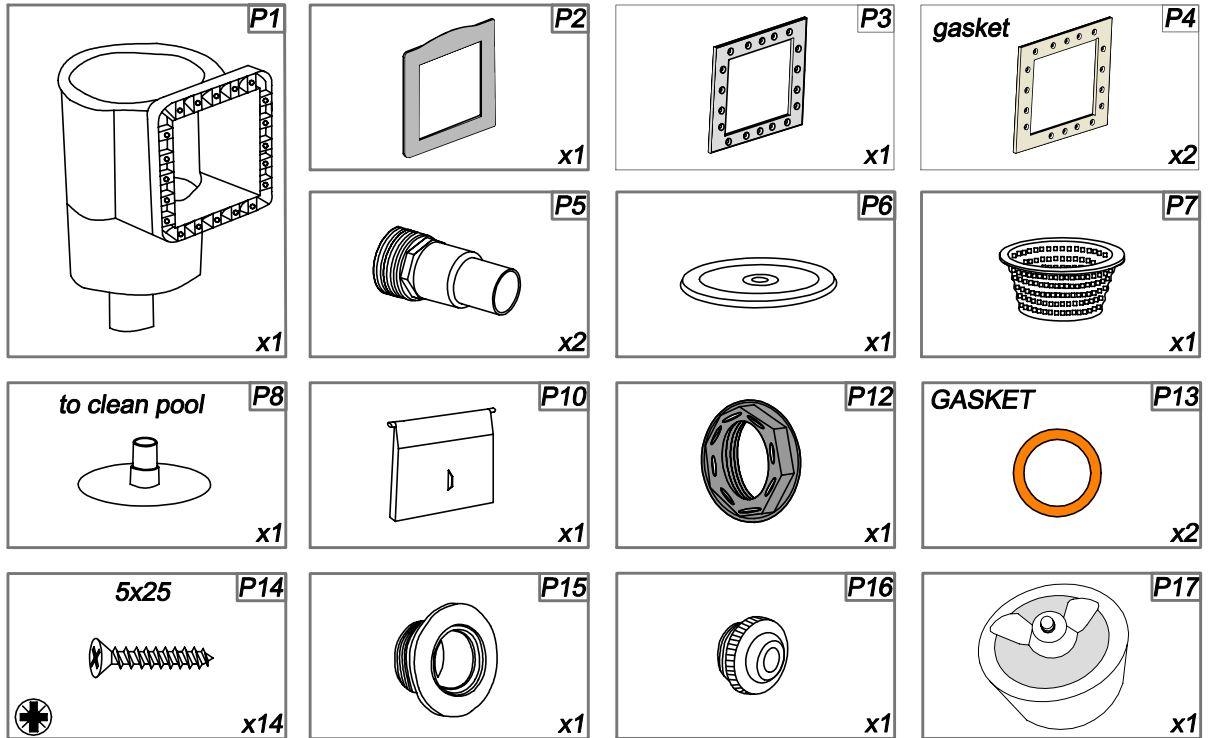

**UWAGA / NOTE**

**PL** Poszczególne elementy osprzętu w instrukcji mogą się nieznacznie różnić od faktycznie dostarczonych.

**GB** It is possible that some elements of equipment in the assembly instruction will not correspond exactly to those supplied

**UWAGA / NOTE**

**PL** Widok po zmontowaniu.

**GB** After installation.

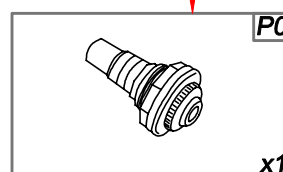
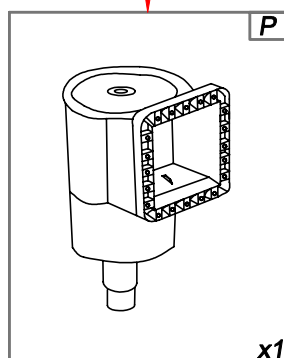

**PL** Zatyczka dyszy

**GB** Rubber plug



**ZATYCZKA DO DYSZY** - w celu przygotowania basenu do sezonu zimowego (w szczególności przy ryzyku zamarznięcia wody) zastosuj zatyczkę do dysz napływowych, odcinając dopływ wody do zestawu filtracyjnego. **Pozostaw dyszę w basenie, zamontuj zatyczkę.** Należy pamiętać również o odłączeniu zestawu filtracyjnego od źródła wody i dokładnym osuszeniu dysz od strony zewnętrznej. Zaleca się także, aby z pompy jak i dołączonego filtra piaskowego na okres zimy (w miejscach gdzie występują mrozy) usunąć pozostałości wody, w innym przypadku zamarzająca woda może dokonać zniszczenia całości zestawu.

**Rubber plug** - in order to prepare the pool for the winter season (especially if there is a risk of freezing) put a plug into the inlet to shut off the access of water to the filtration system. **Inlet must remain in the pool.**

**Fix the plug under water.** Remember to disconnect the filtration set from the pool and dry the inlet (the part of inlet which is outside of the pool). For the winter season, it is recommended to get rid of water remaining in pump and sand filter, otherwise freezing water can cause devastation of the whole set.

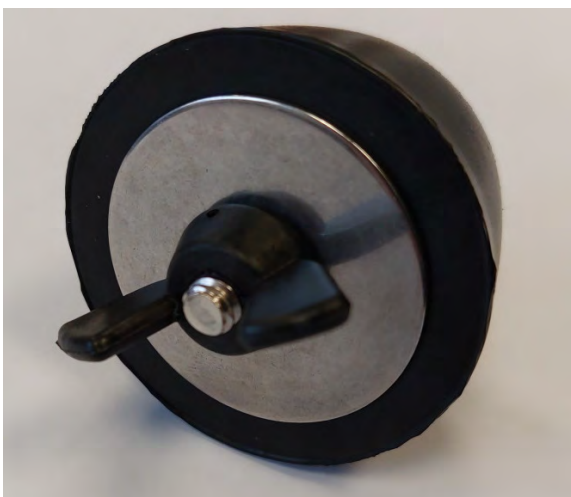

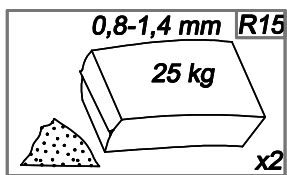
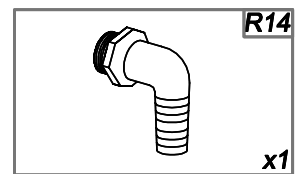
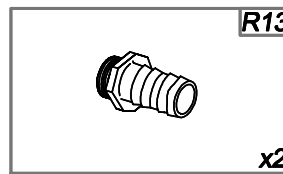
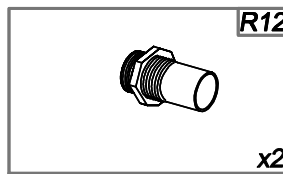
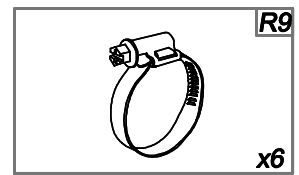
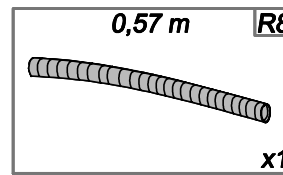
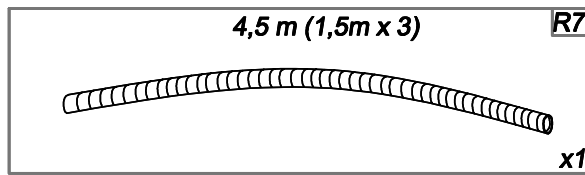
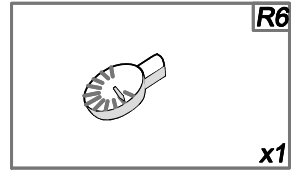
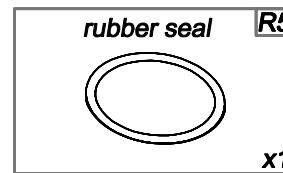
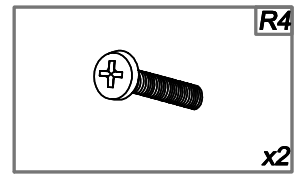
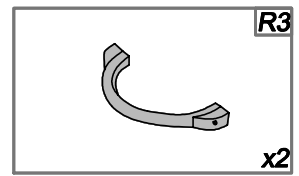
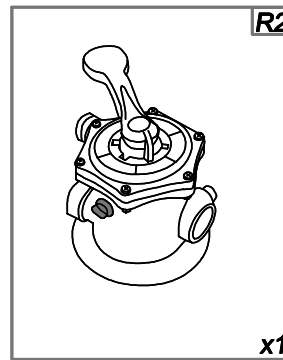
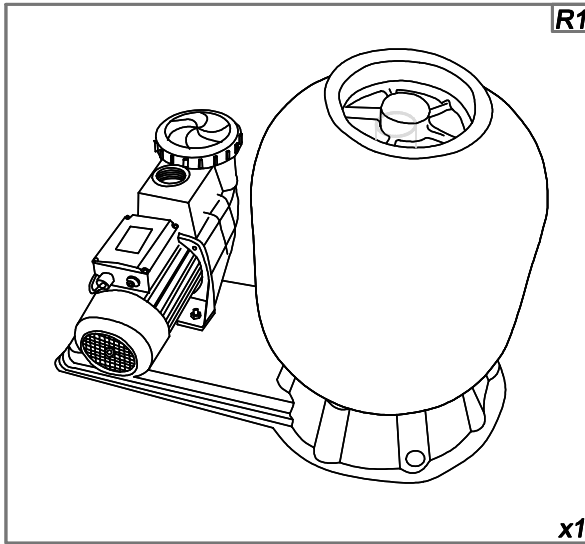

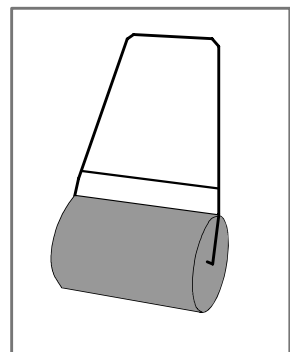
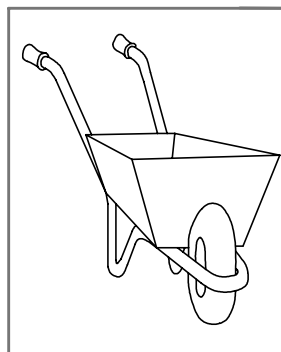
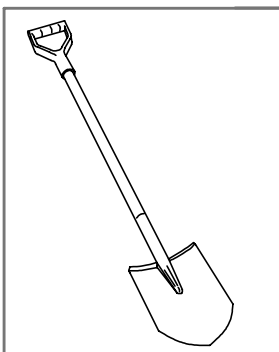
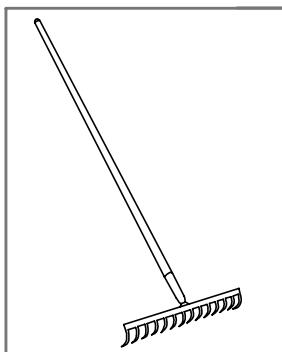
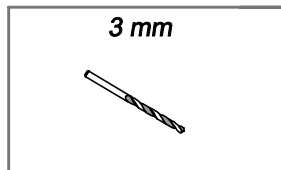
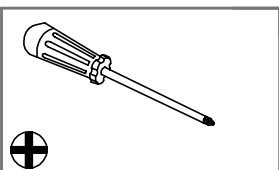
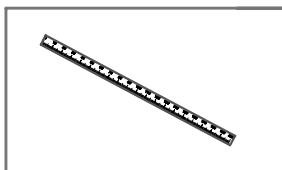
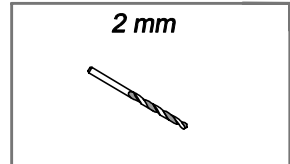
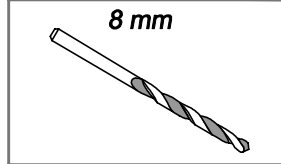
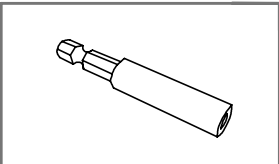
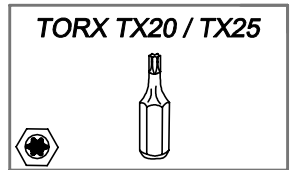
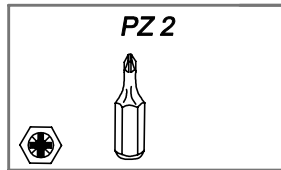
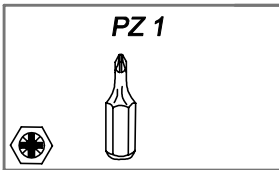
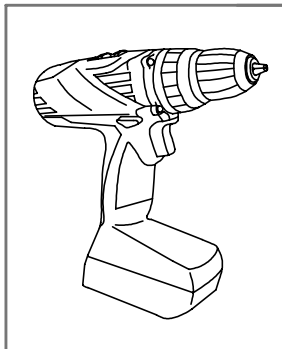
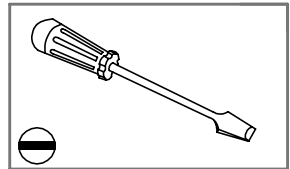
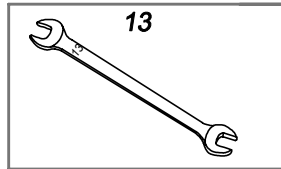
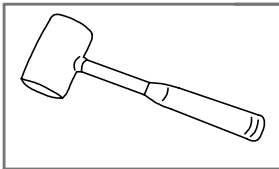
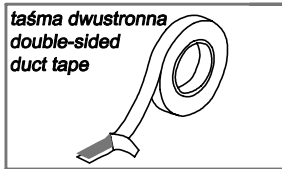
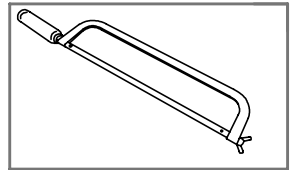
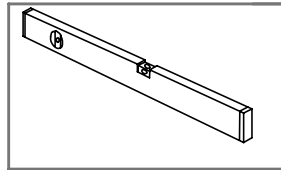
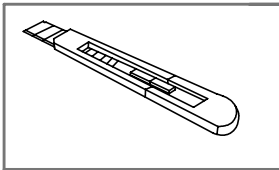
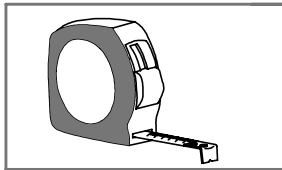
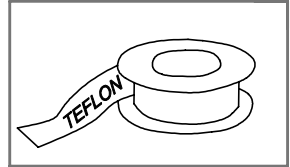
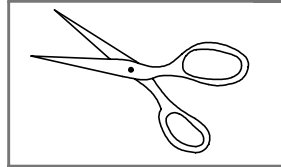
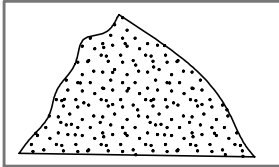
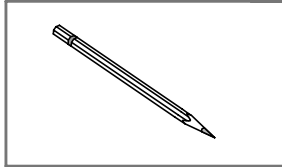
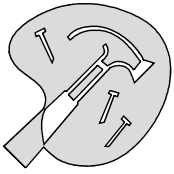

PL Podłoże

GB Ground

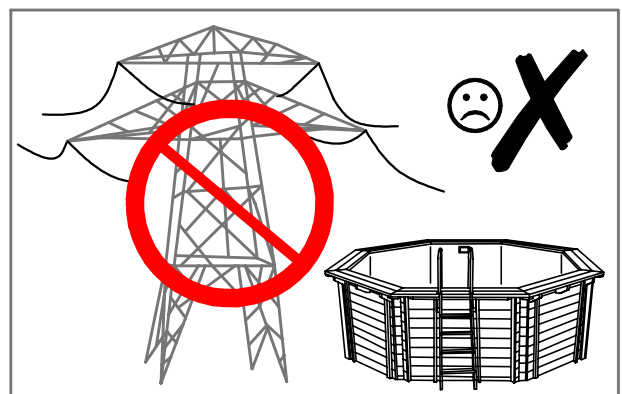
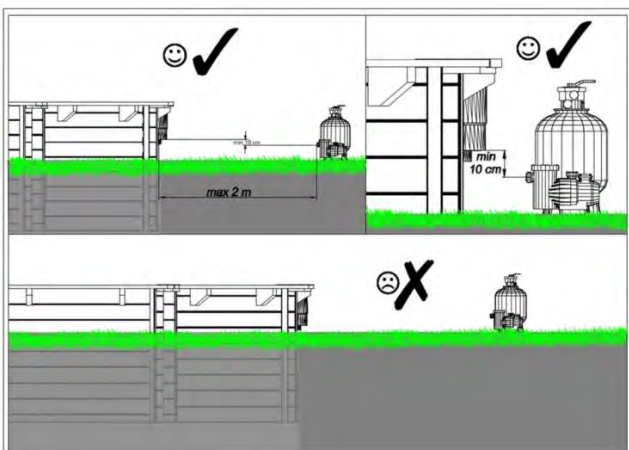
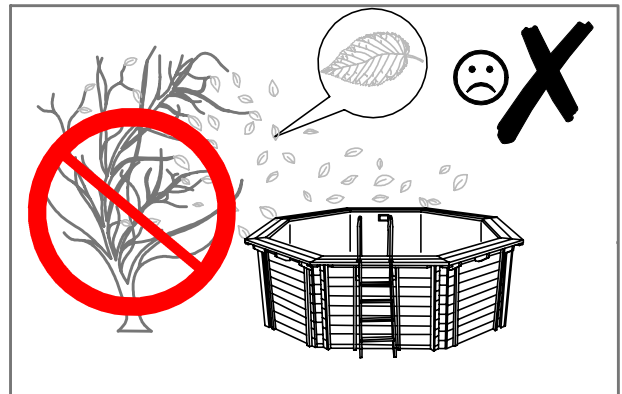
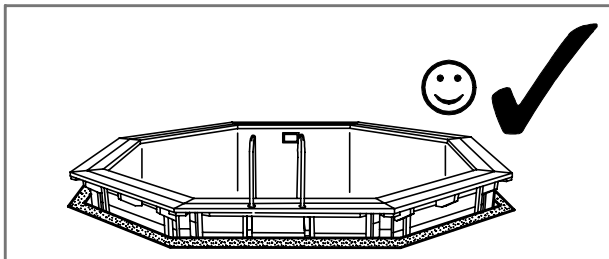
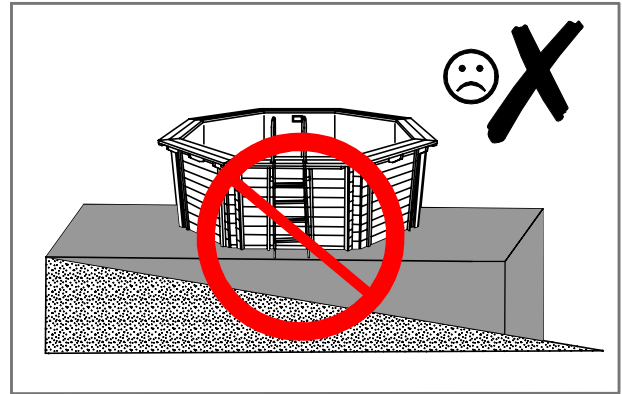
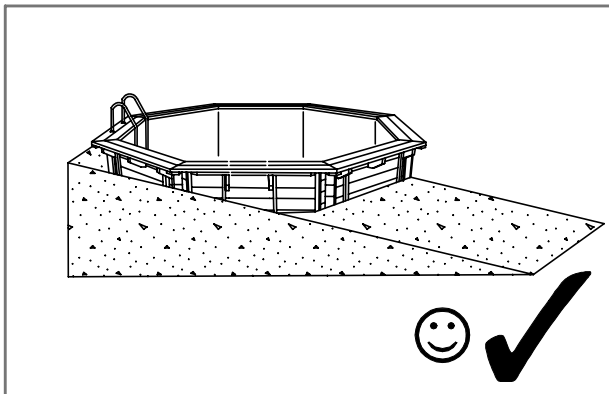
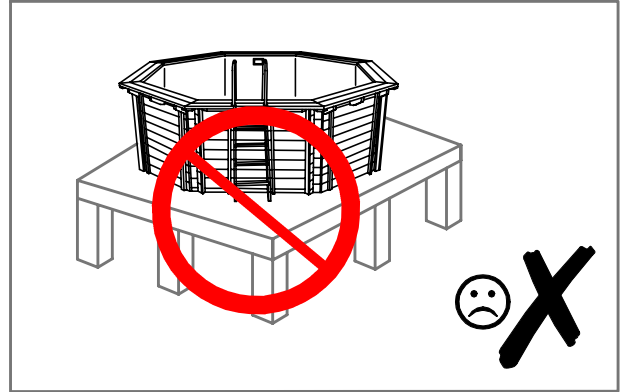
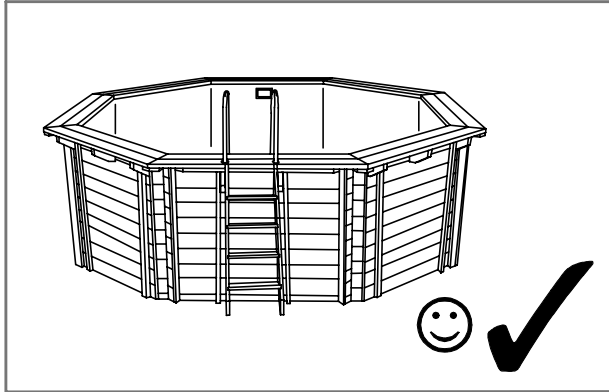



- 1 FUNDAMENT BASENU / FOUNDATION
- 2 RURA DRENARSKA / DRAINAGE PIPE
- 3 PEČHERZYKOWA FOLIA FUNDAMENTOWA / FOUNDATION BUBBLE WRAP
- 4 ŻWIR / GRAVIER / GRAVEL
- 5 GEOWŁÓKNINA OGRODOWA / GEOTEXTILE
- 6 GRUNT / GROUND

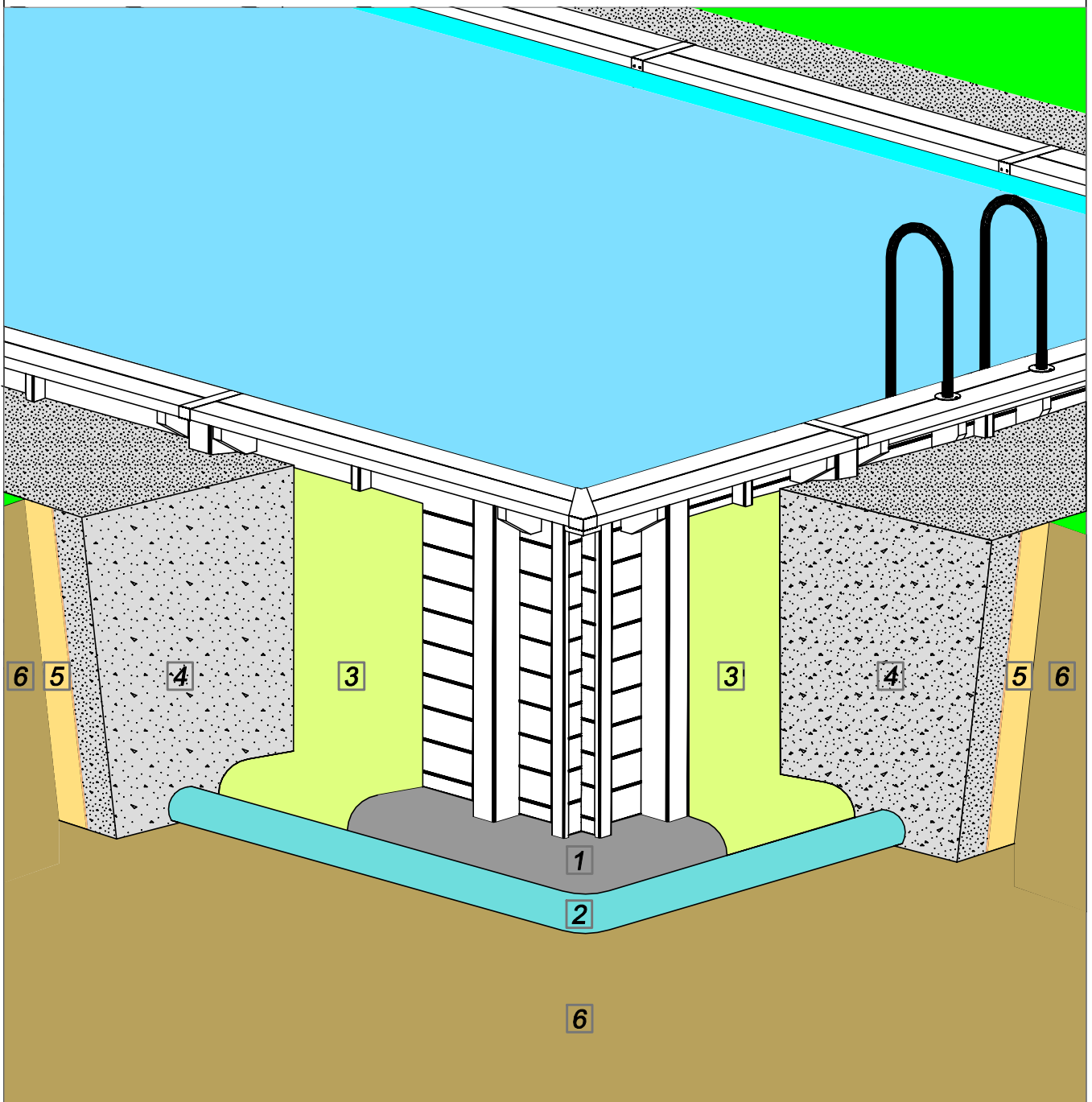

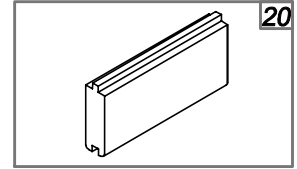
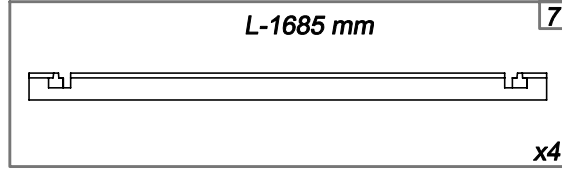
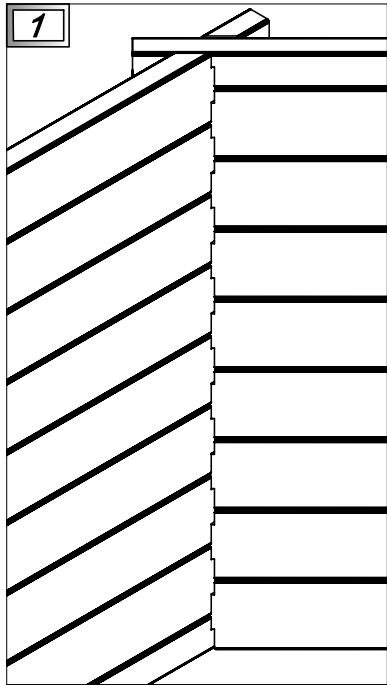

/

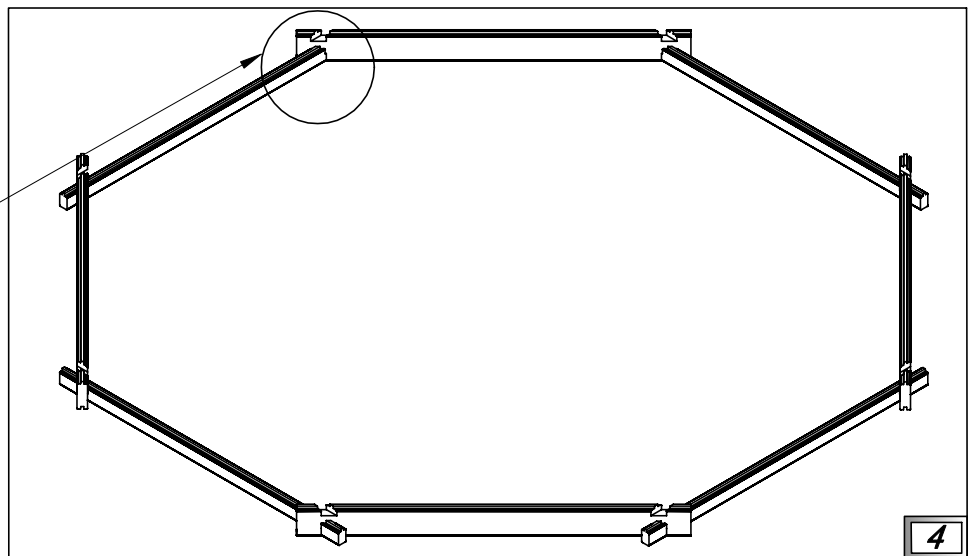
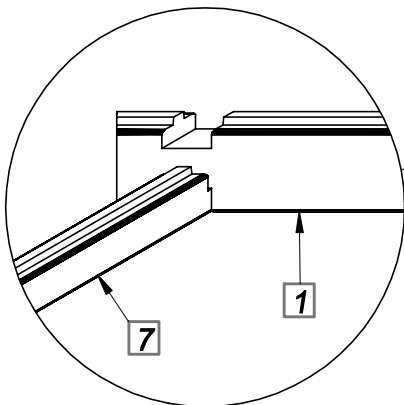
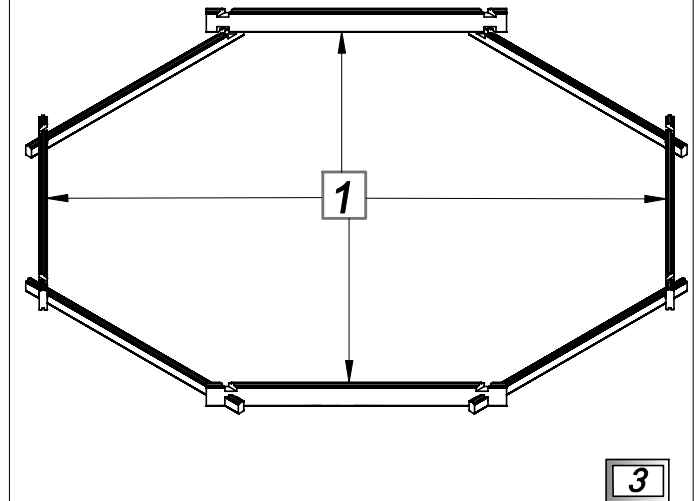
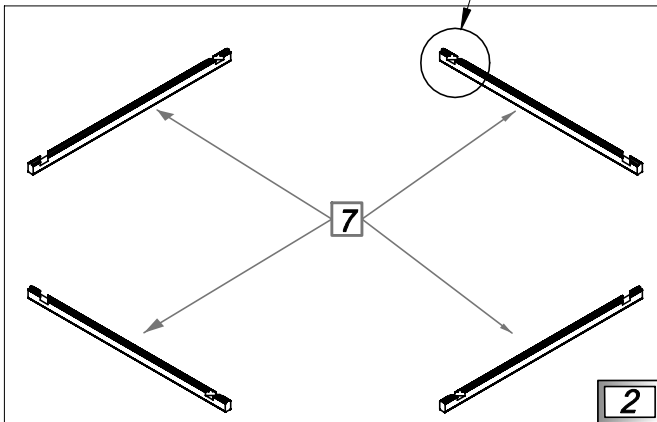
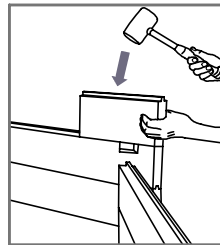
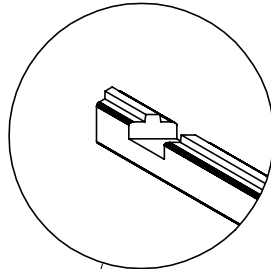
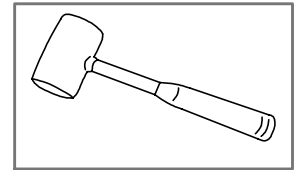
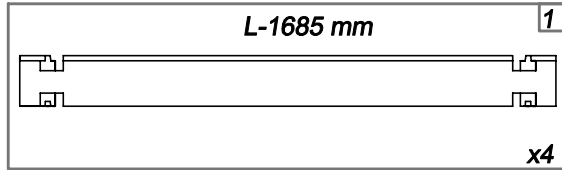

PL Podłoże

GB Ground

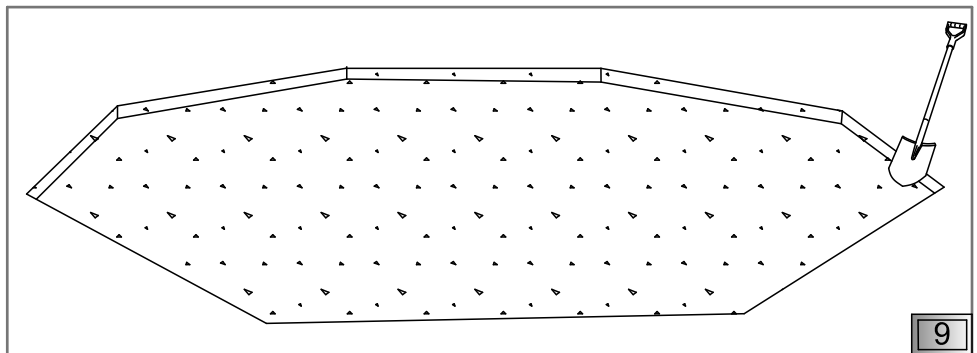
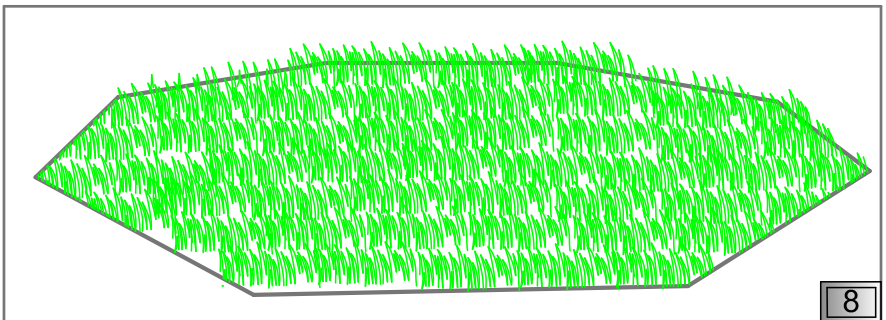
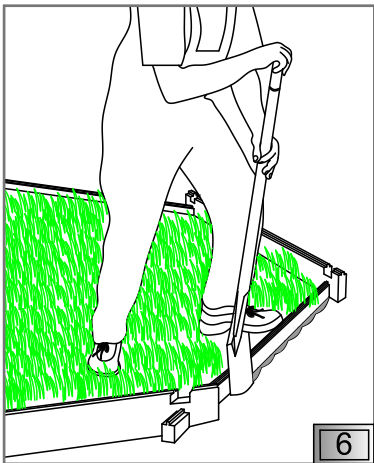
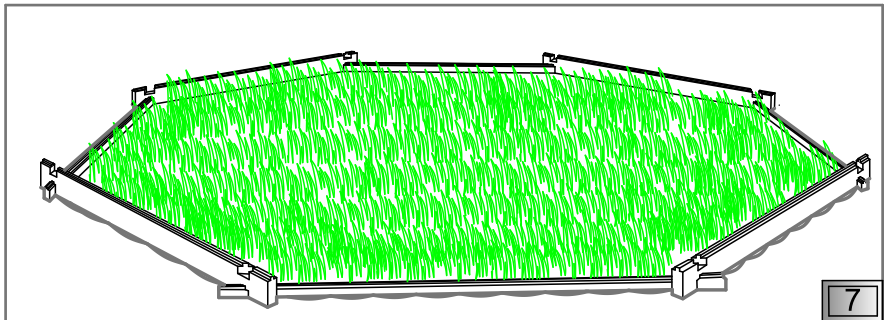
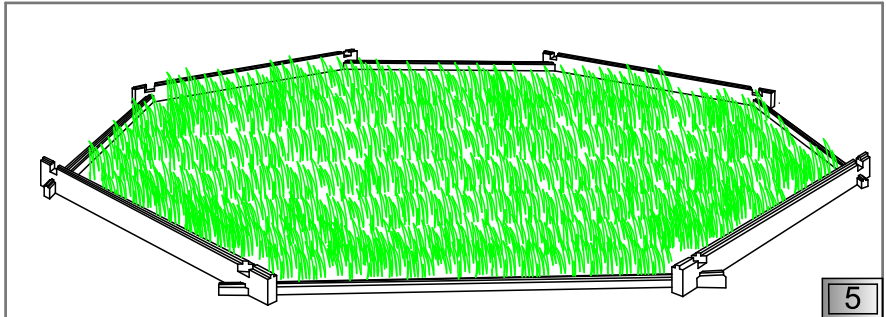
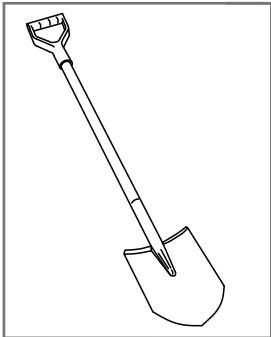

PL Podłoże

GB Ground

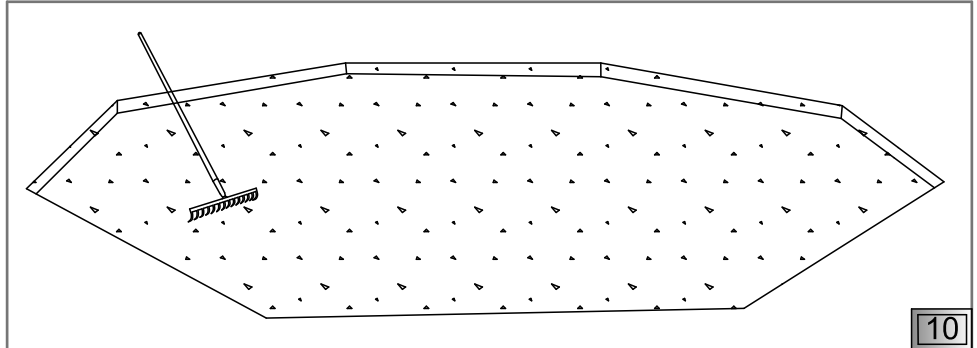
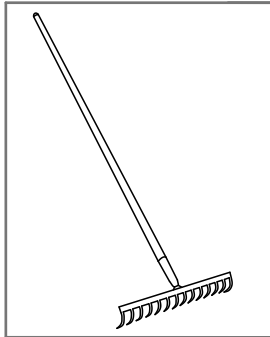

10

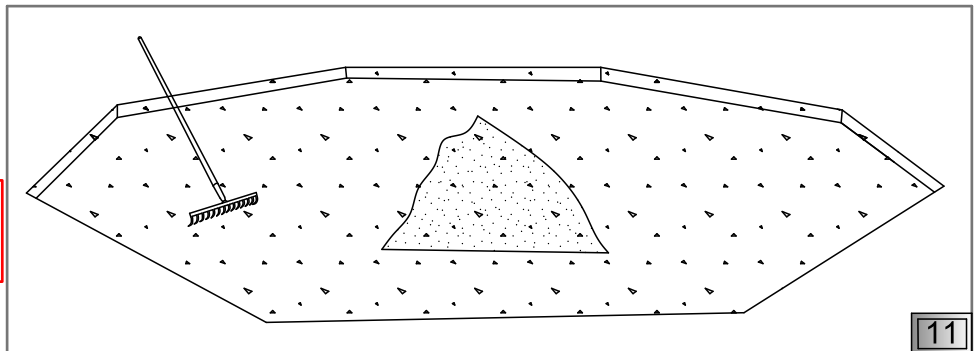
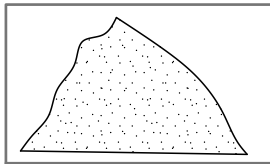

11

PL Piasek - warstwa 2 cm.

GB Sand- layer 2 cm.

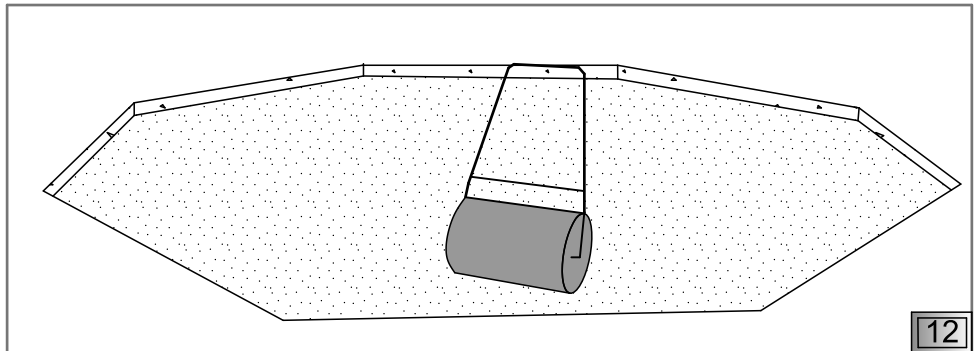
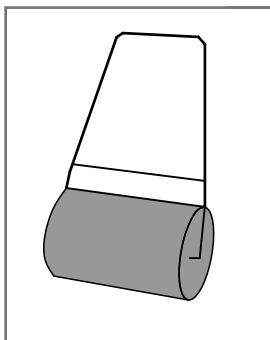

12

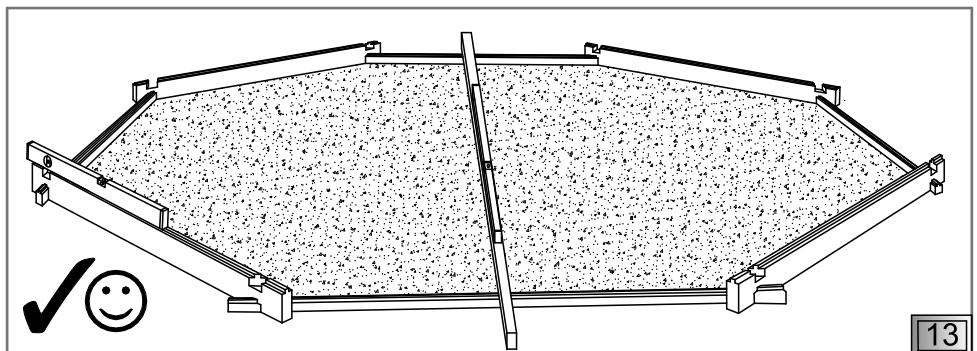
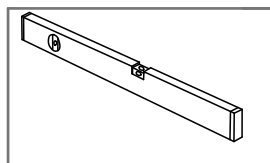

13

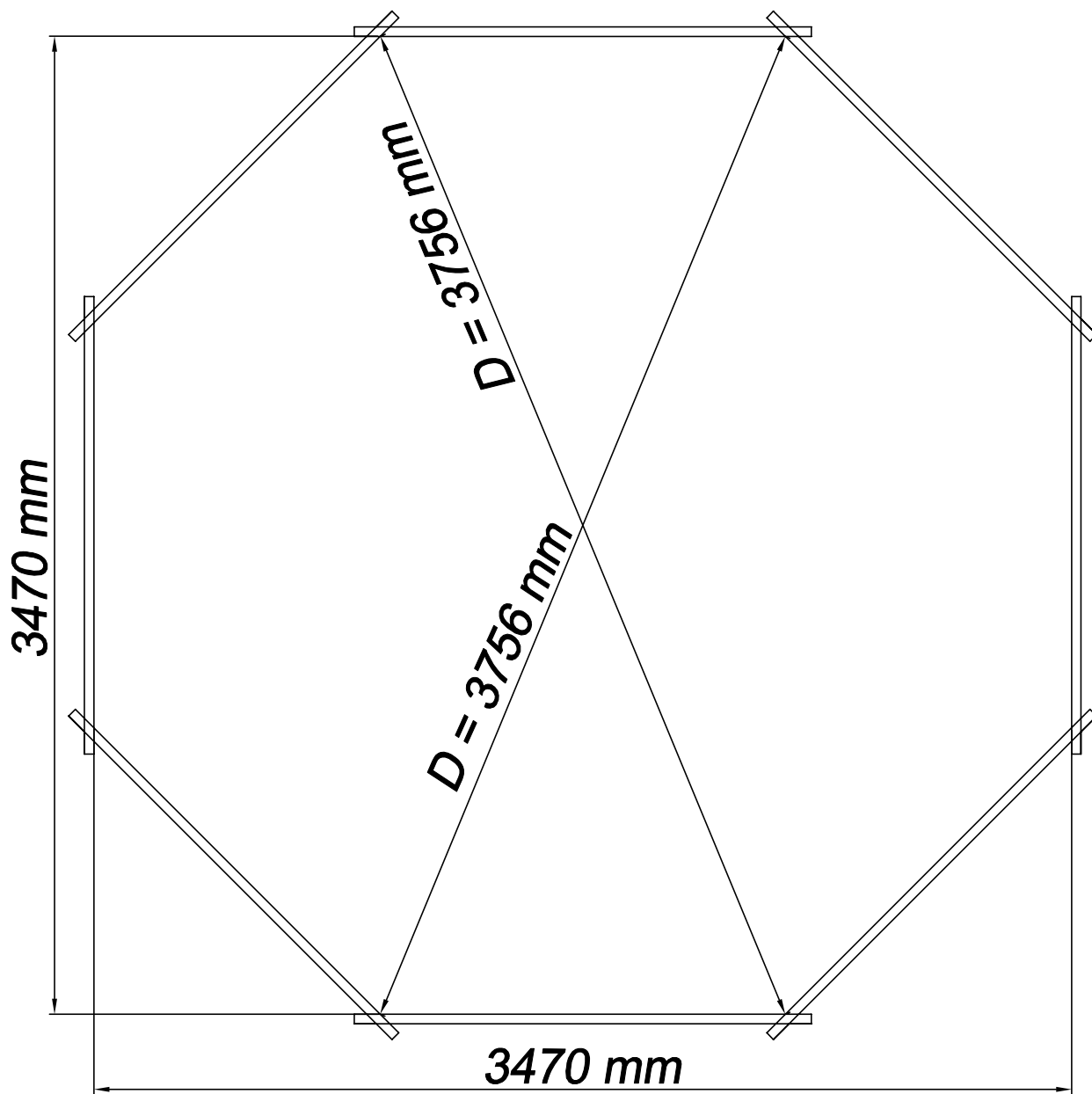
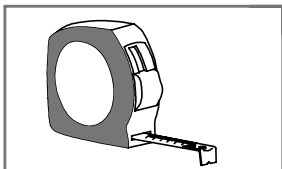



II-III

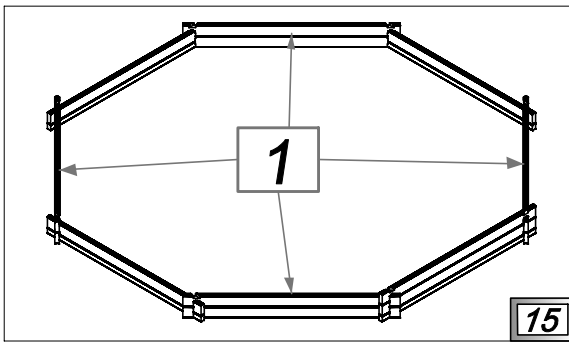
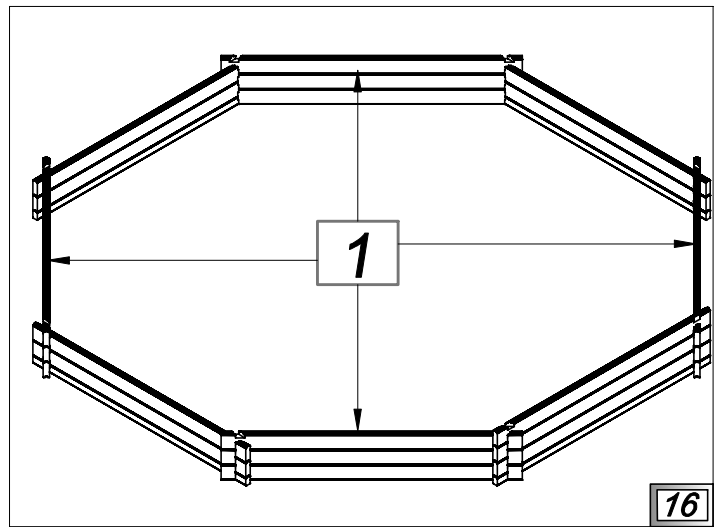
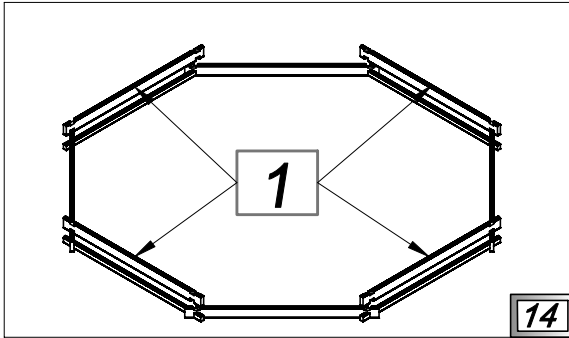
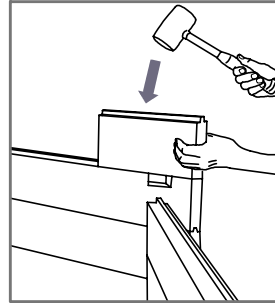
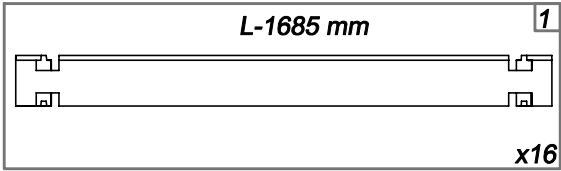

IV

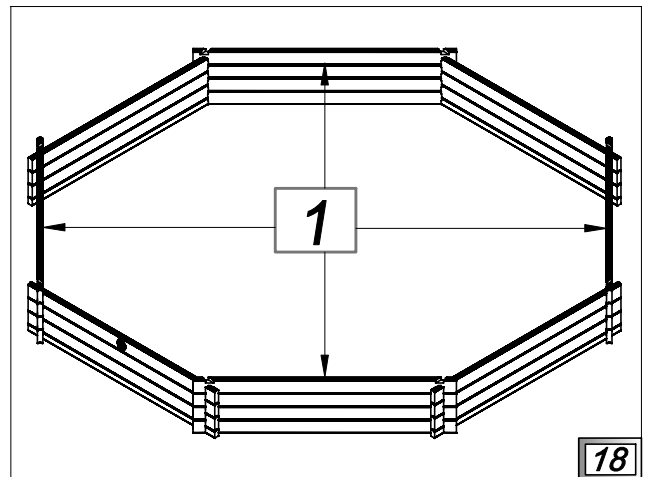
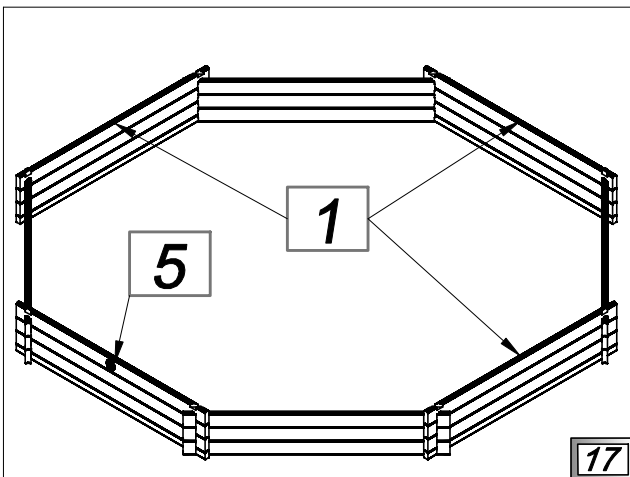
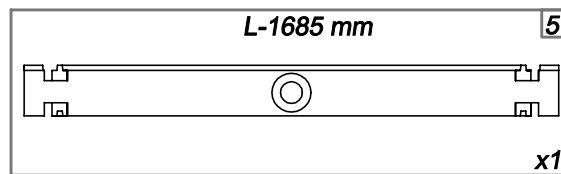
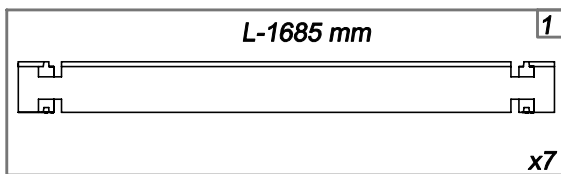



V-VII

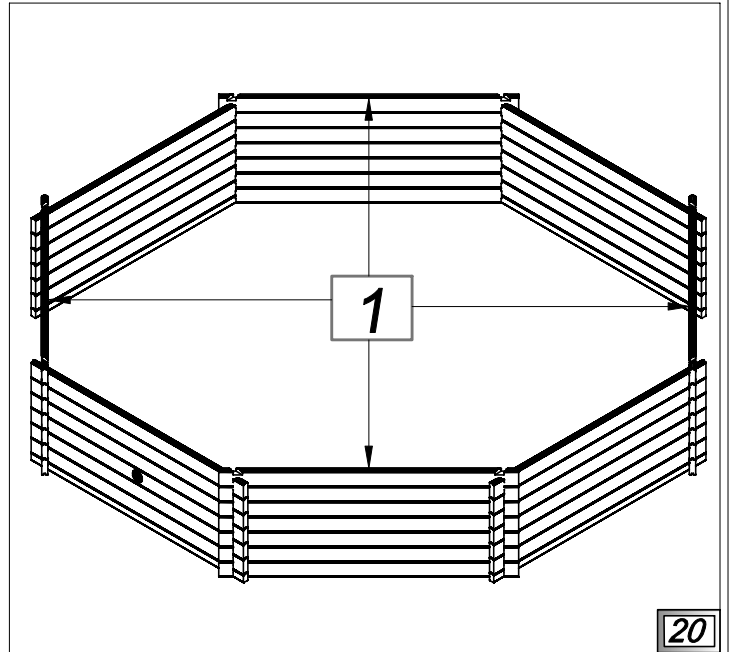
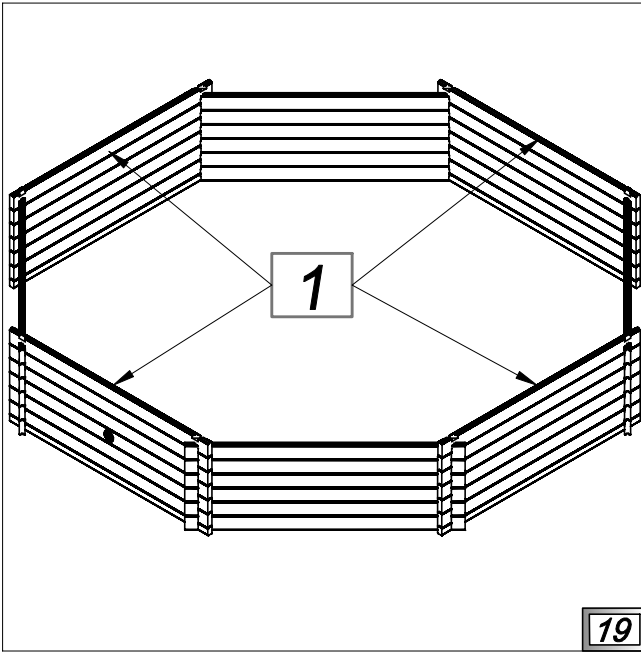
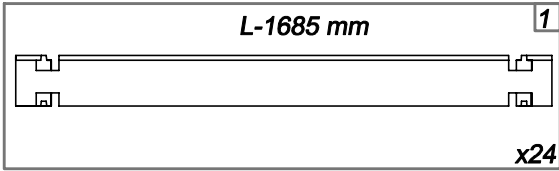

VIII

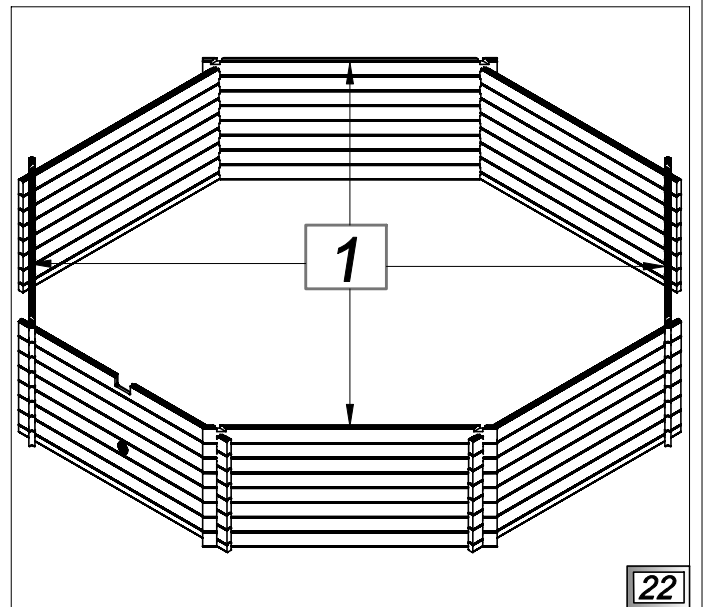
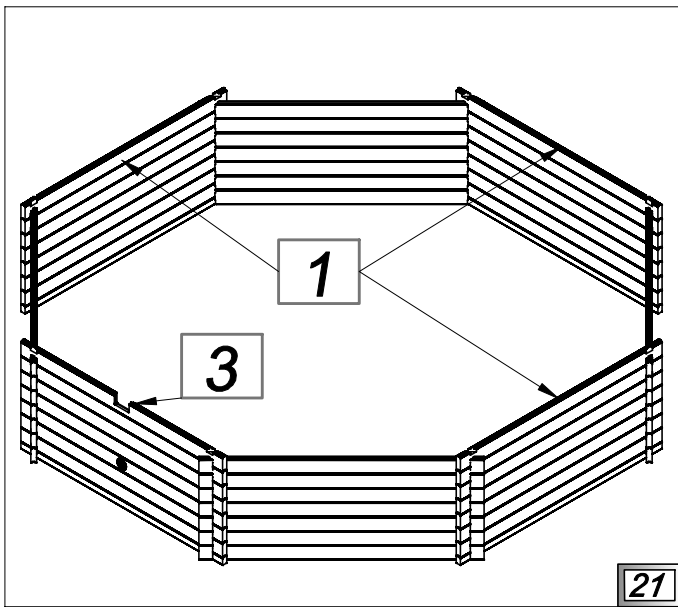
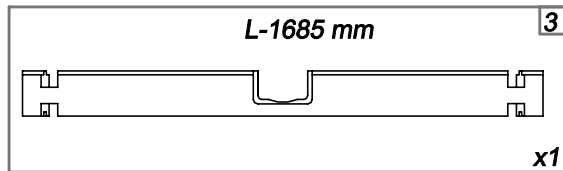
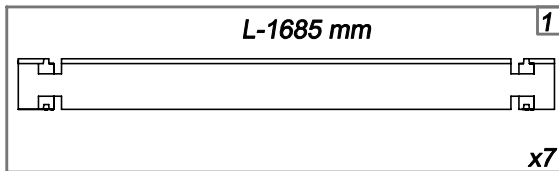

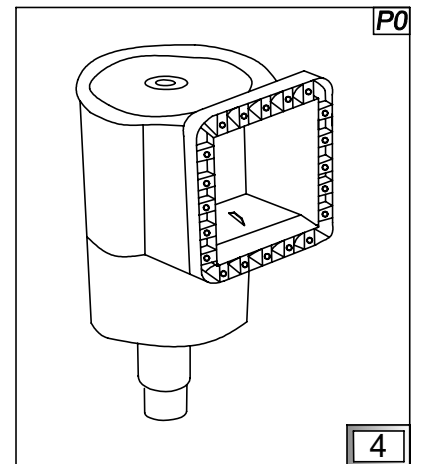
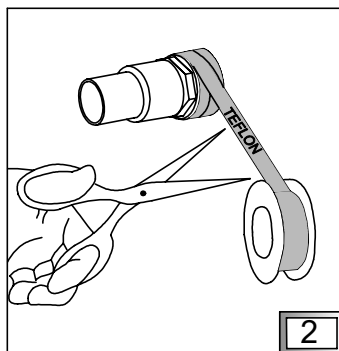
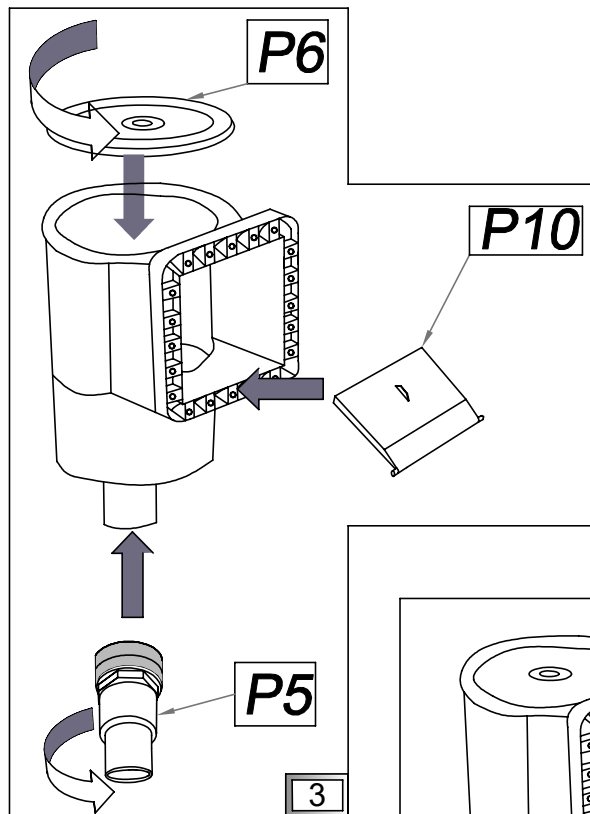
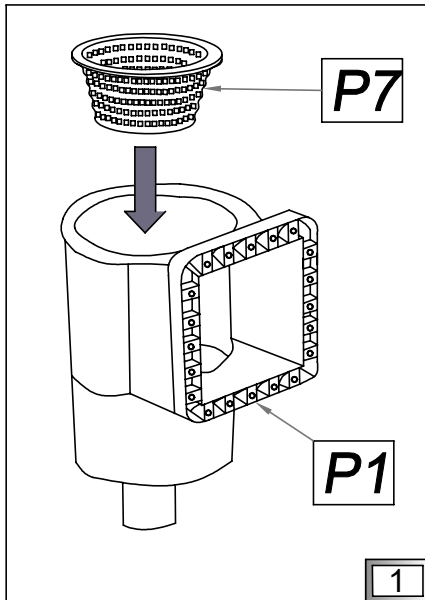
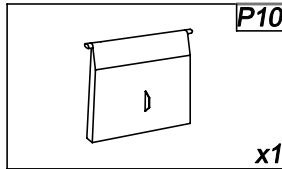
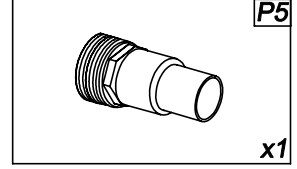
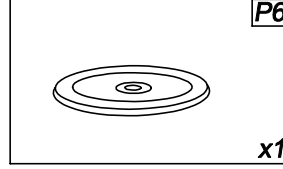
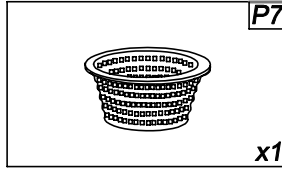
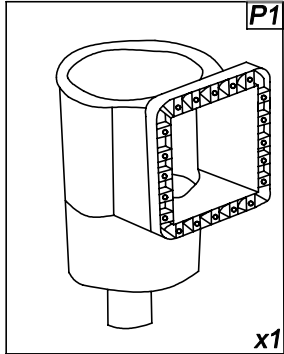

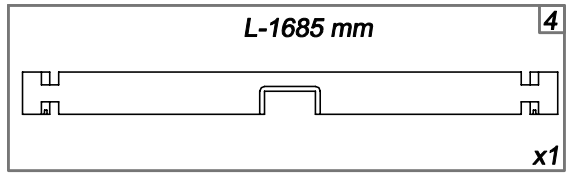
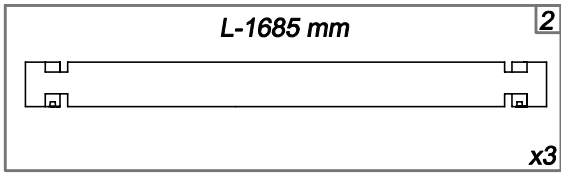

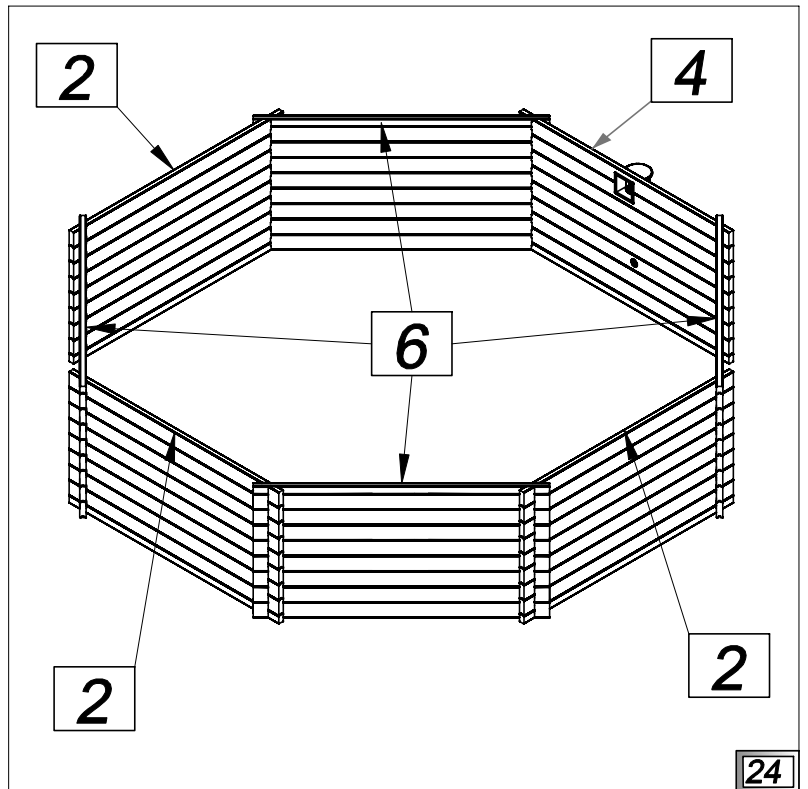
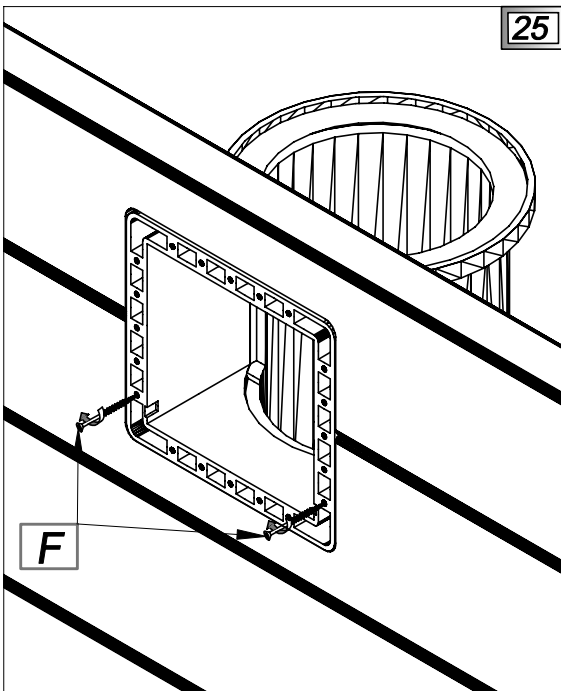
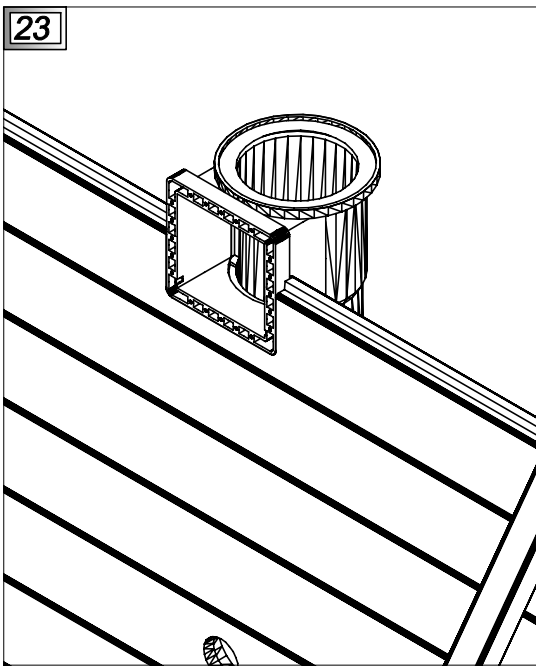
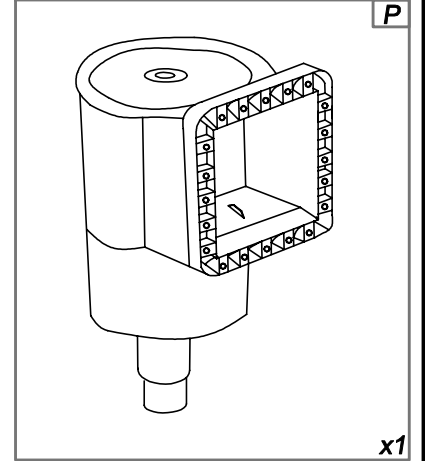
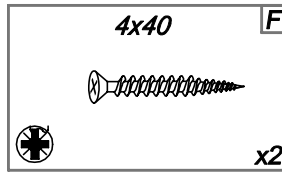
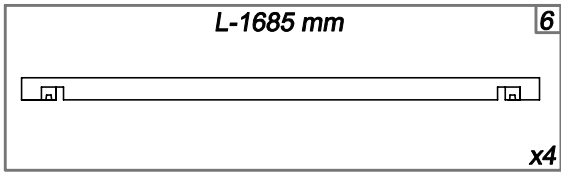

IX

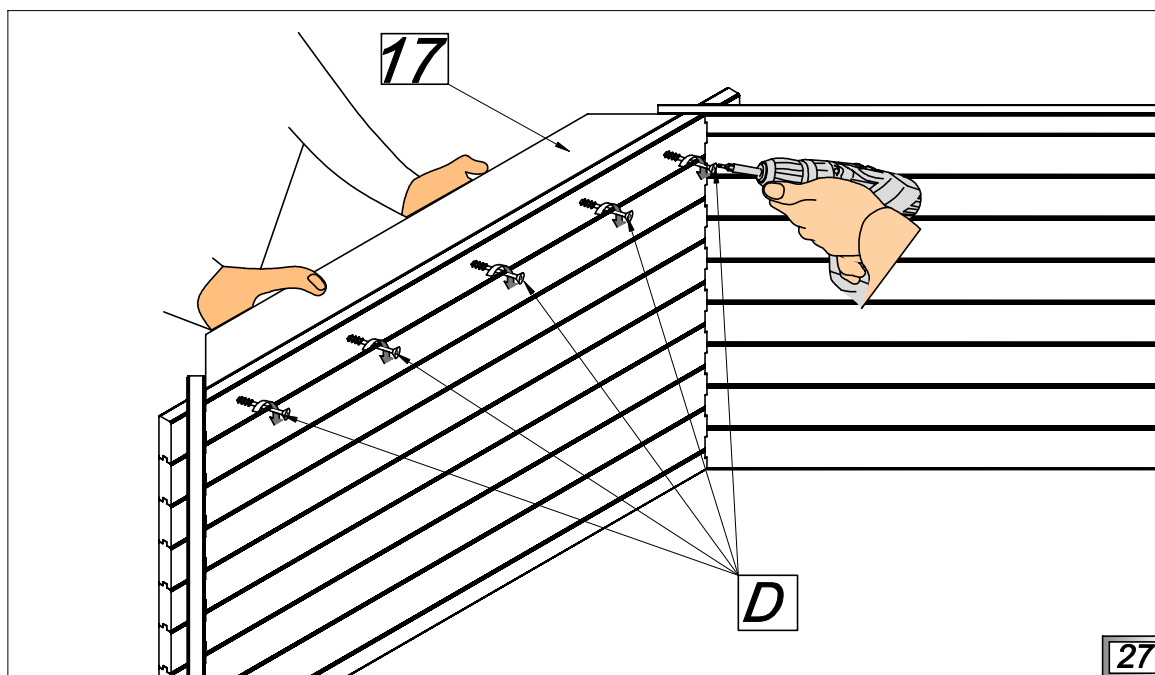
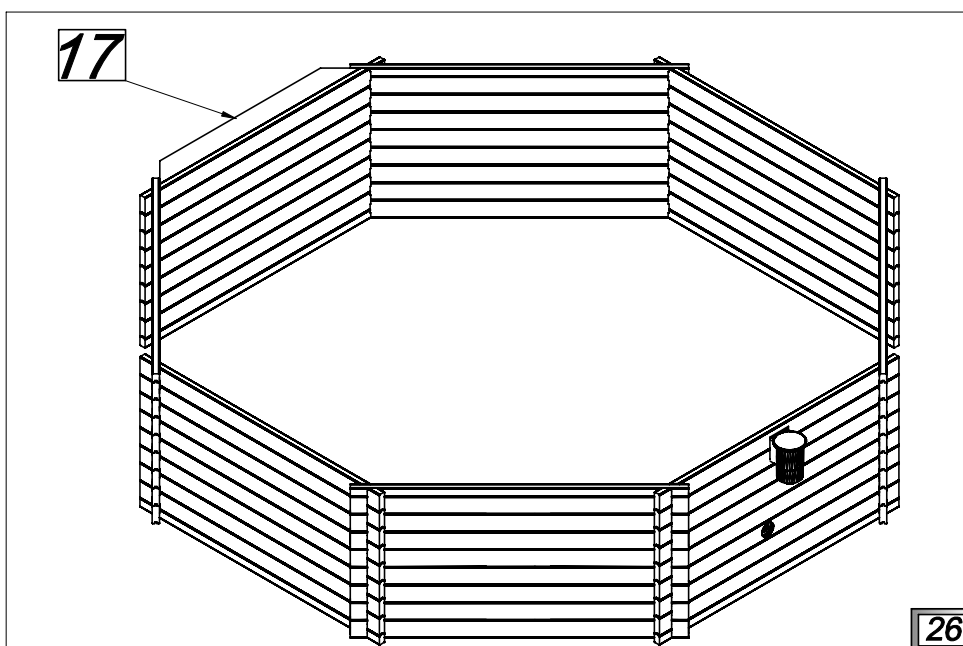
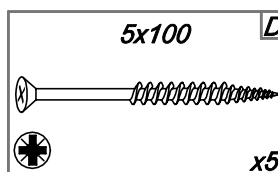
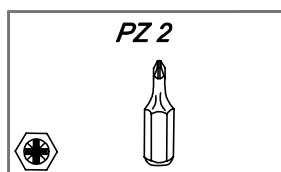
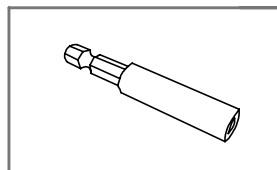
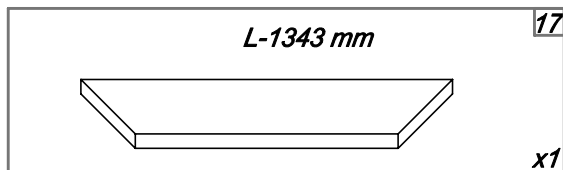
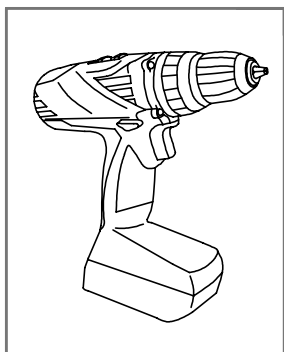

24

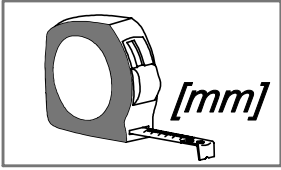



18 

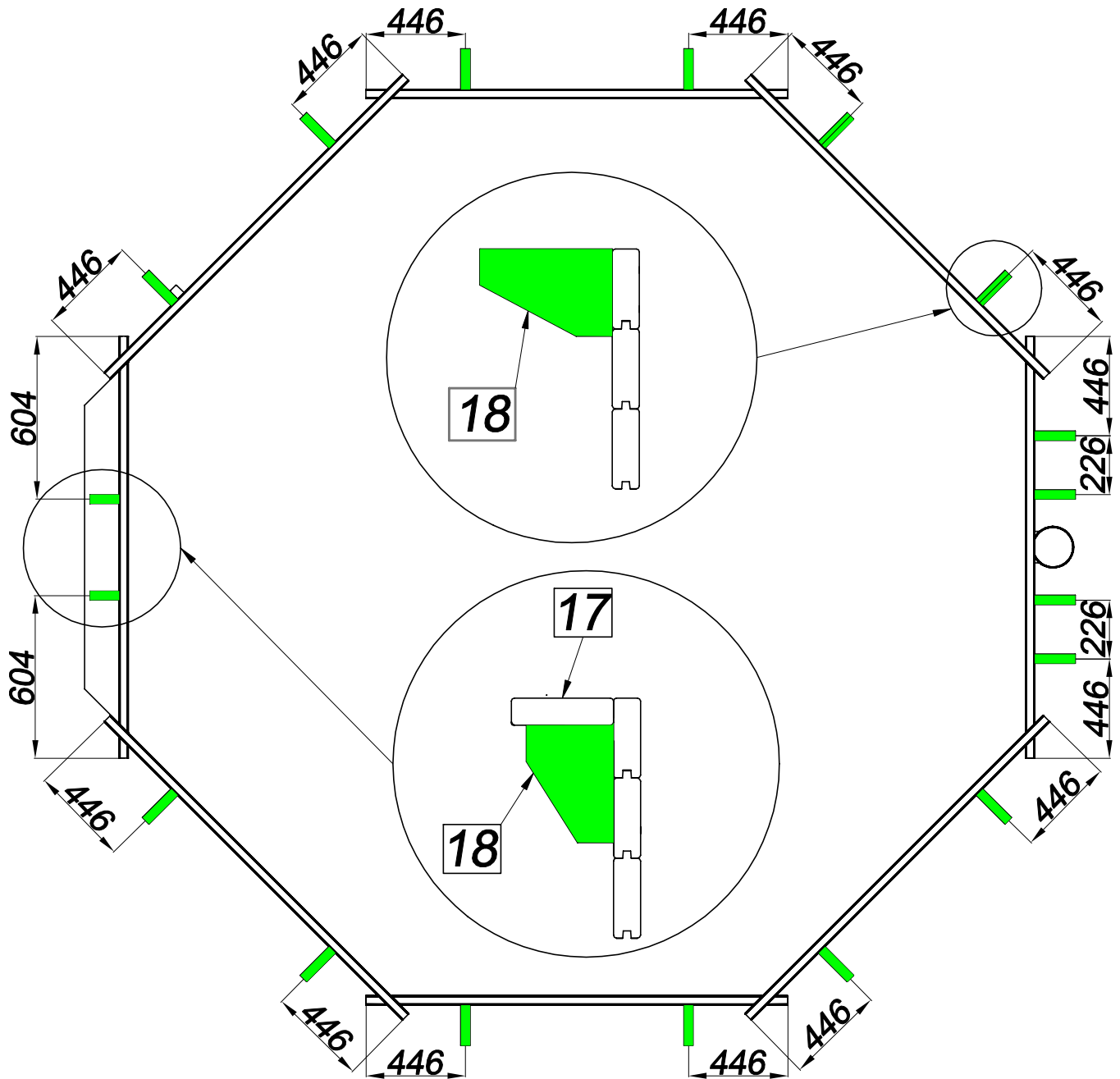

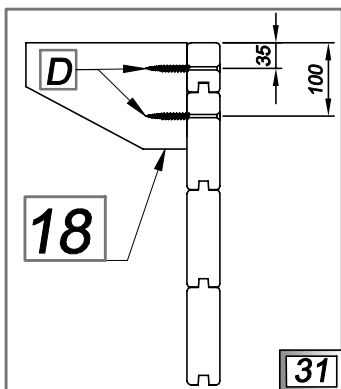
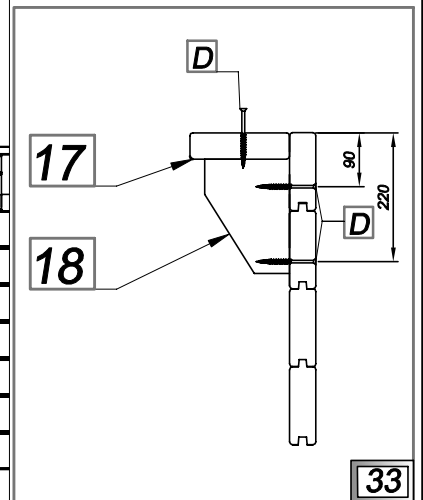
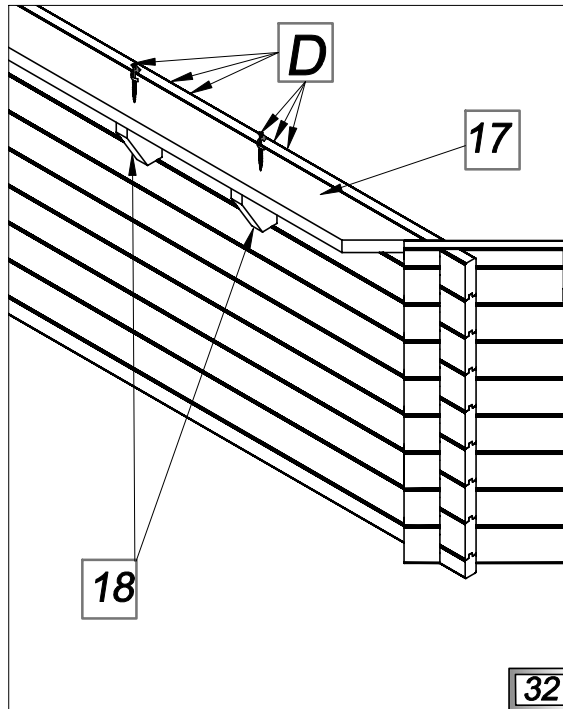
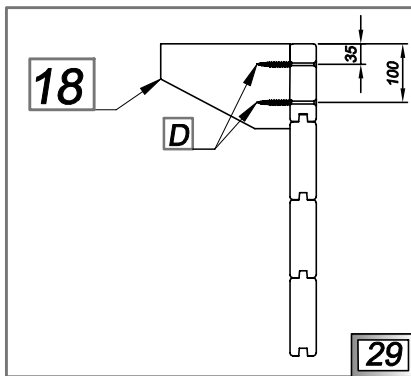
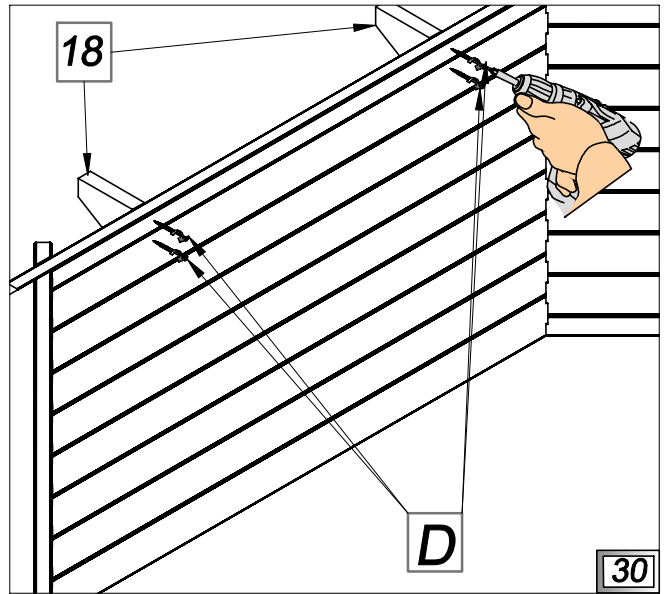
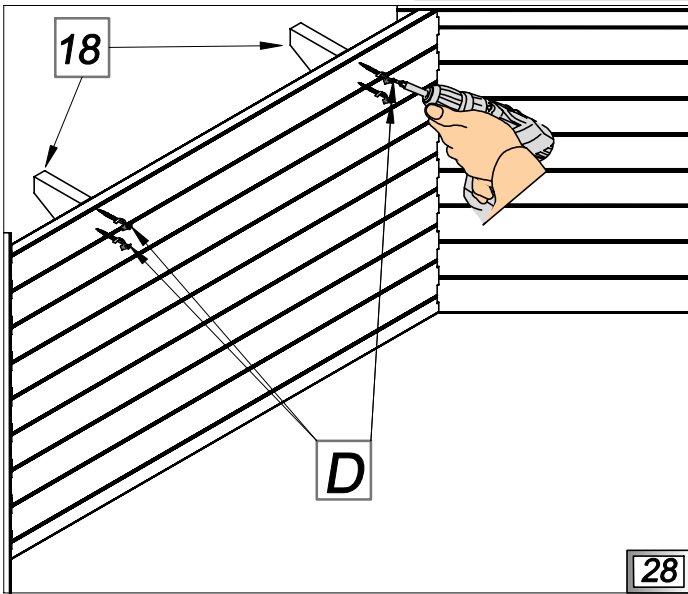
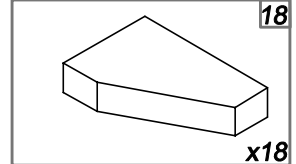
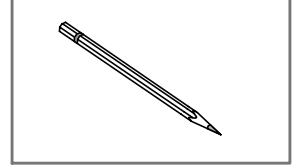
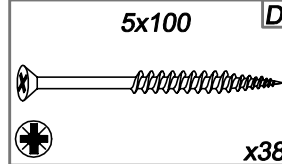
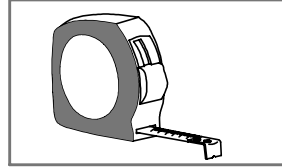
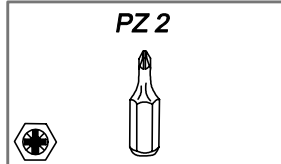
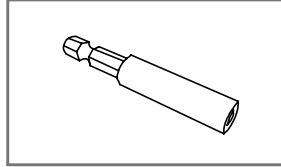
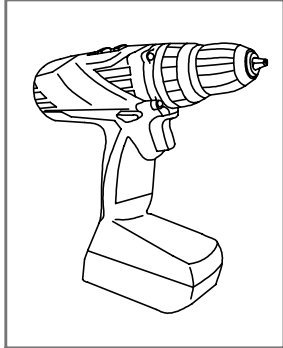

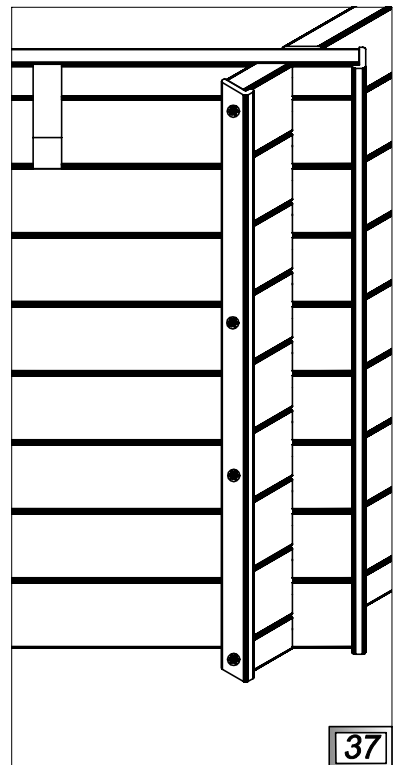
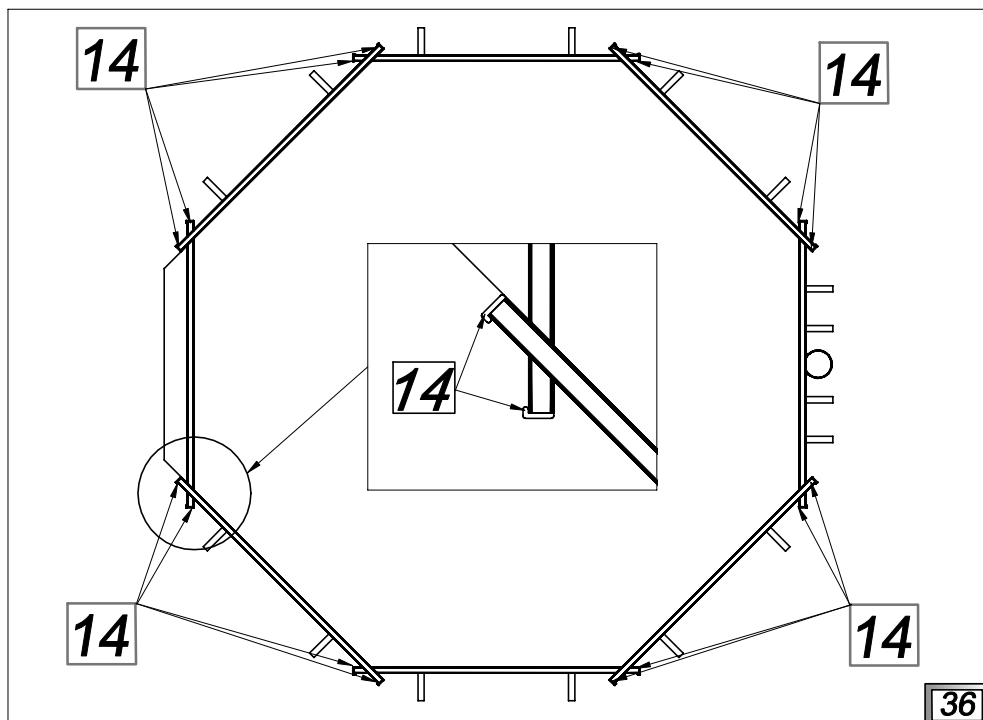
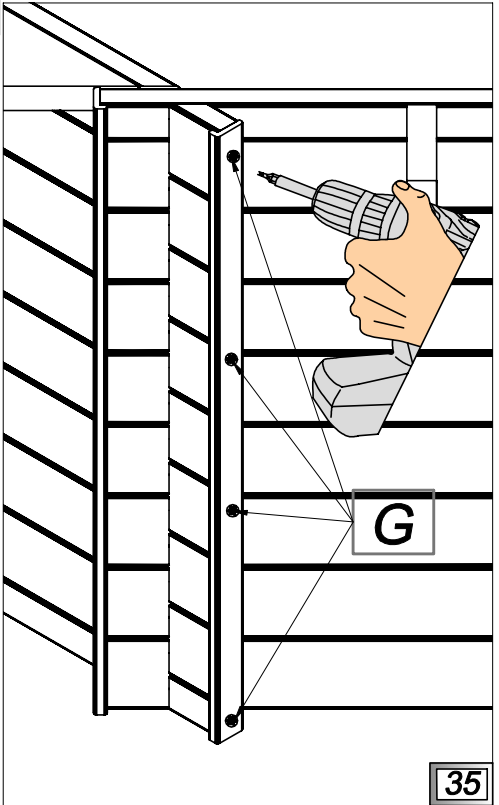
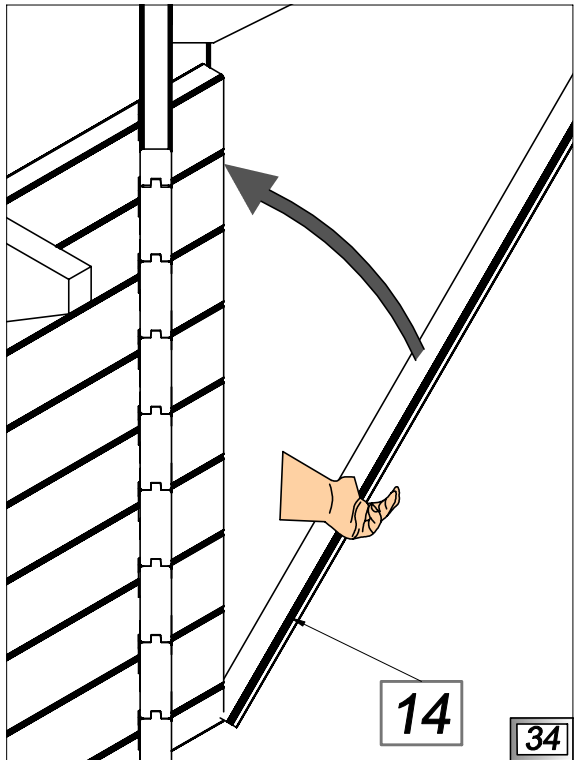
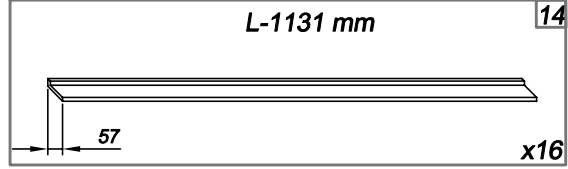
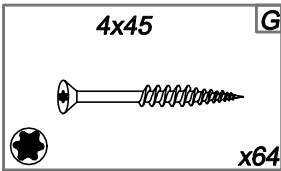
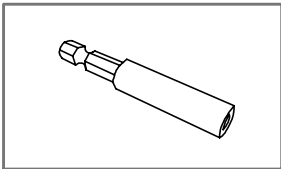
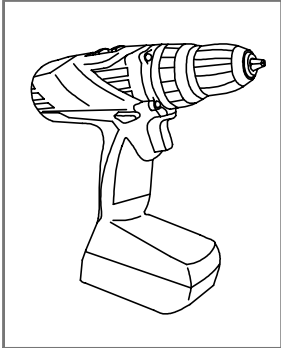

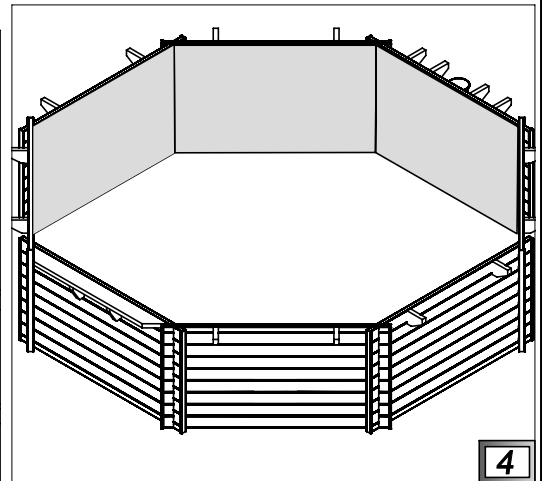
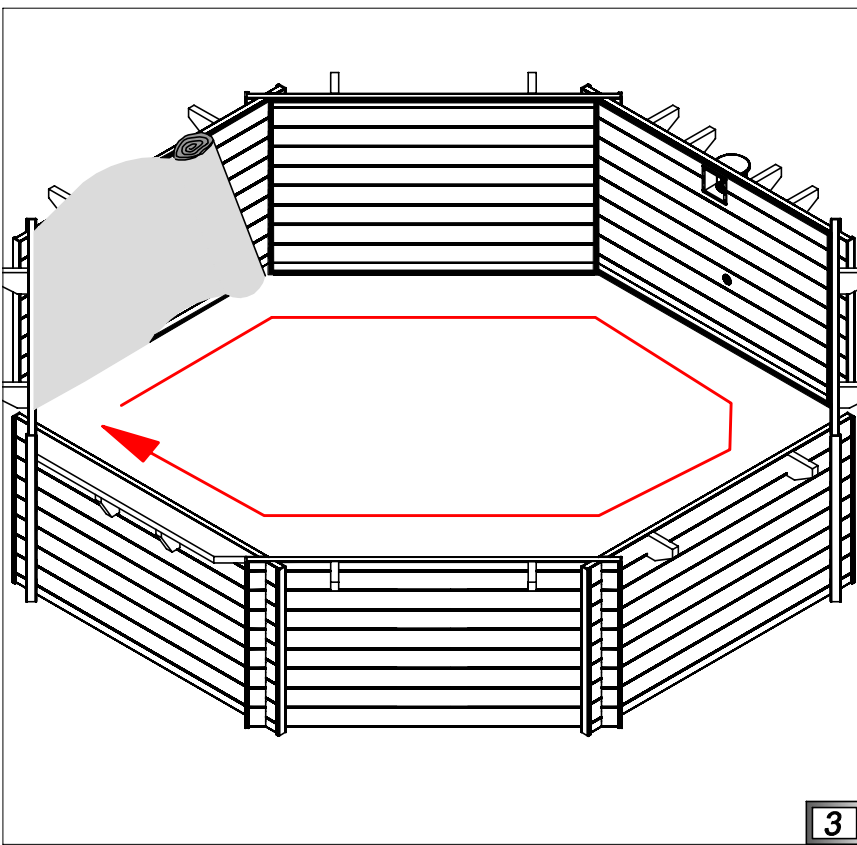
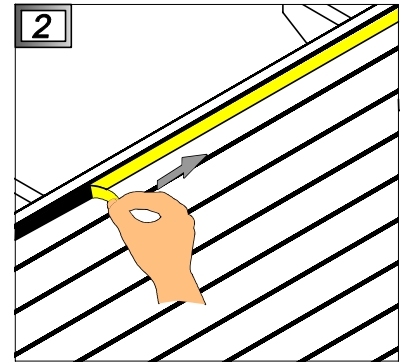
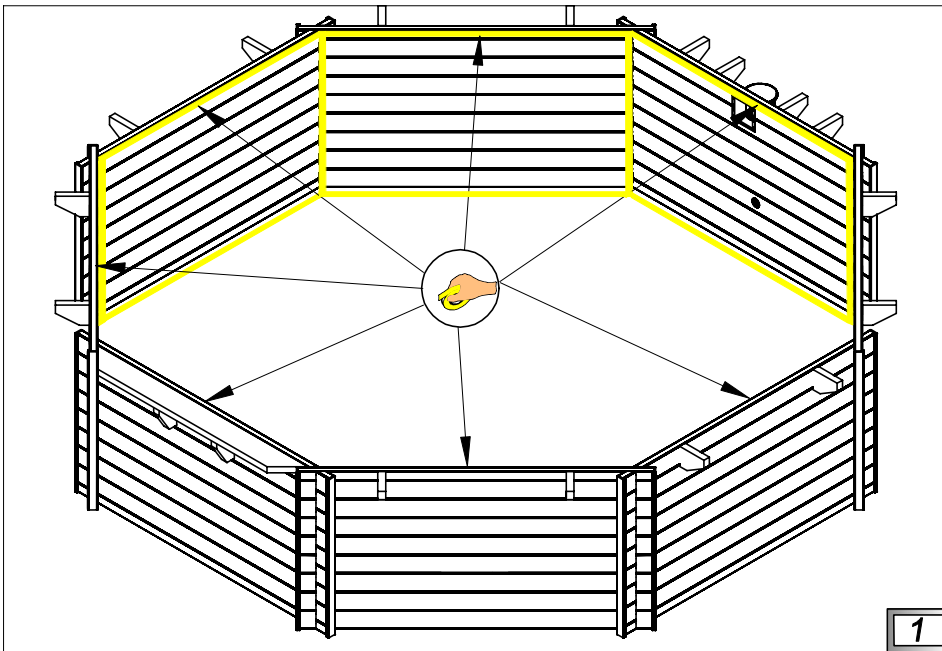
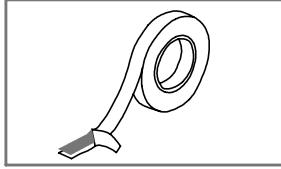
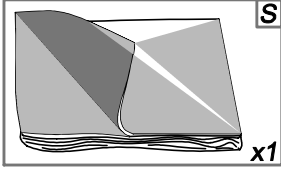

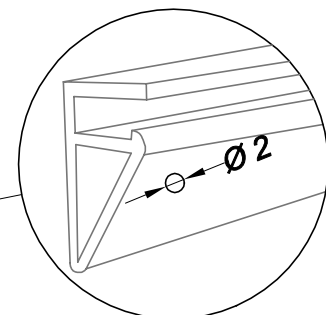
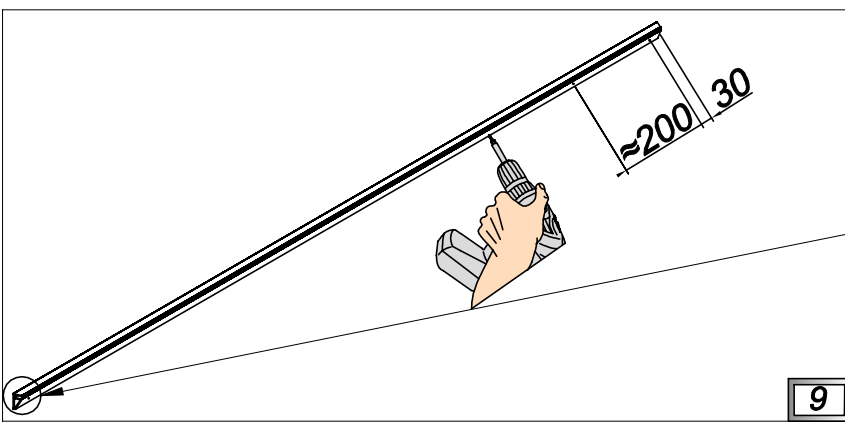
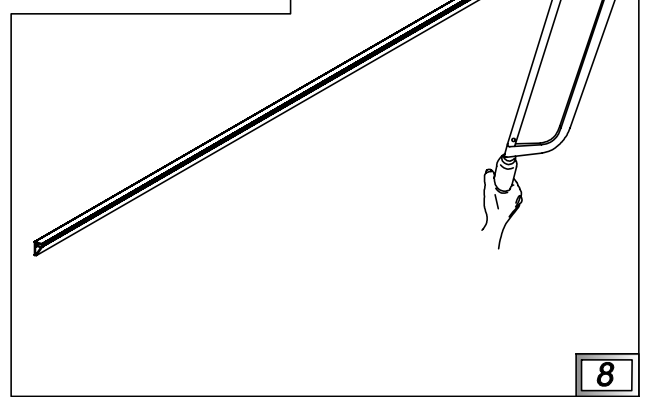
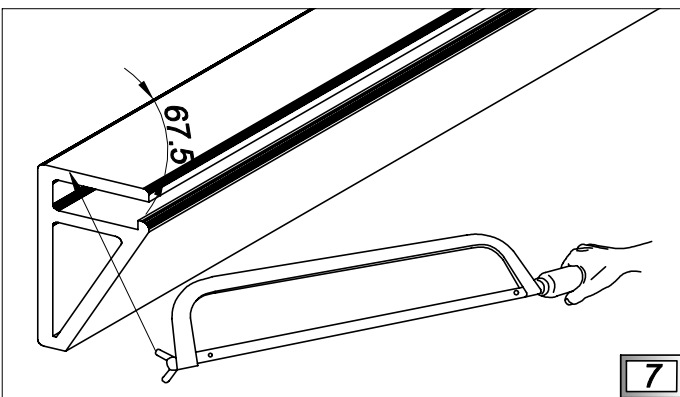
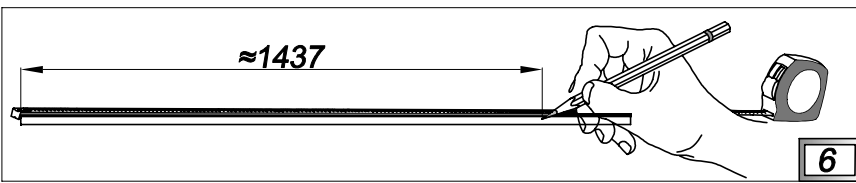
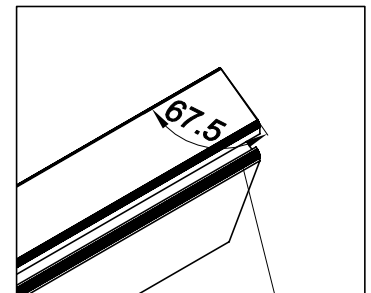
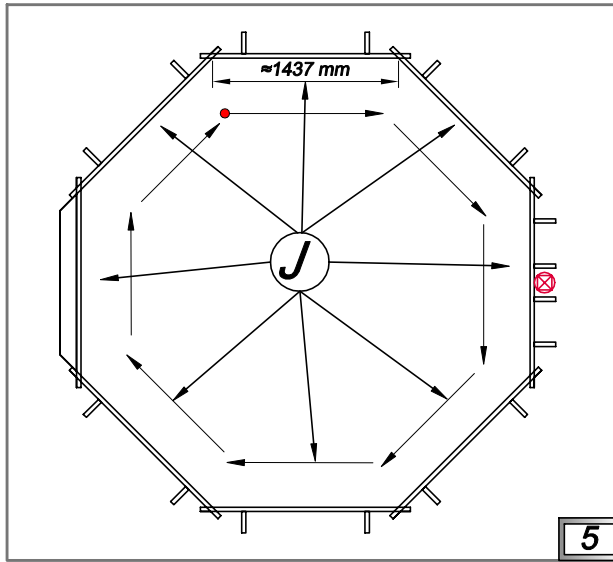
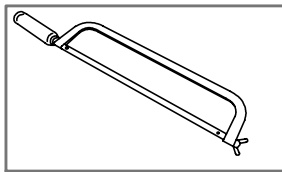
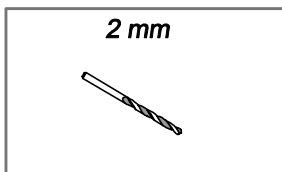
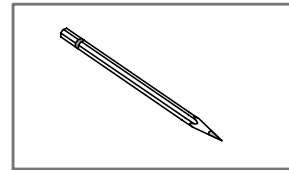
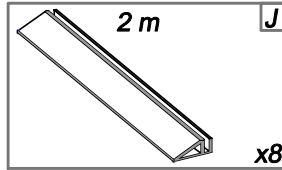
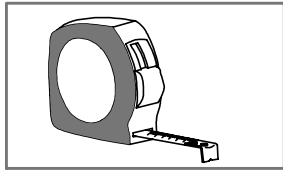
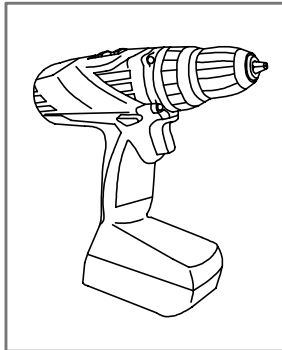

PL Profile PVC

GB PVC profiles

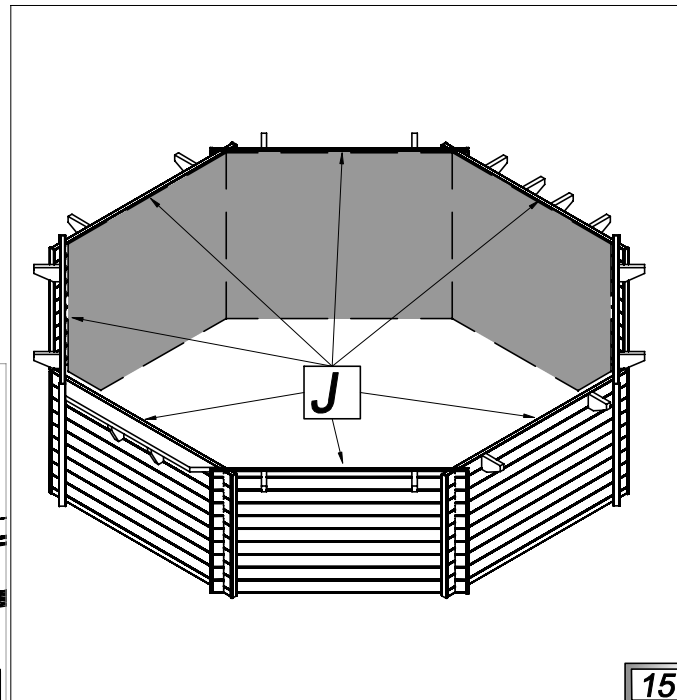
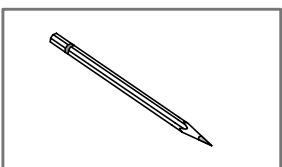
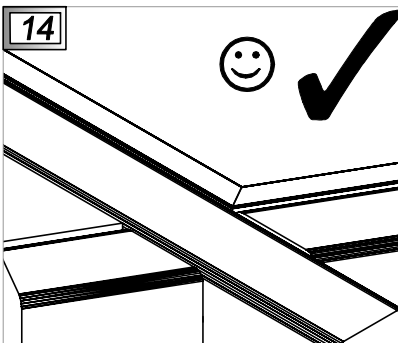
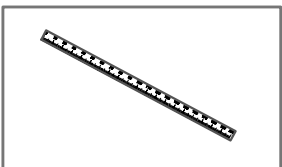
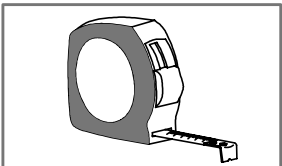
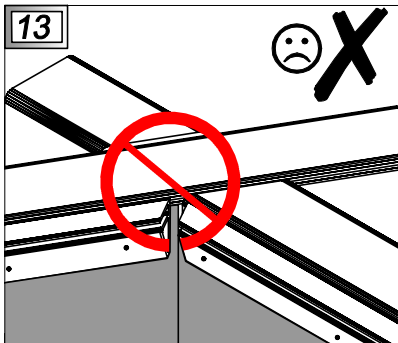
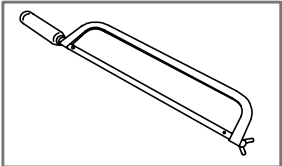
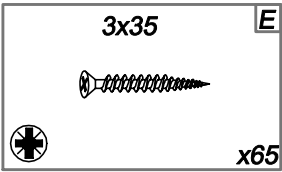
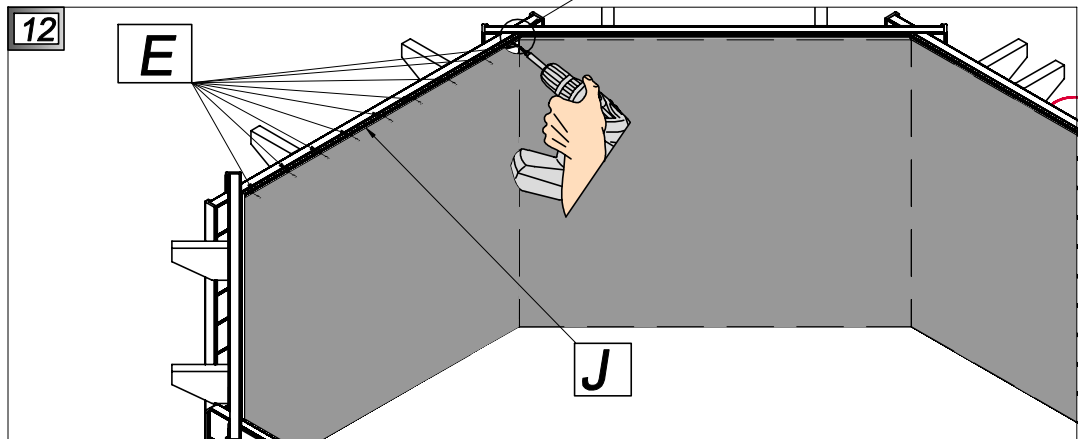
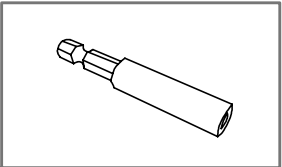
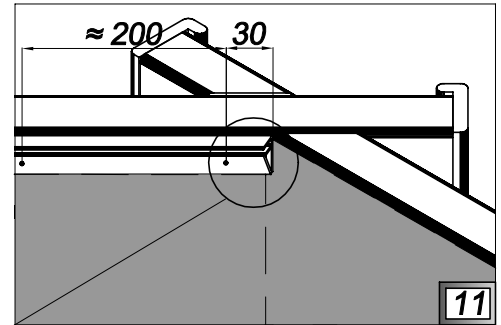
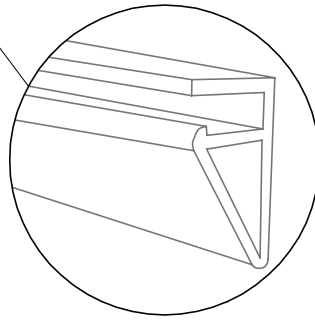
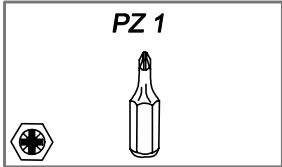
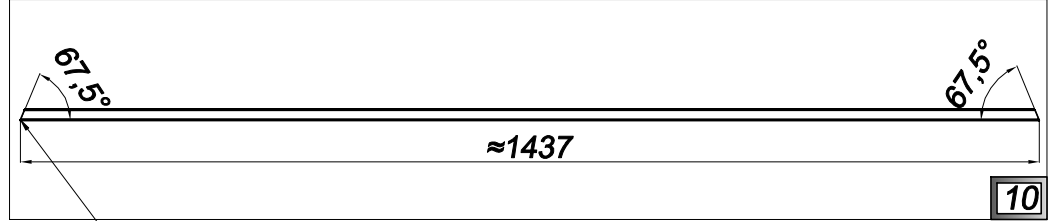
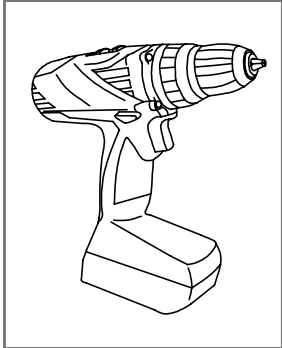

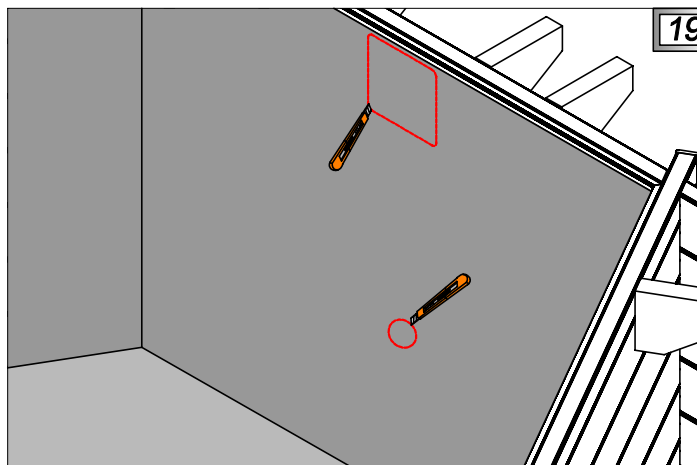
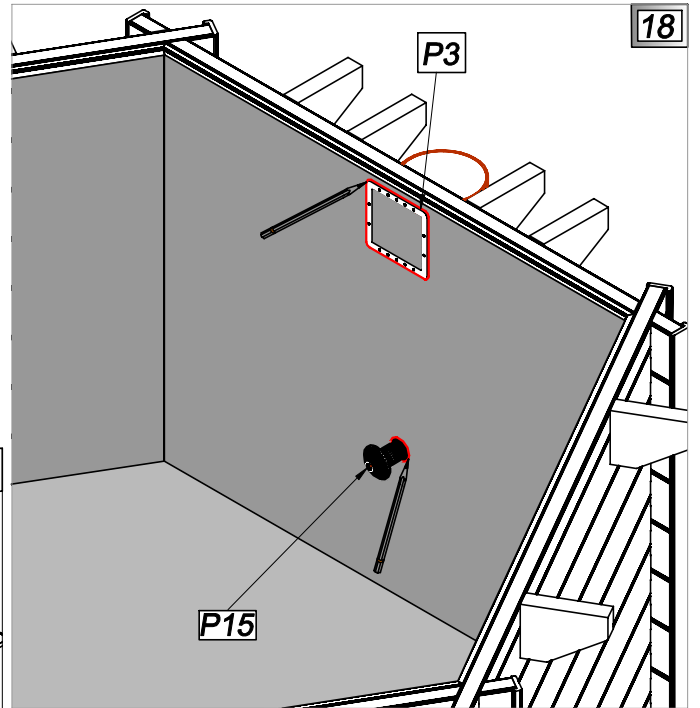
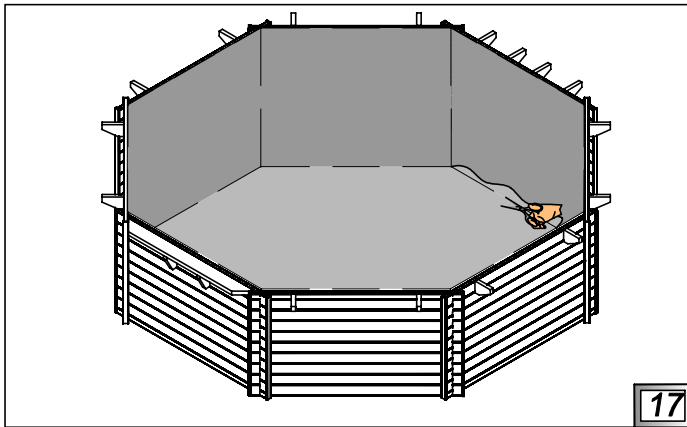
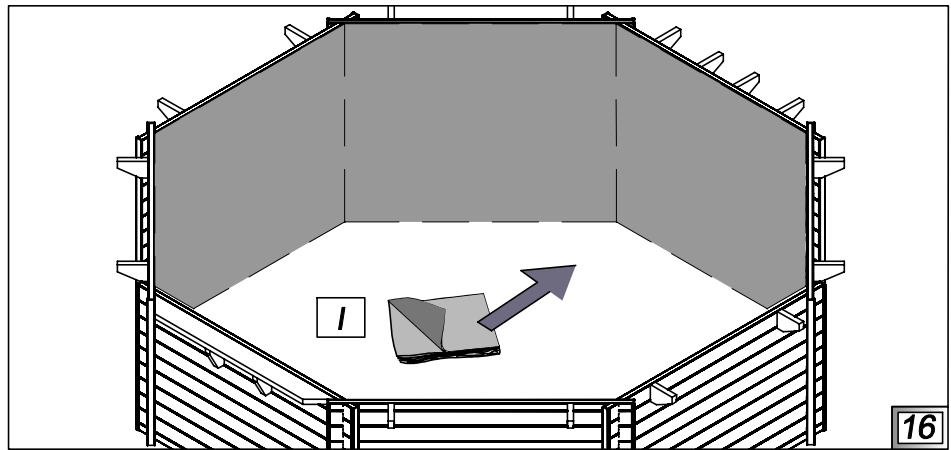
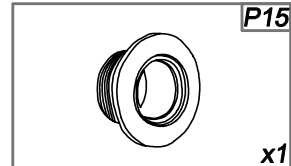
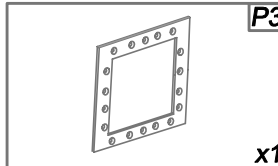
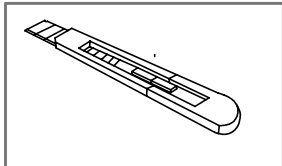
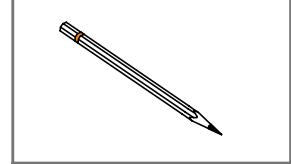
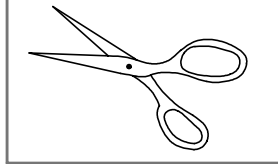
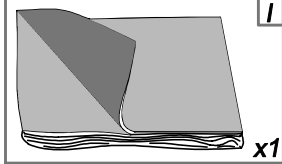
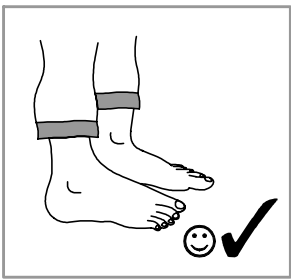

PL Liner

GB Liner

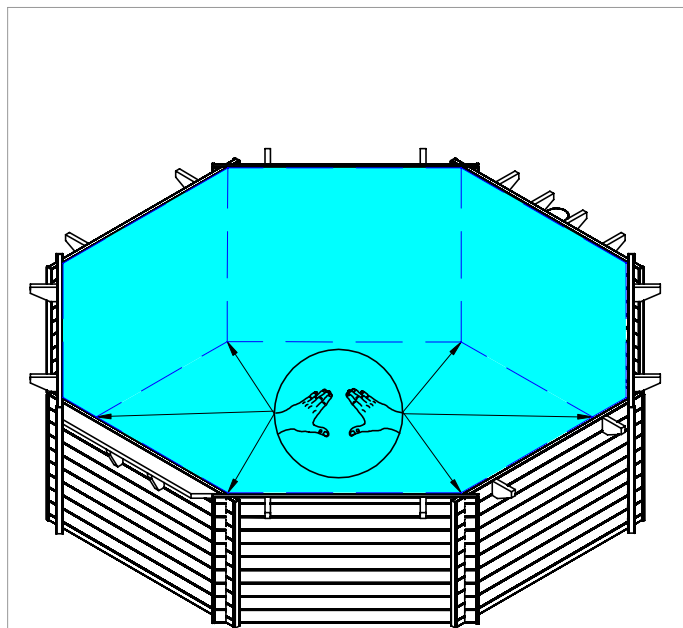
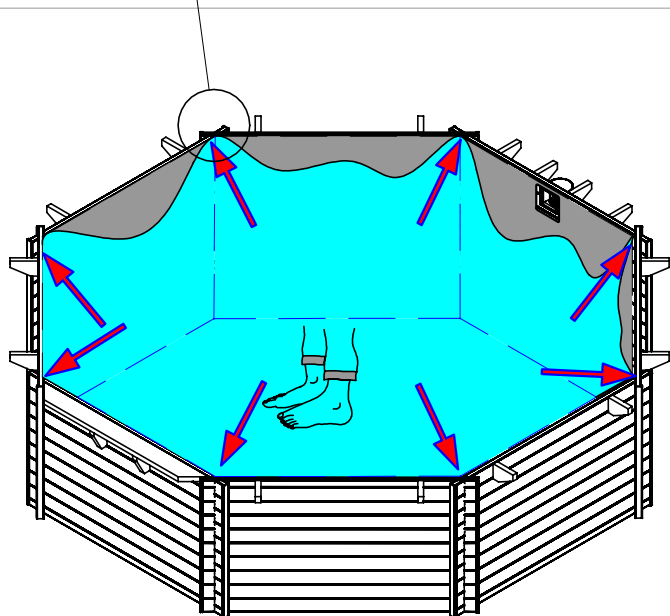
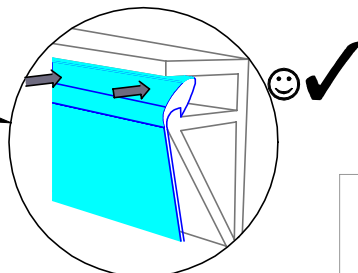
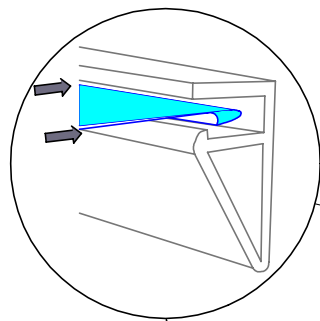
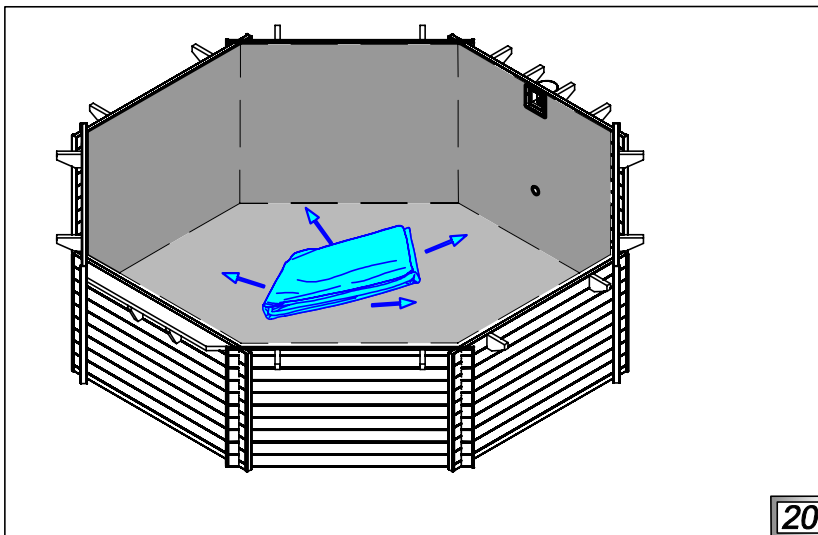
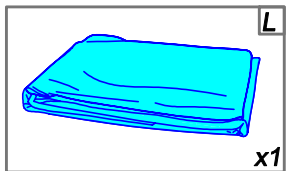

PL Liner

GB Liner

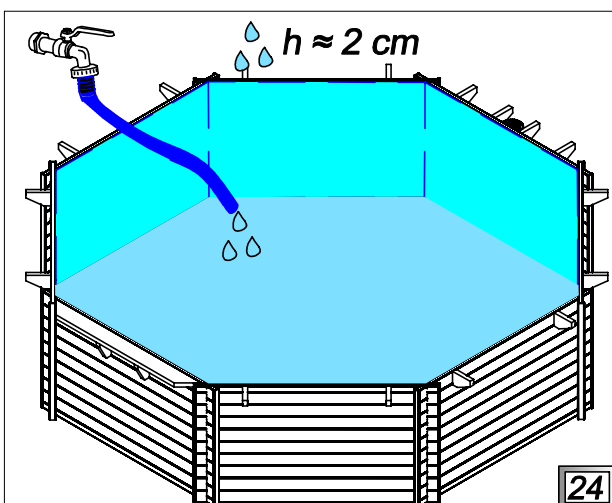
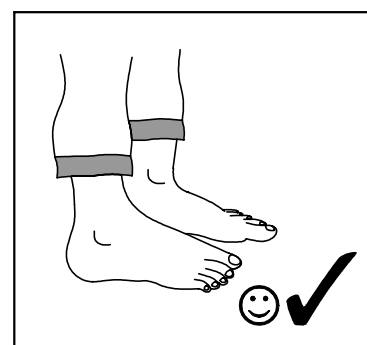
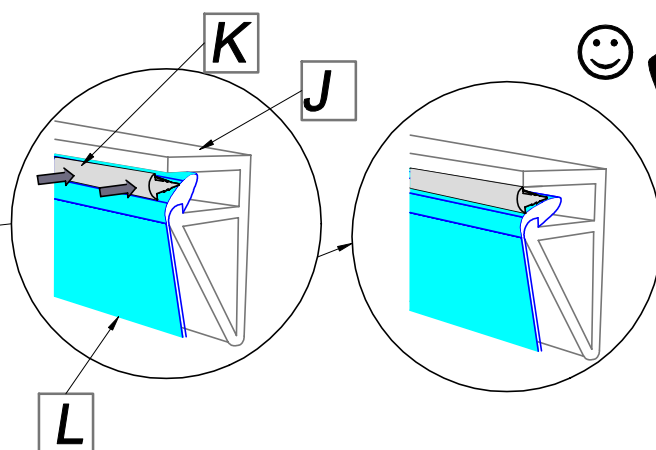
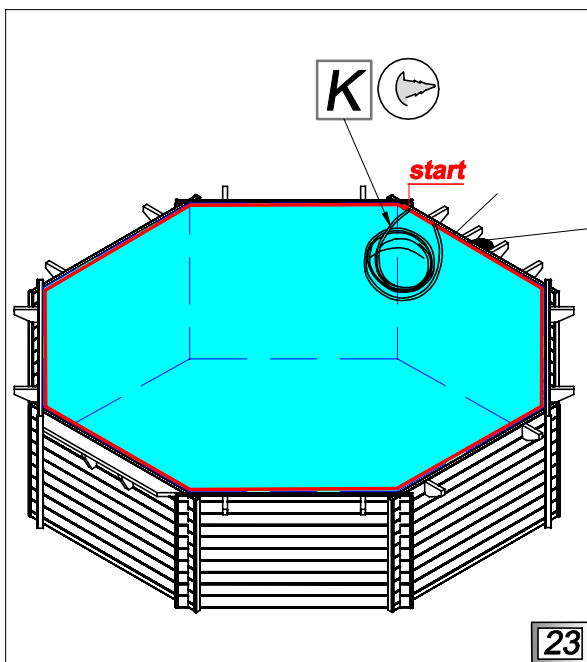
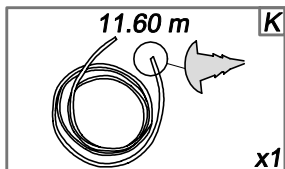
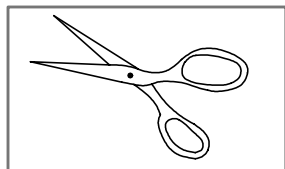

PL Wyrównaj sfaldowania po nalaniu wody.

GB Smooth all folds after pouring water.

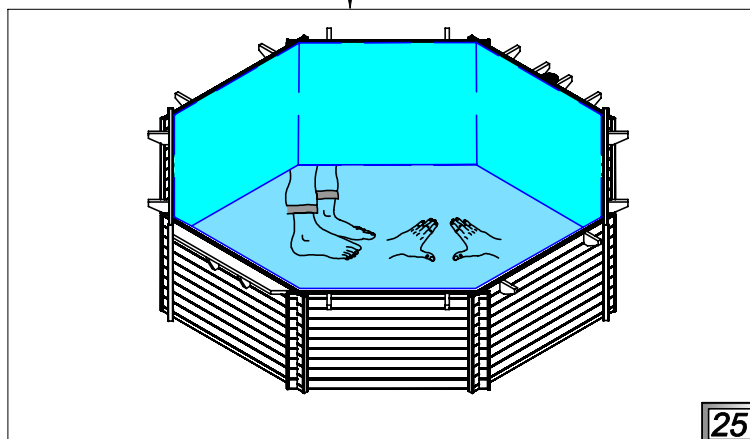
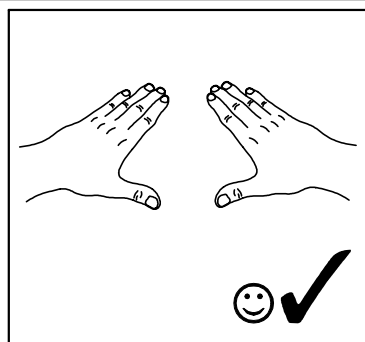

25

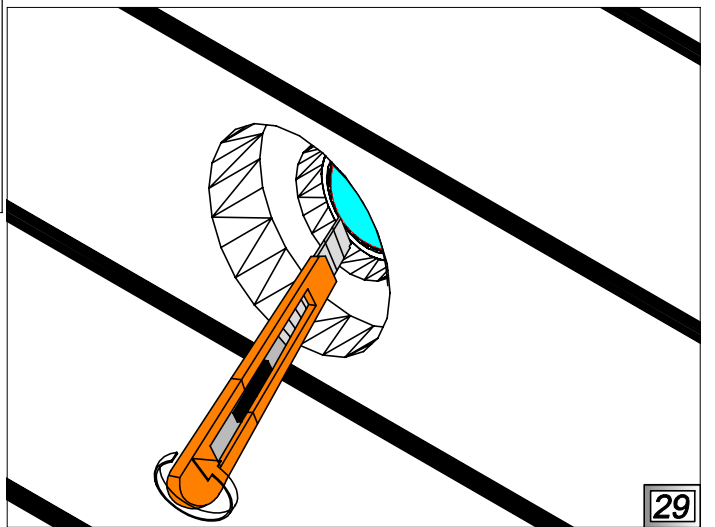
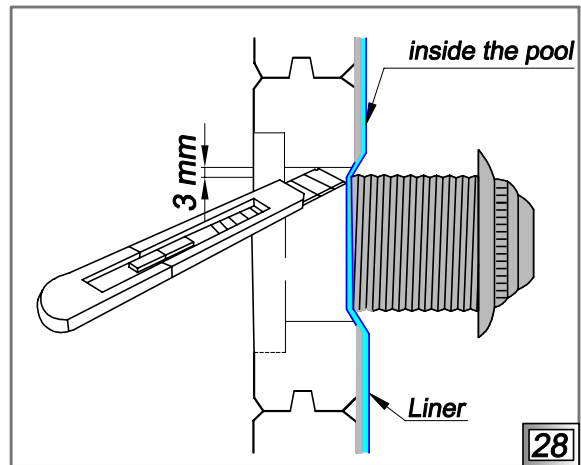
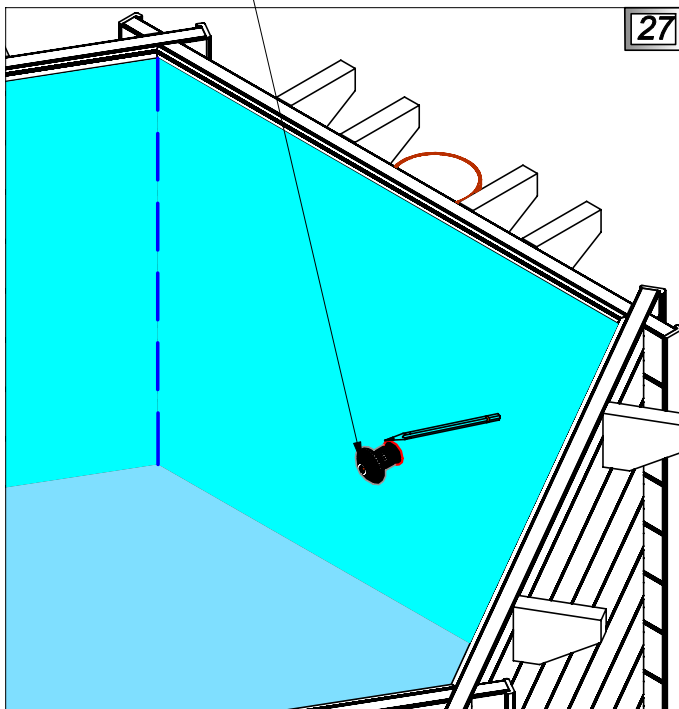
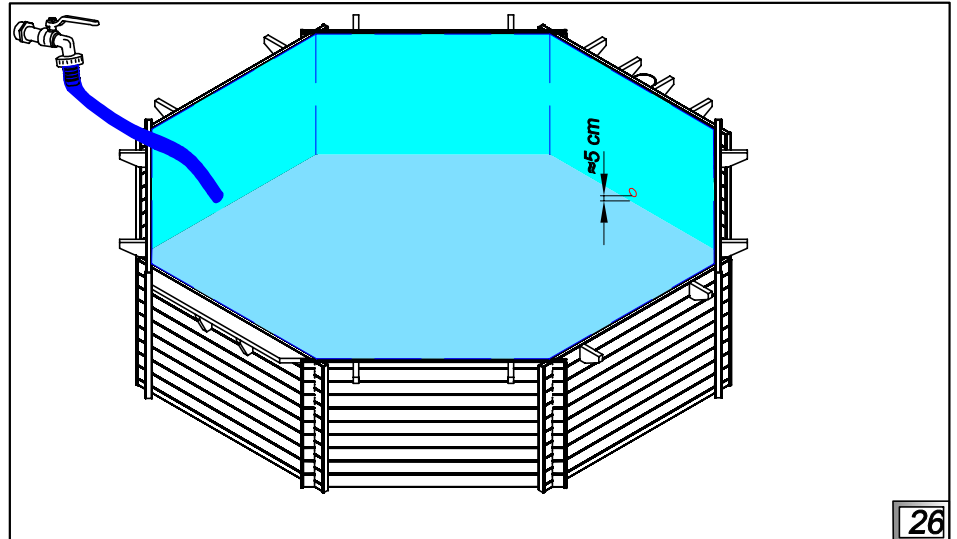
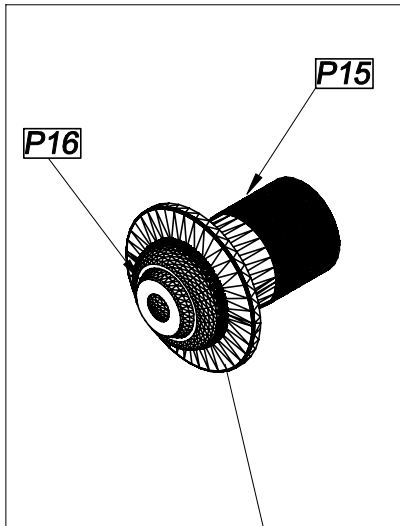
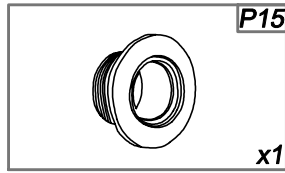
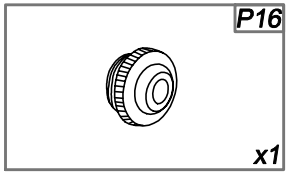

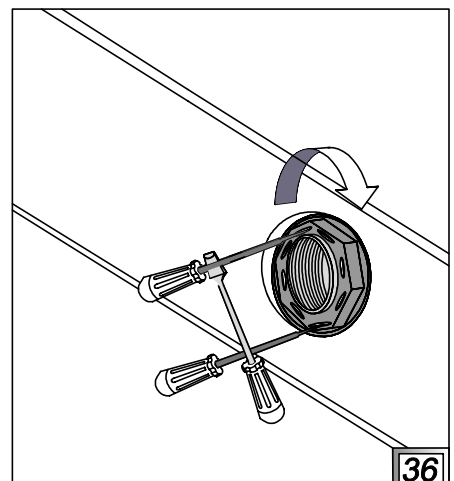
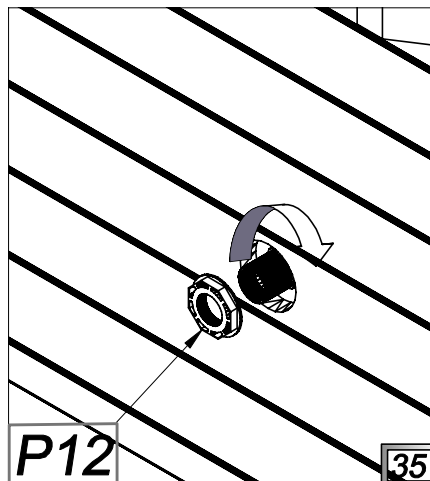
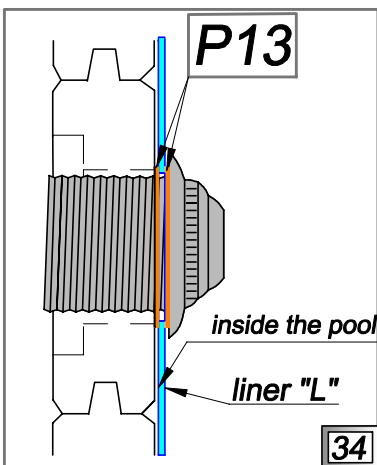
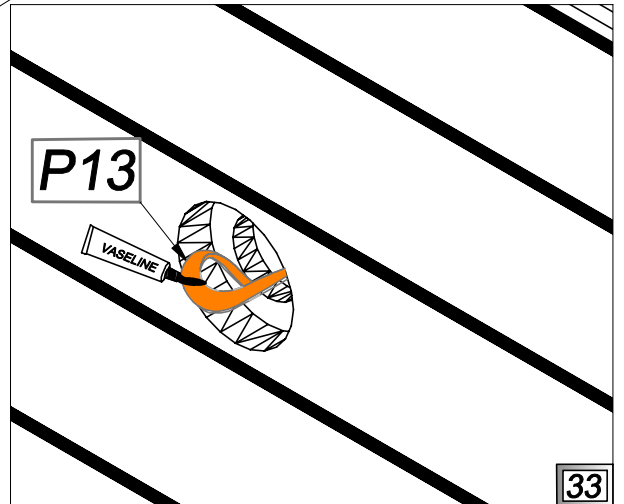
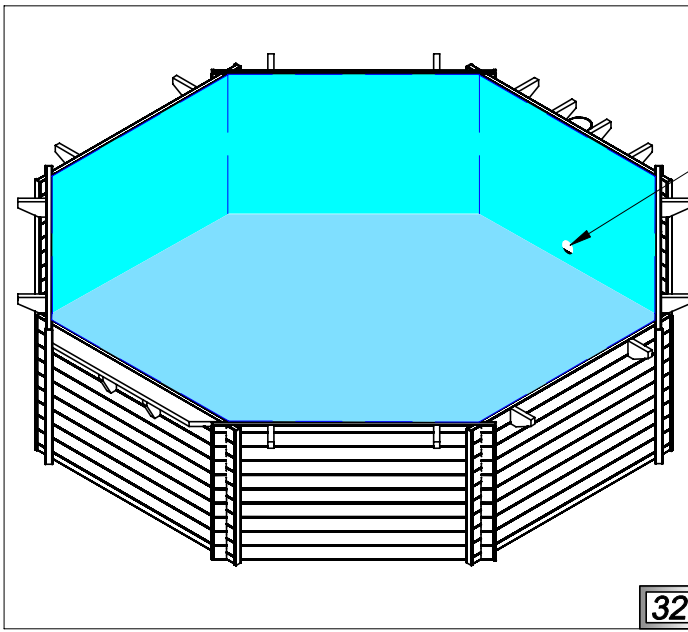
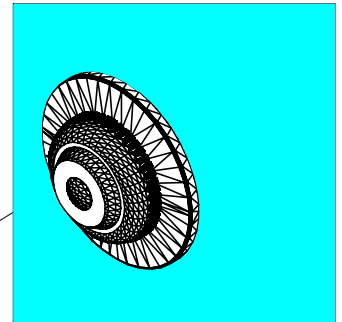
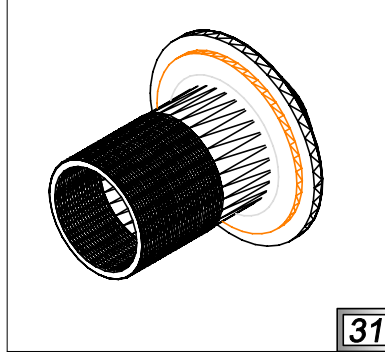
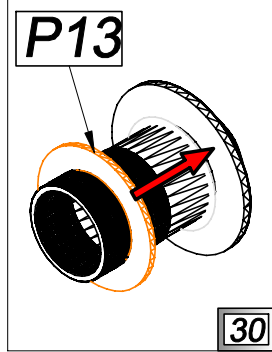
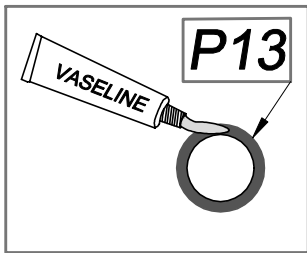
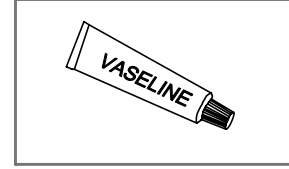
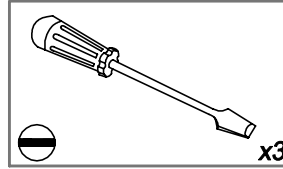
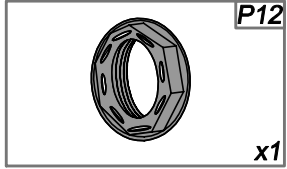
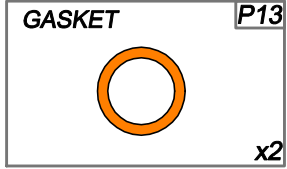

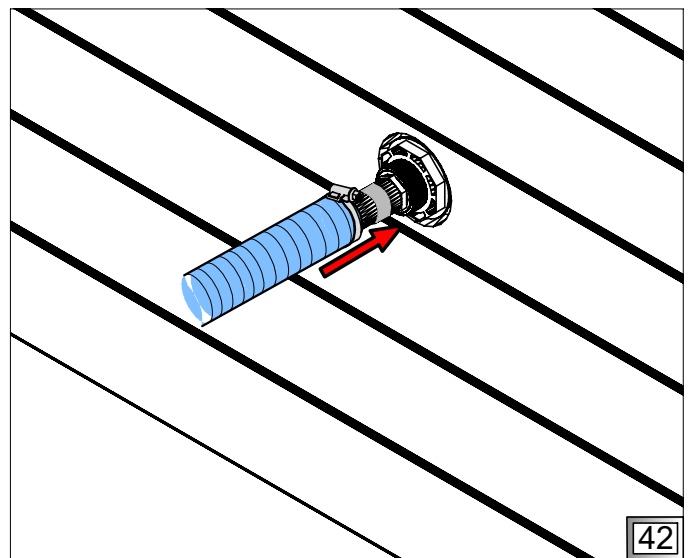
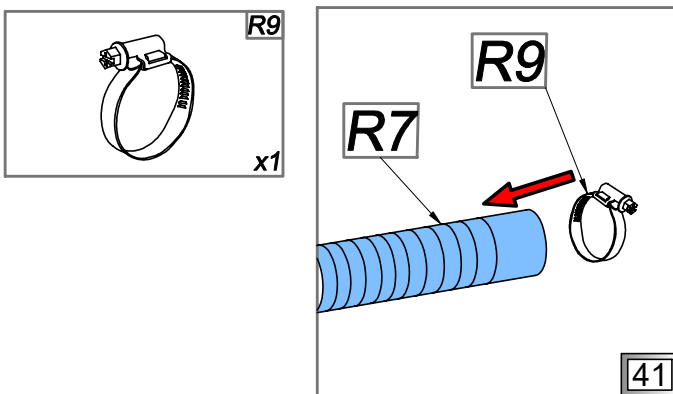
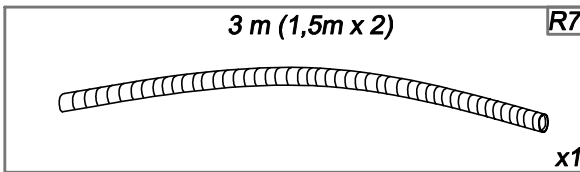
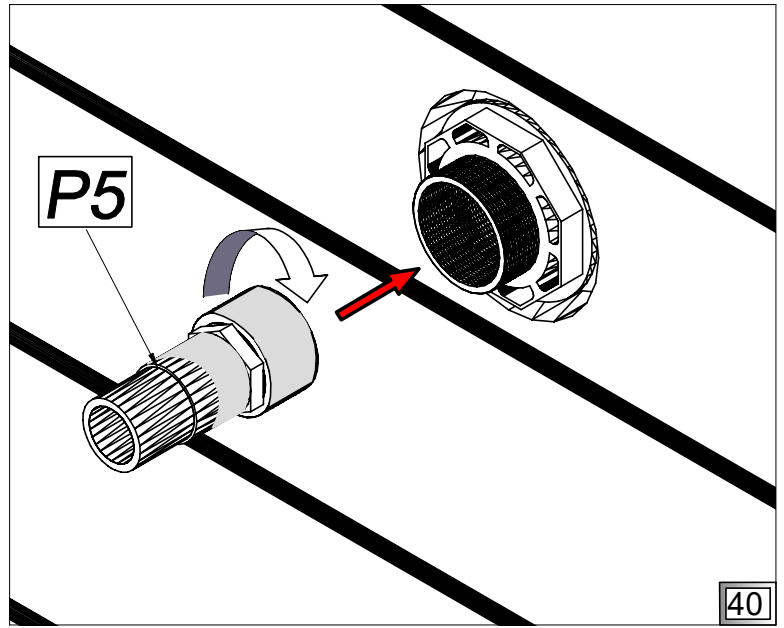
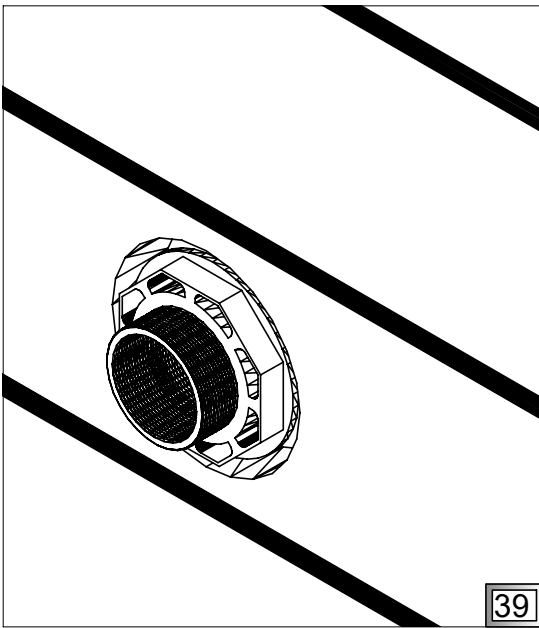
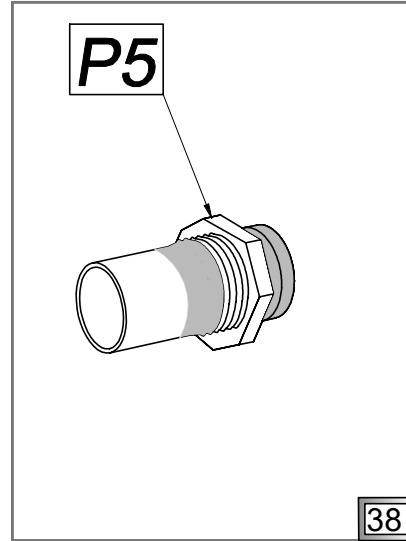
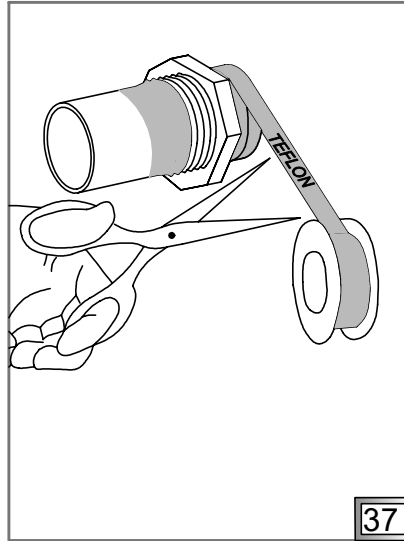
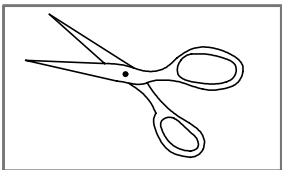
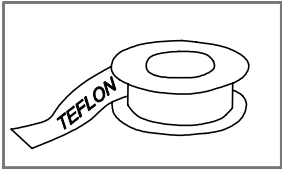
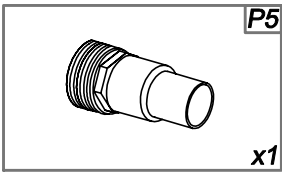

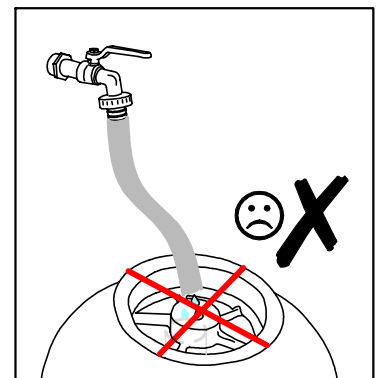
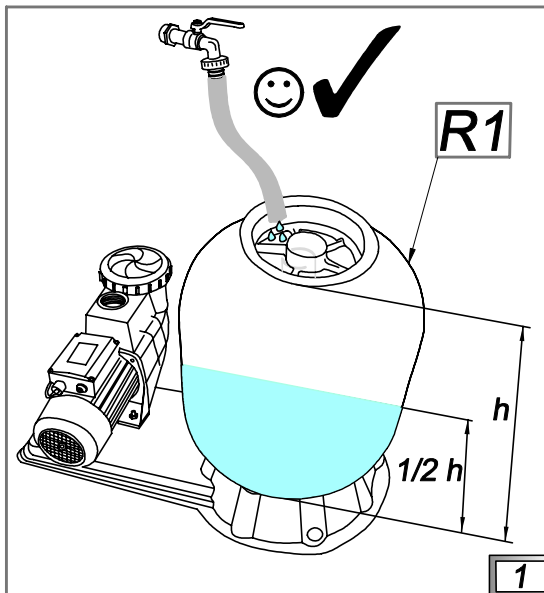
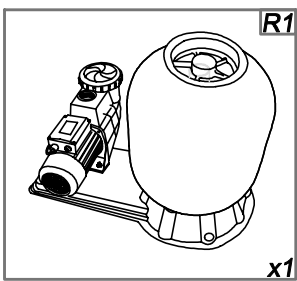
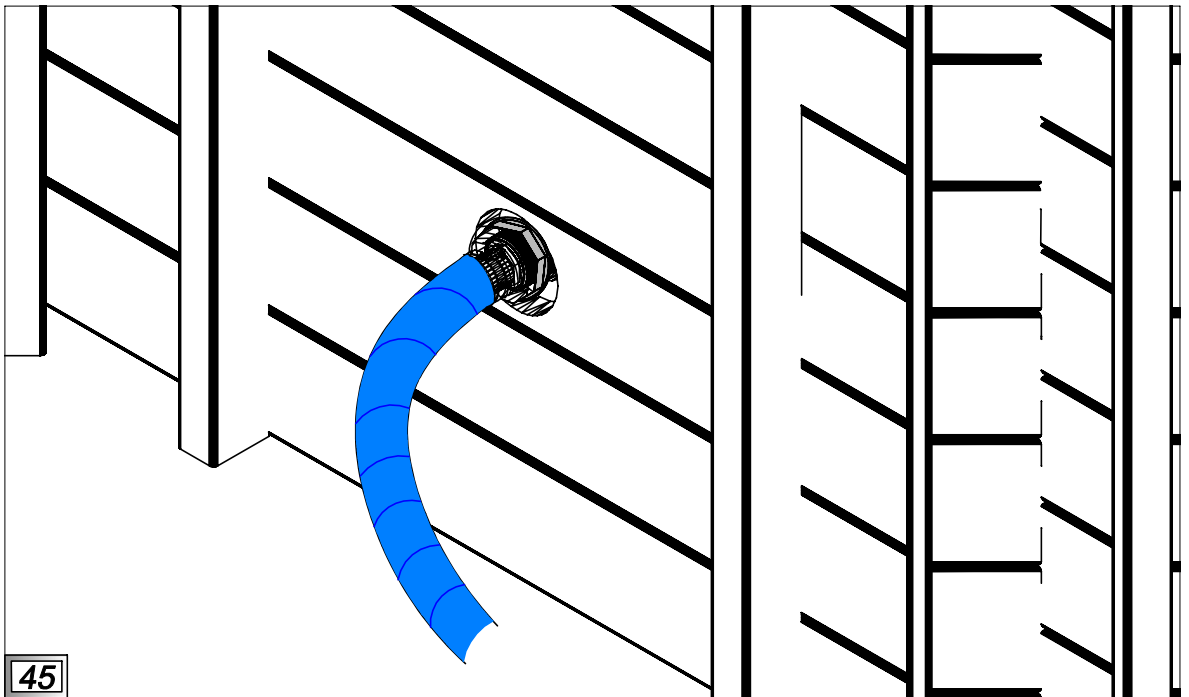
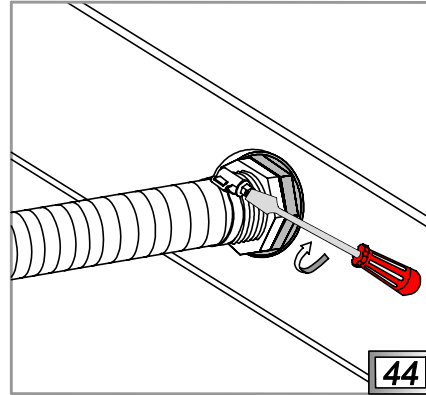
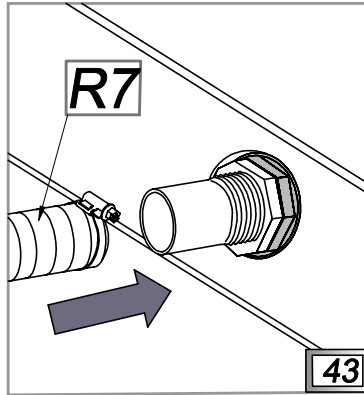
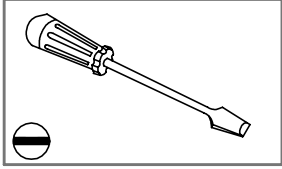

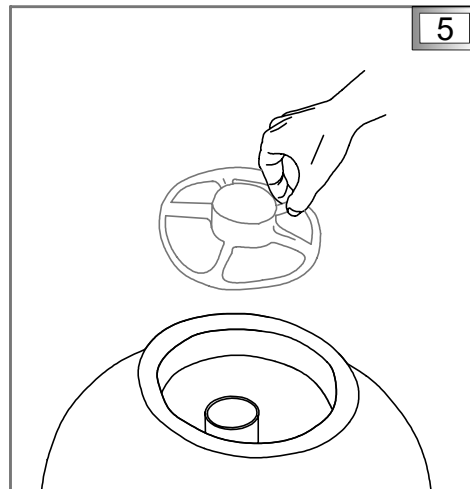
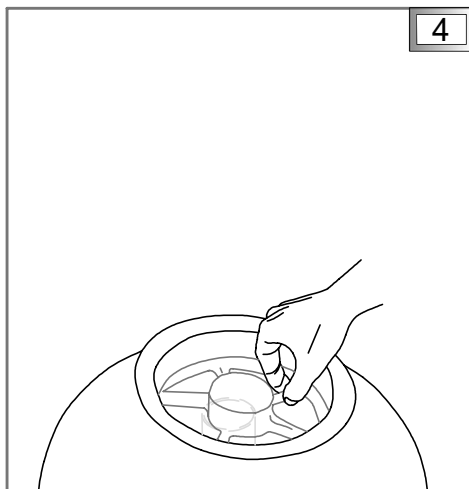
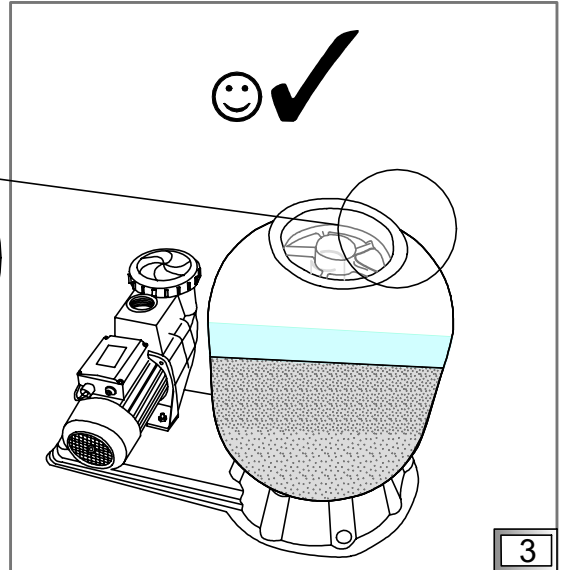
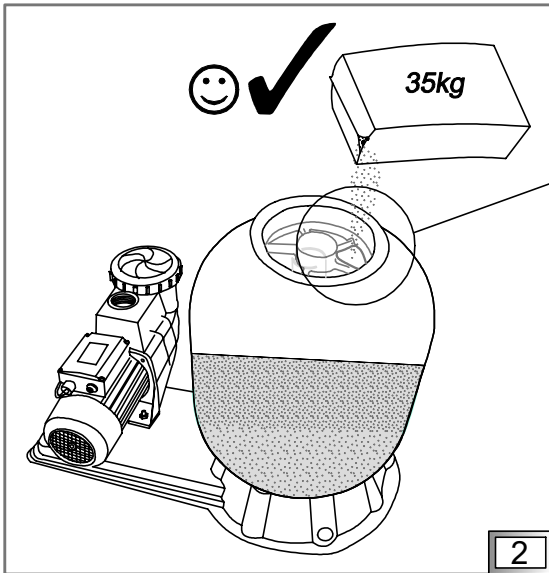
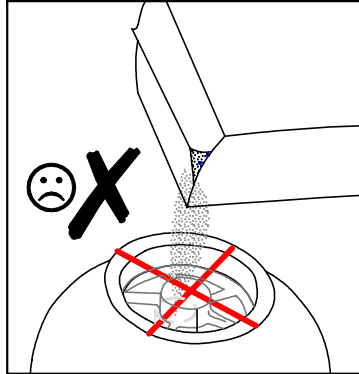
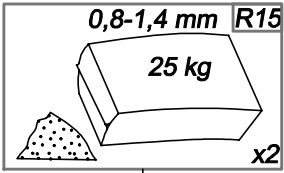

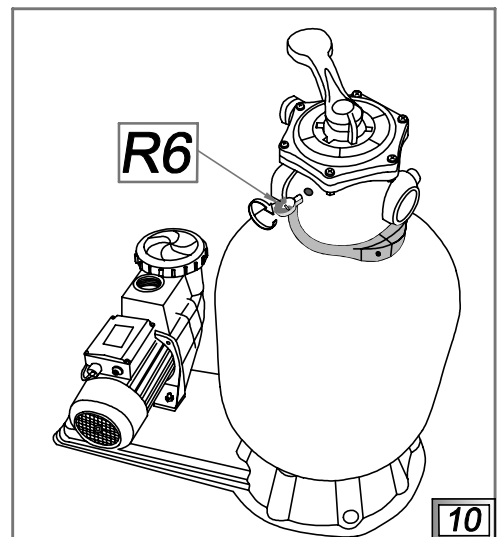
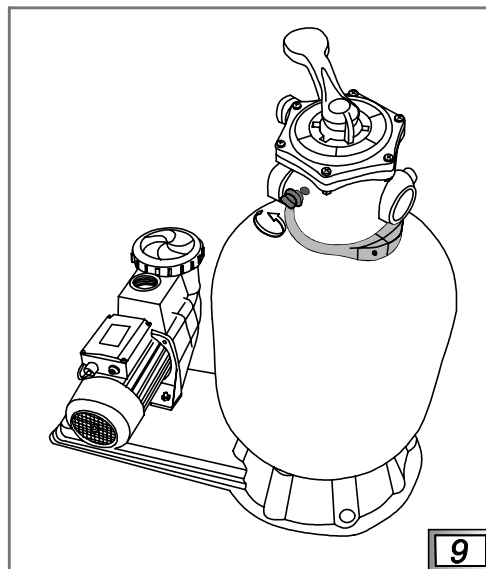
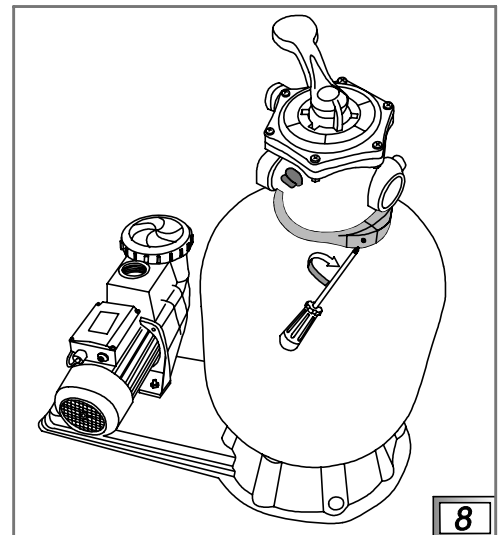
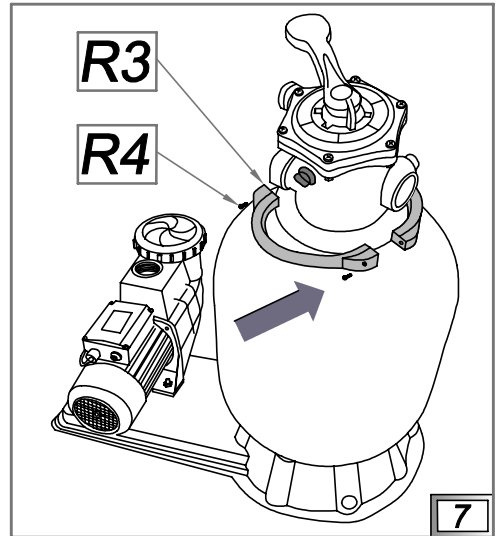
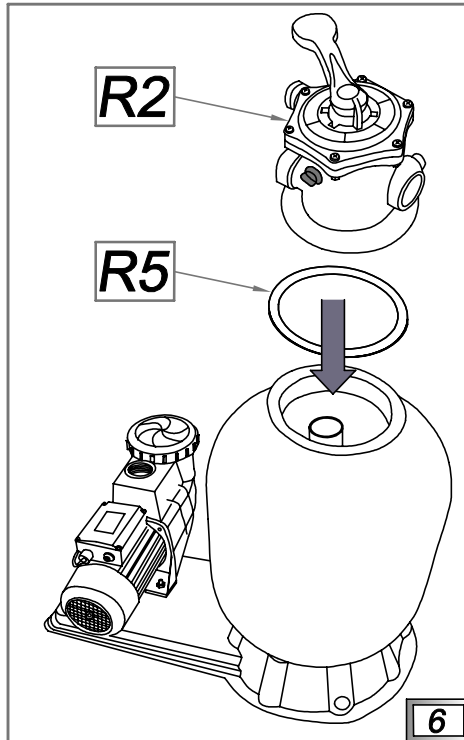
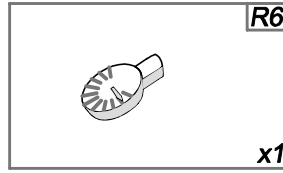
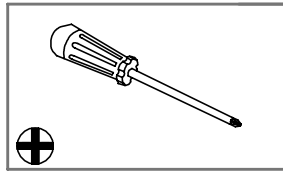
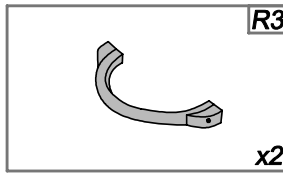
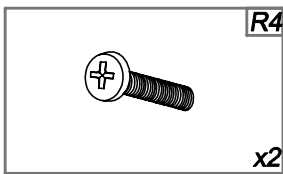
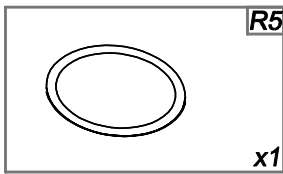
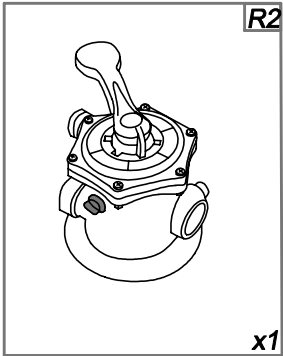

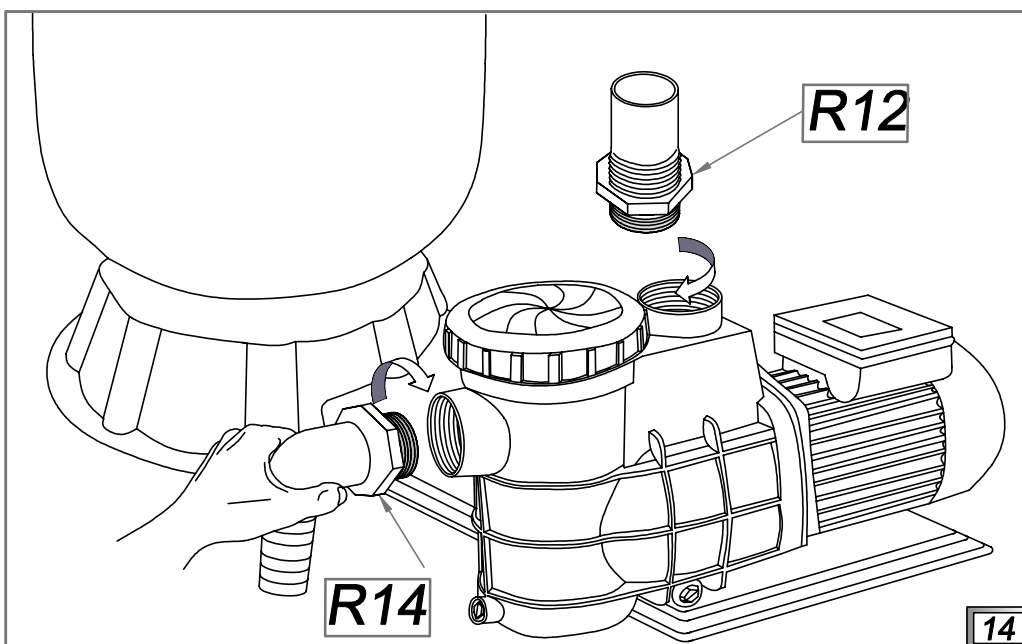
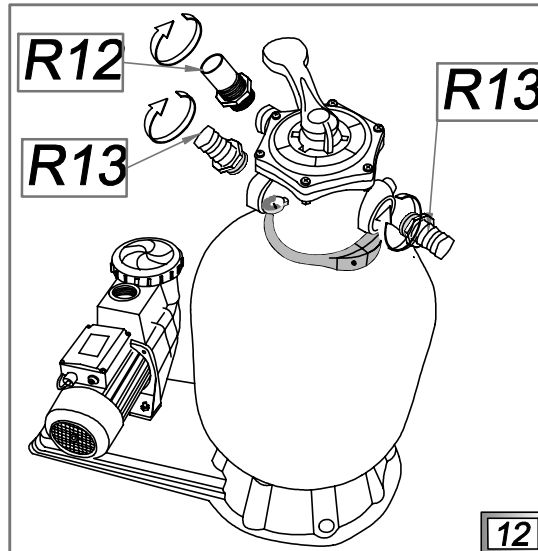
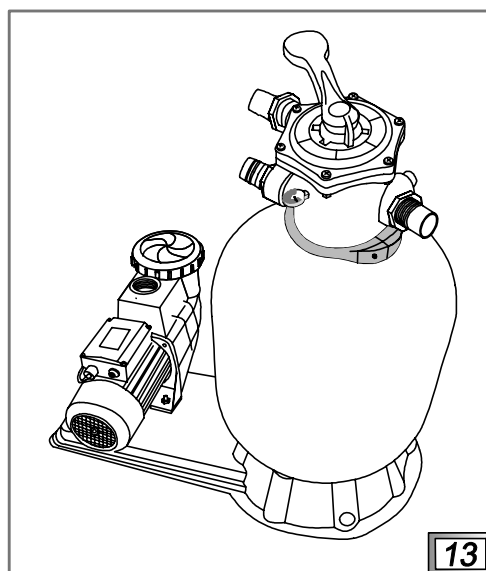
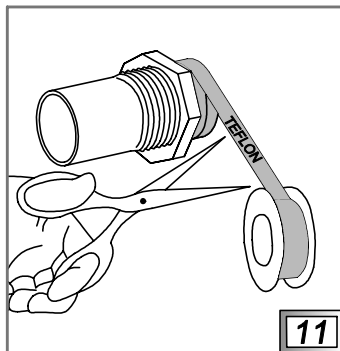
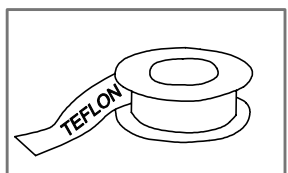
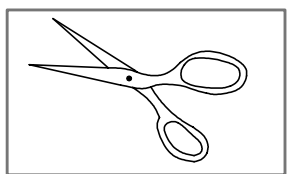
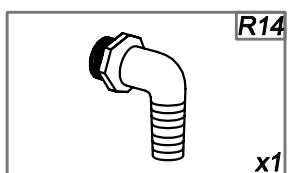
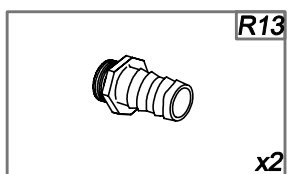
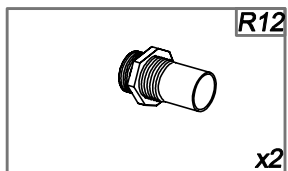

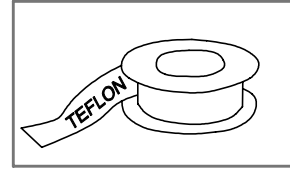
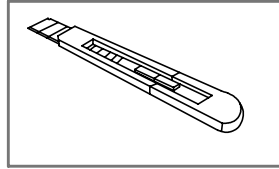
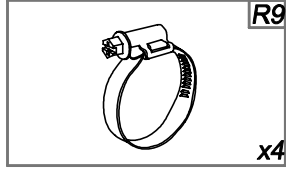
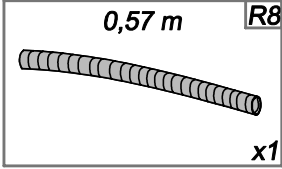

R9

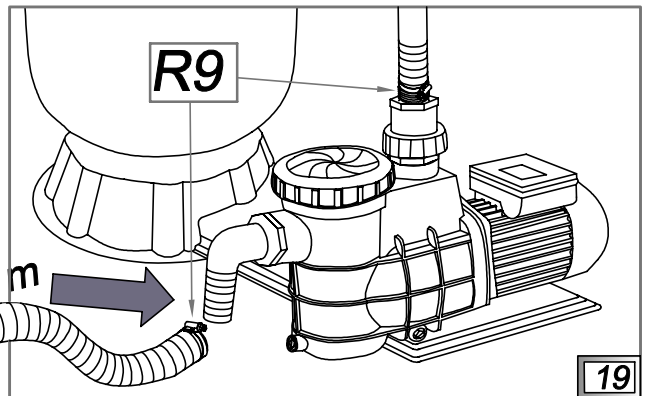
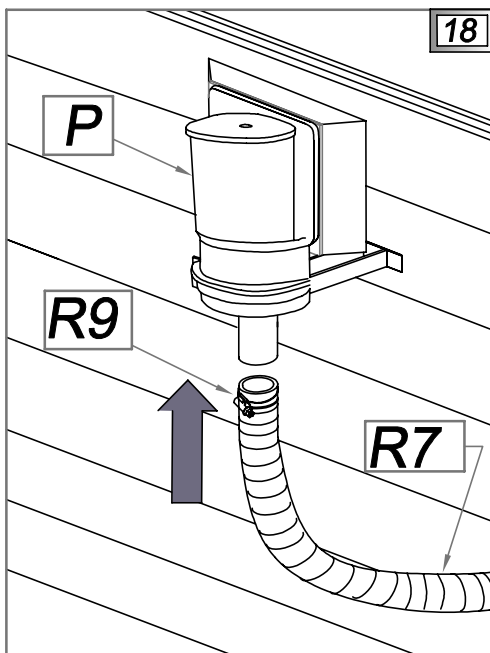
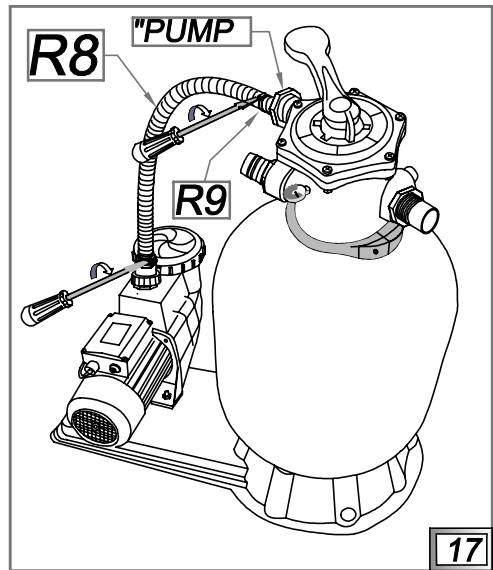
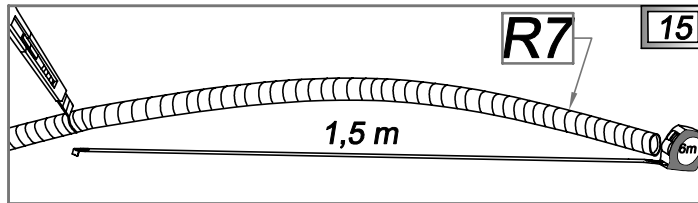
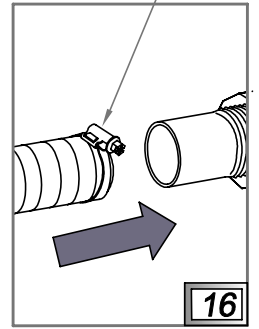
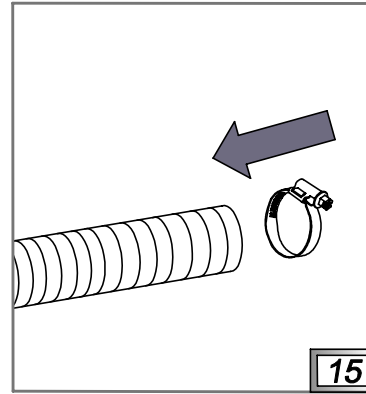
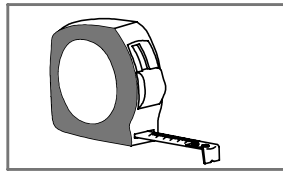
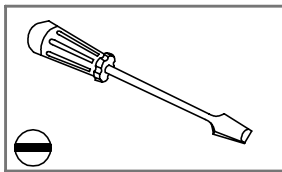
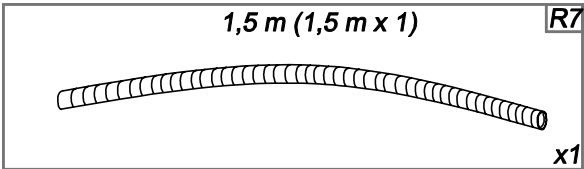

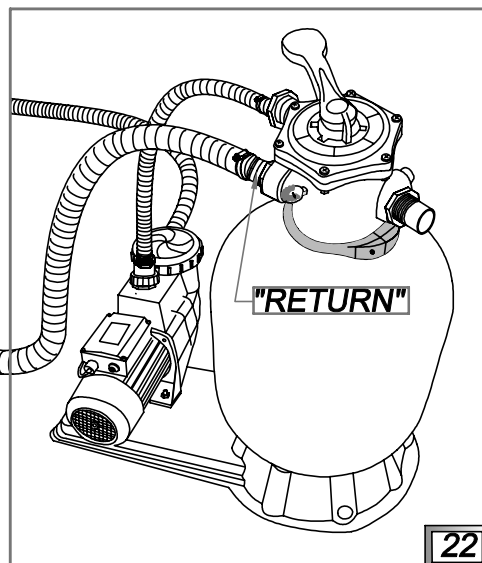
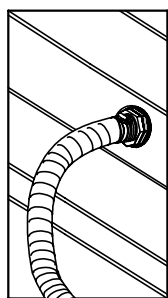
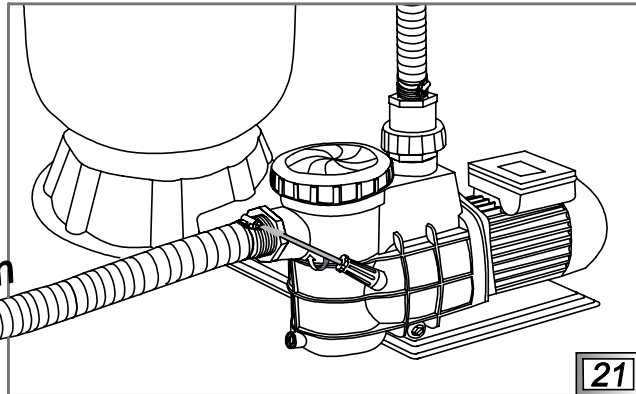
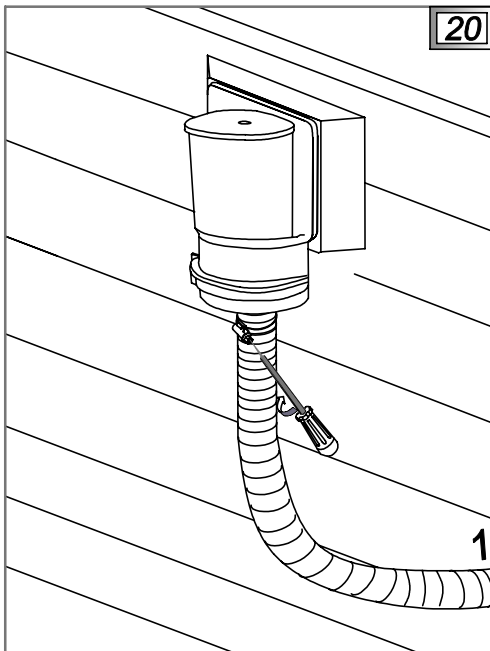
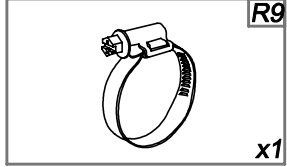
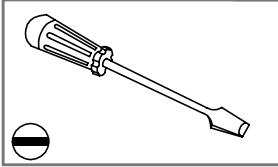

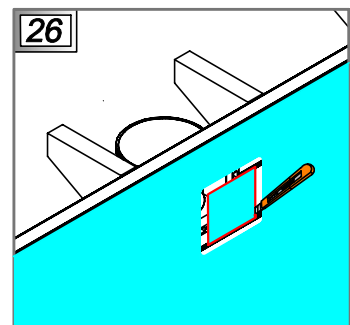
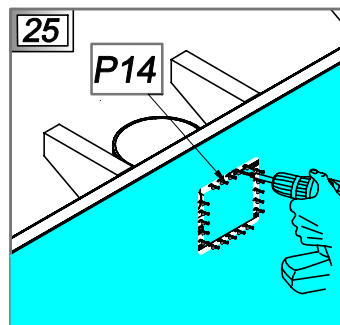
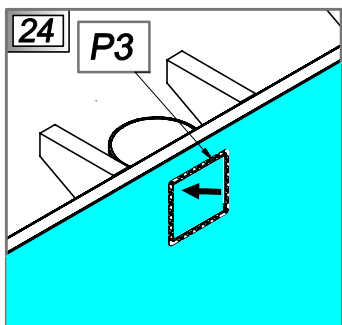
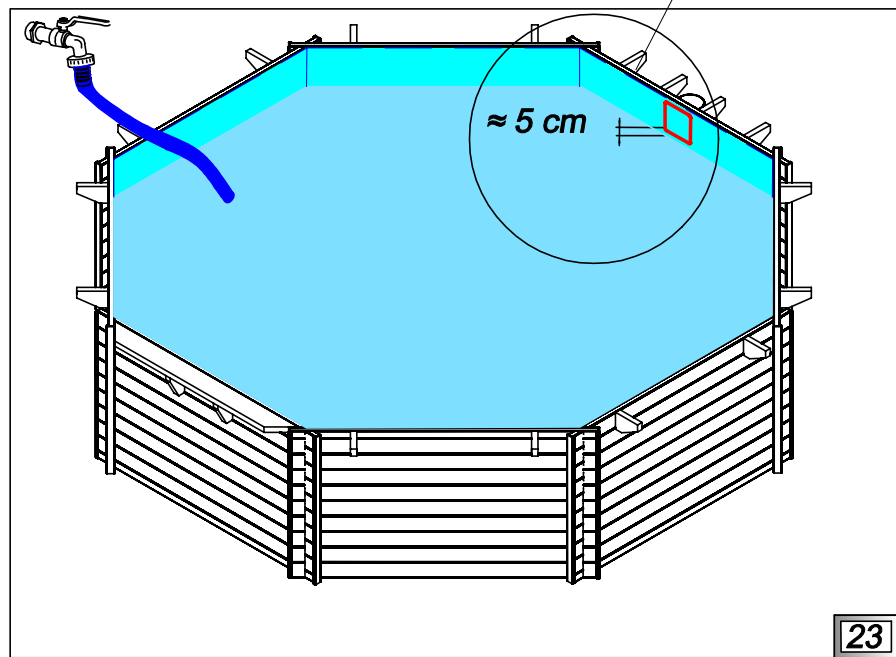
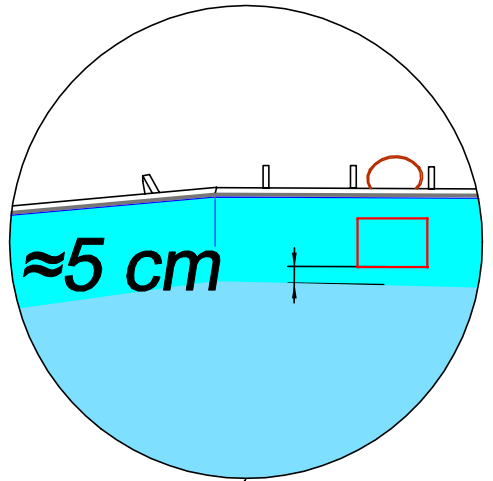
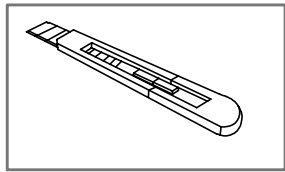
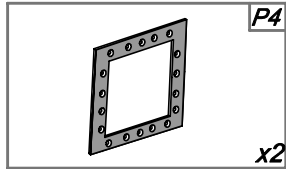
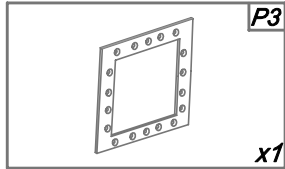
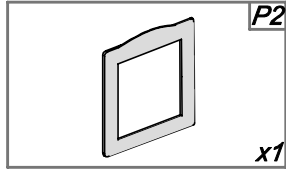
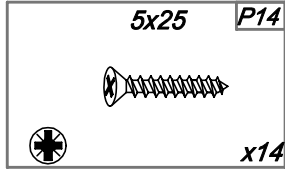

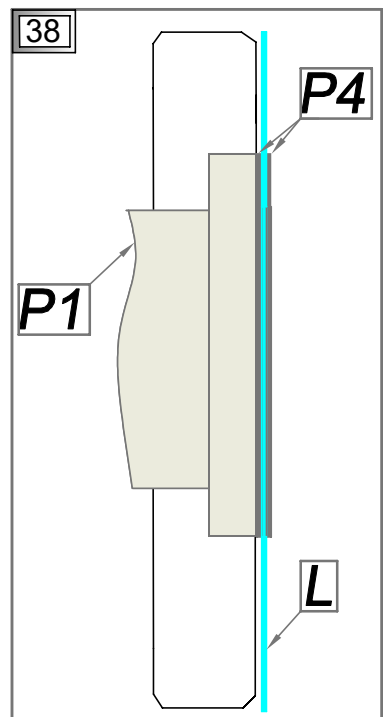
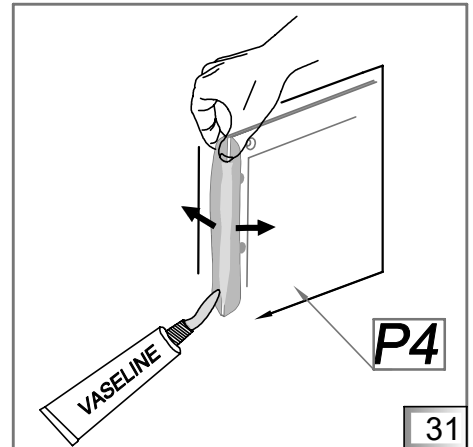
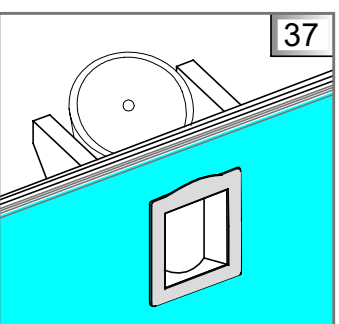
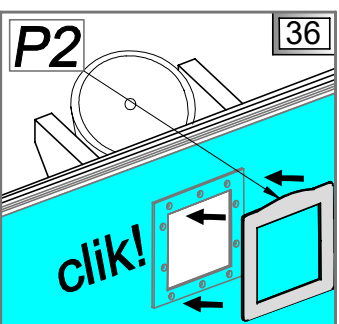
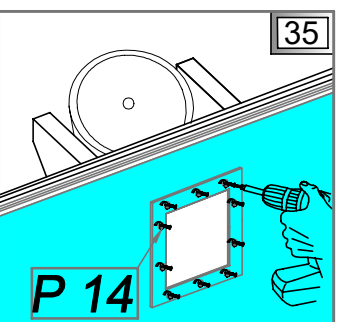
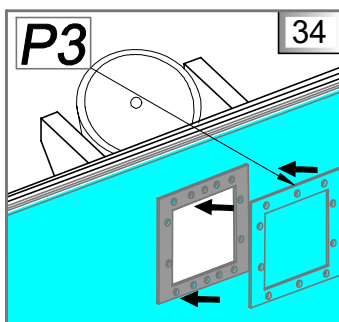
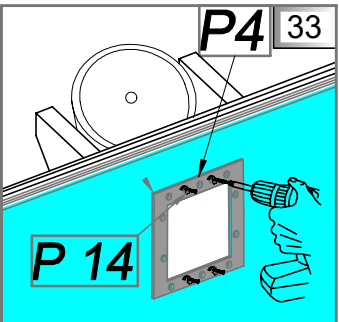
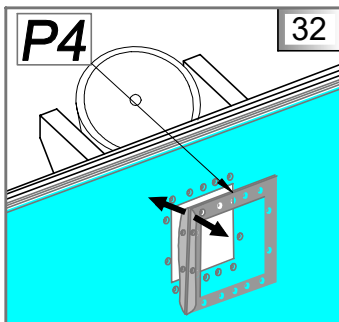
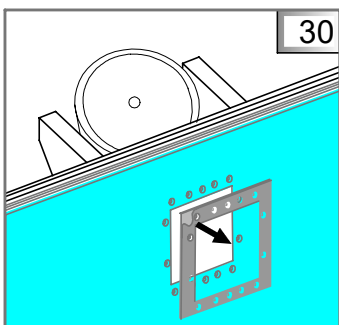
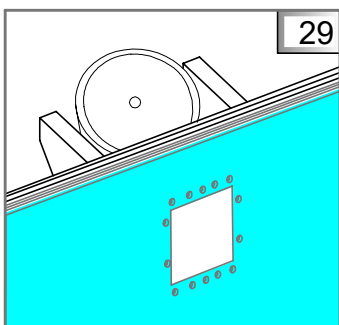
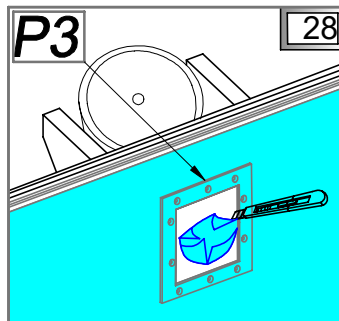
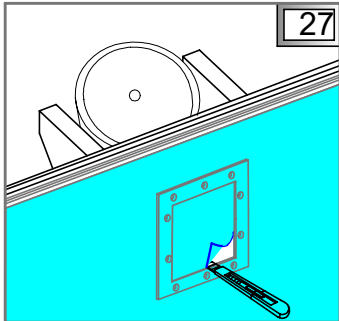

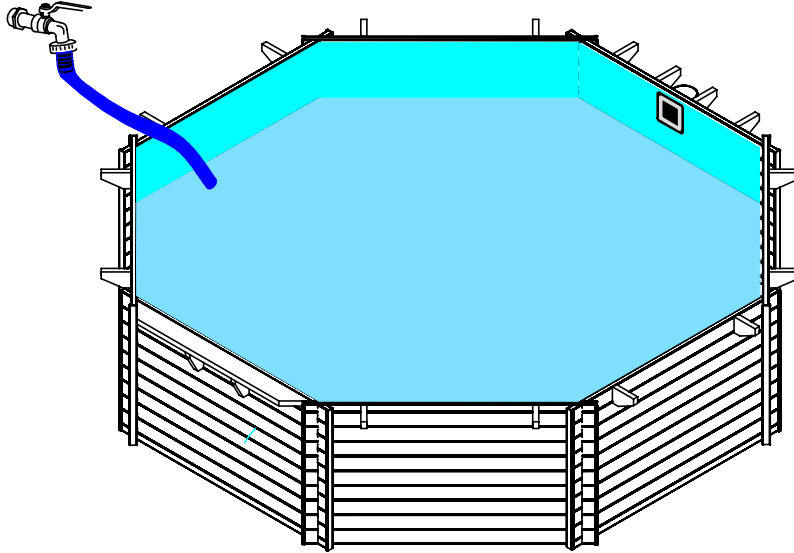

39

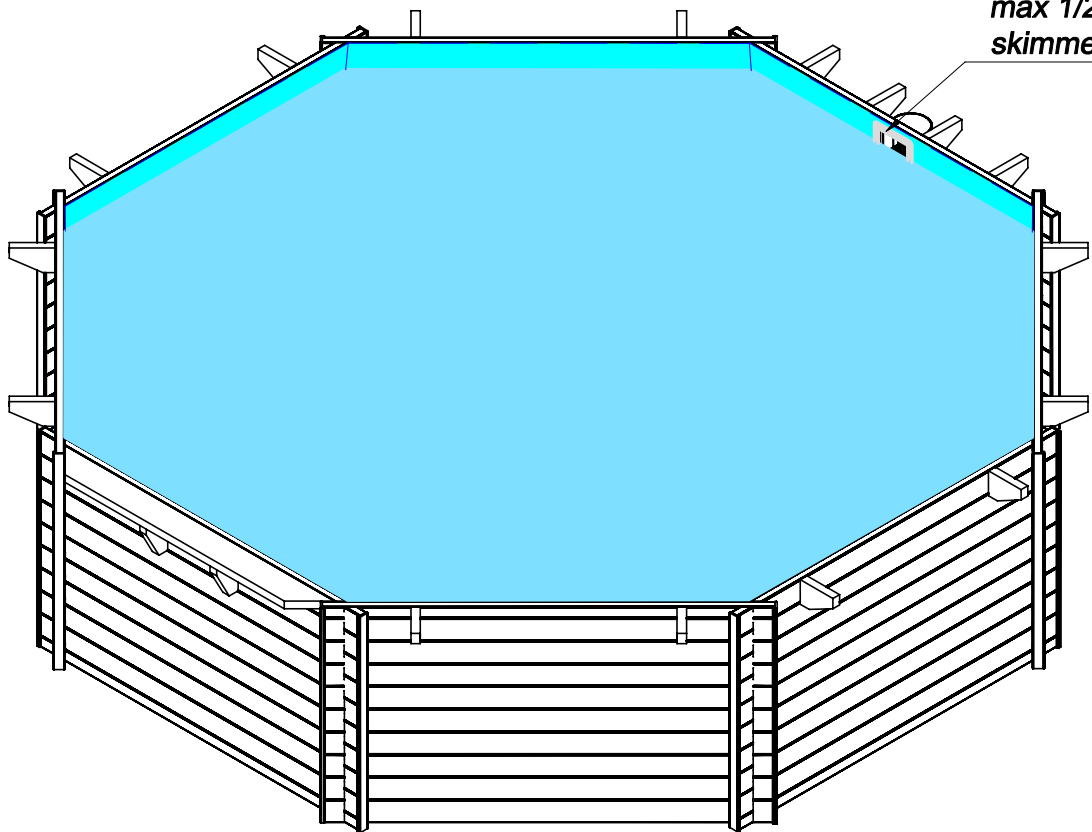

max 1/2 h  
skimmer

40

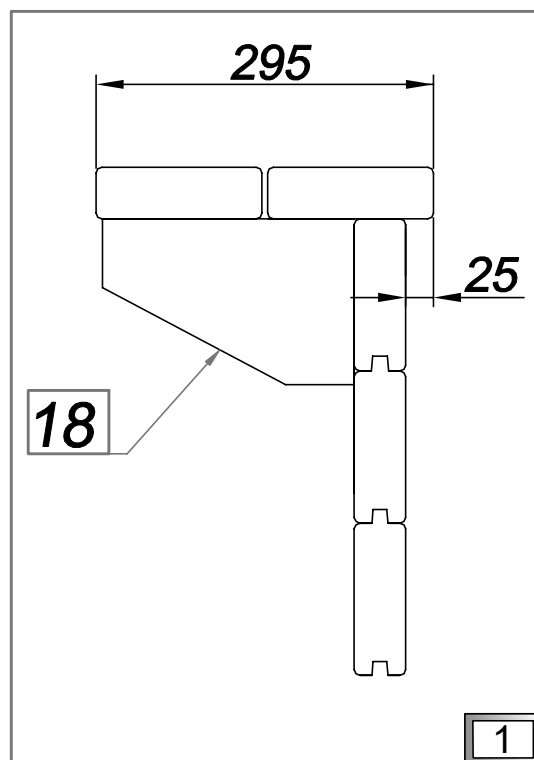
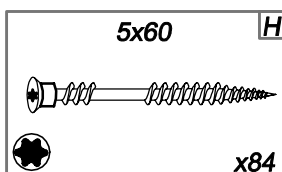
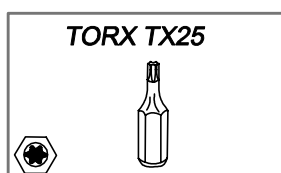
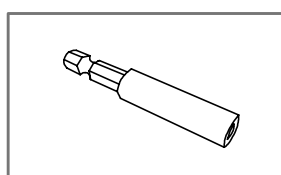
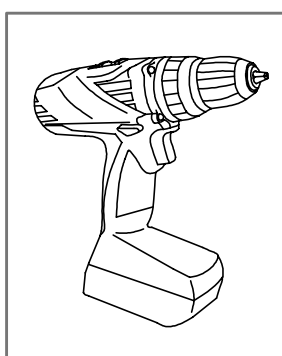
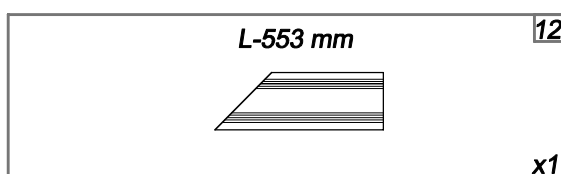
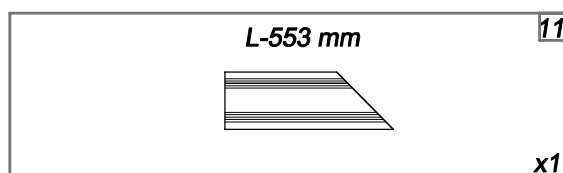
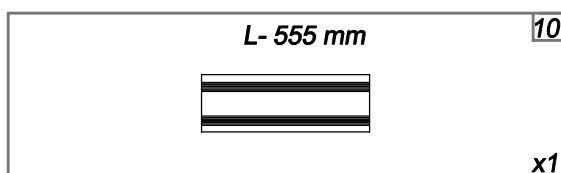
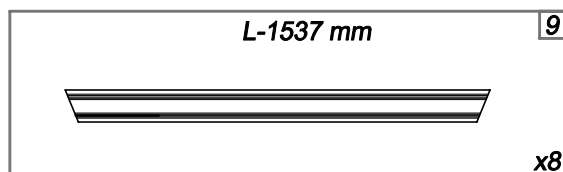
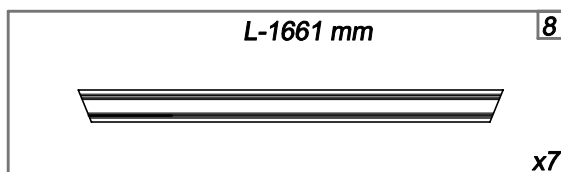

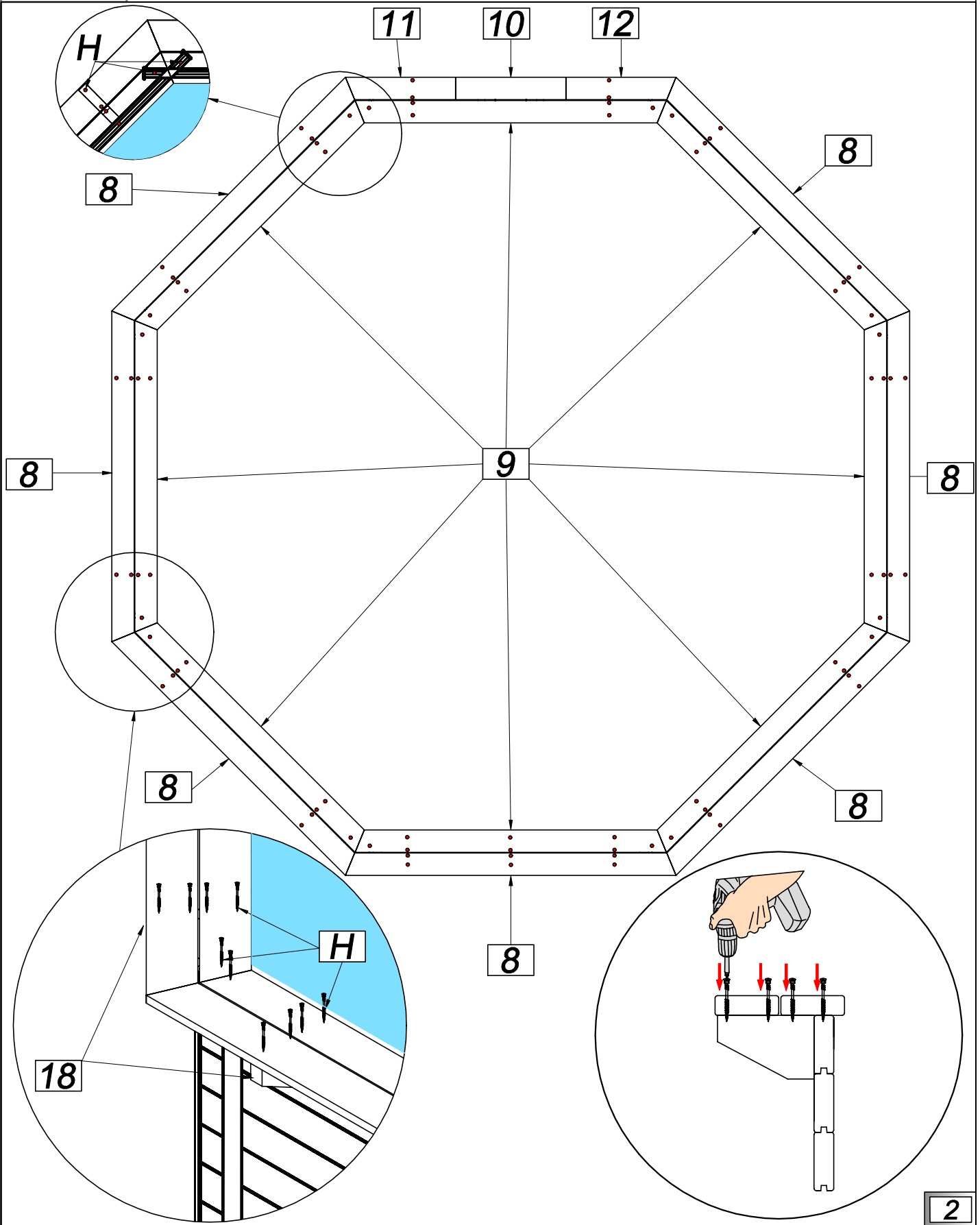

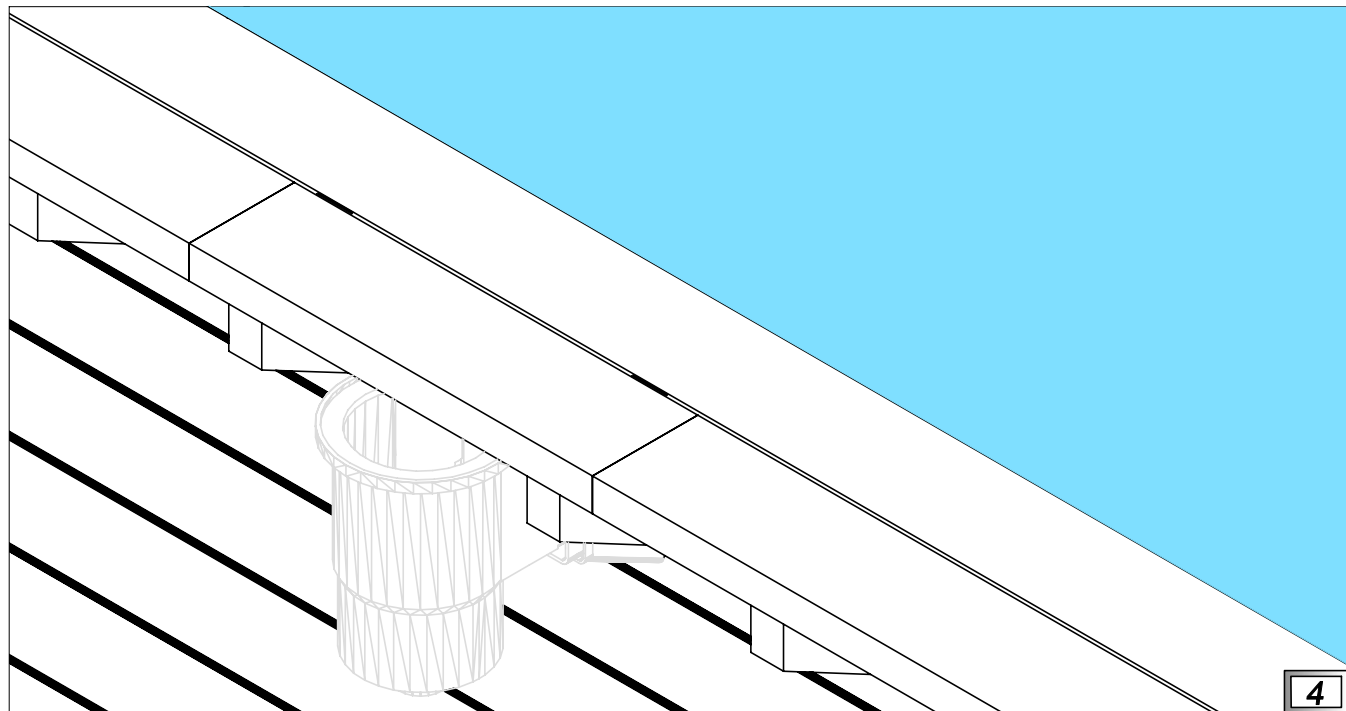
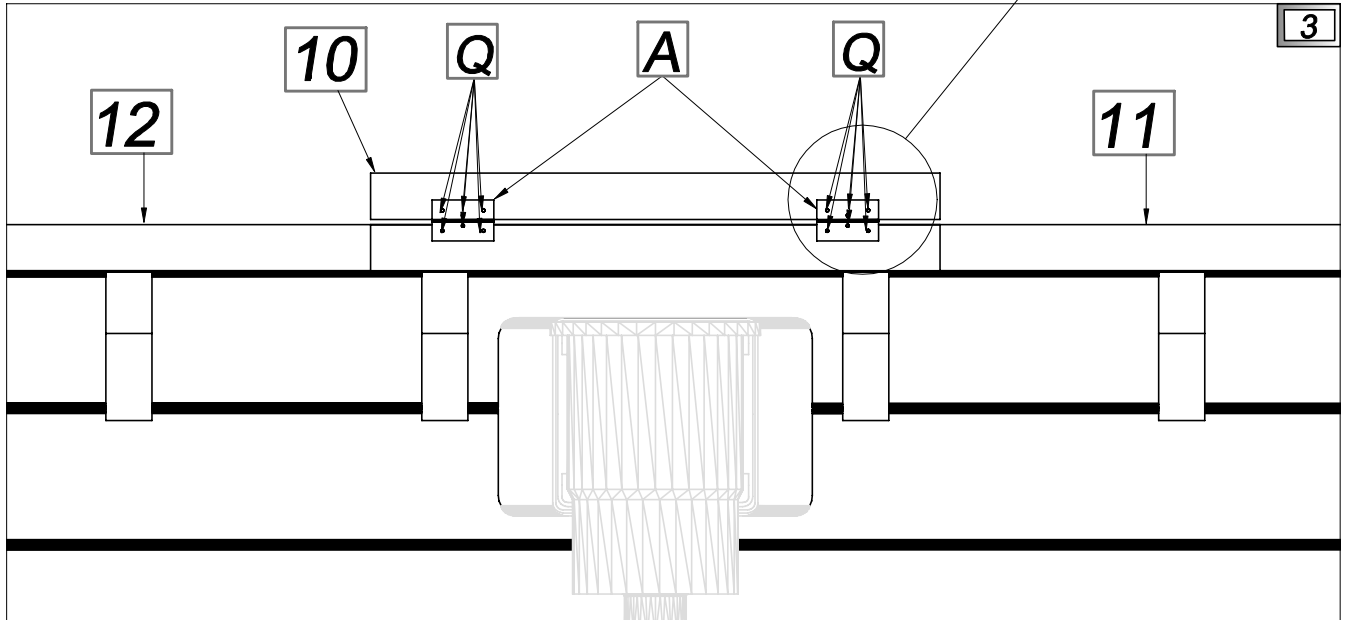
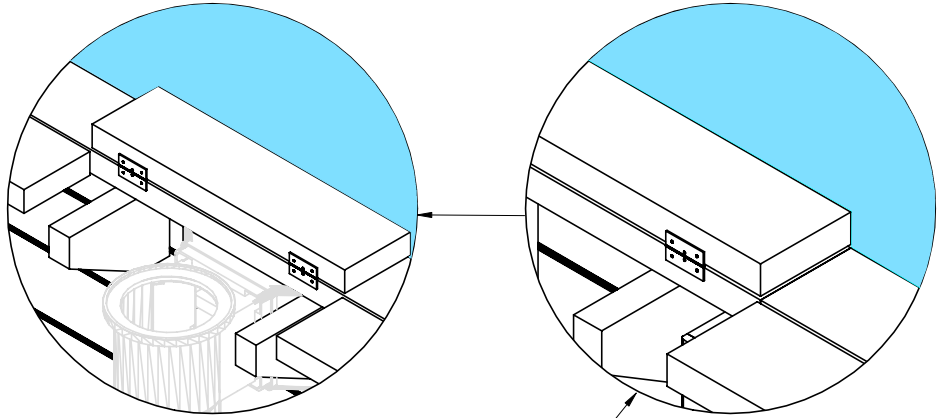
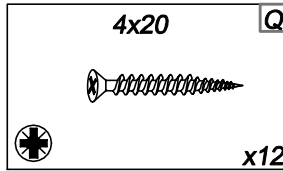
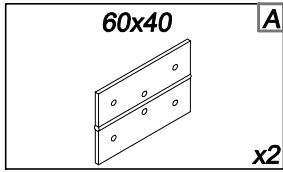



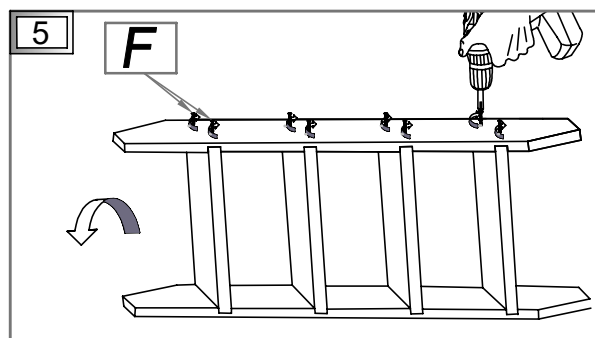
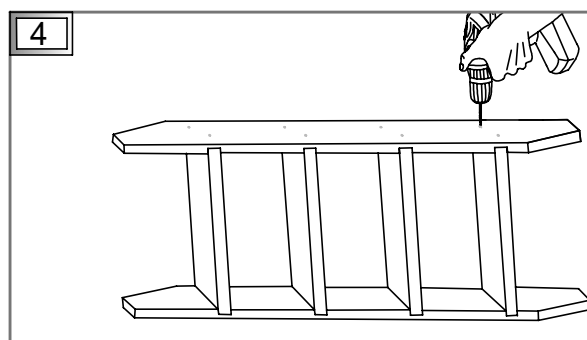
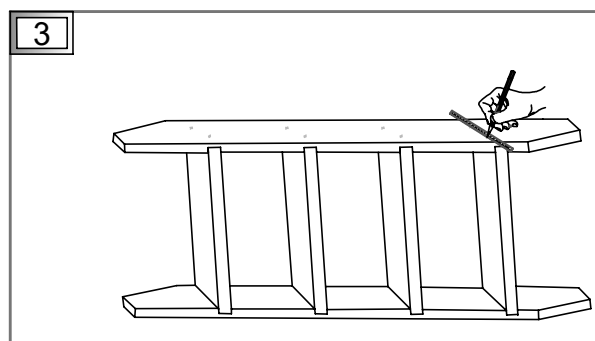
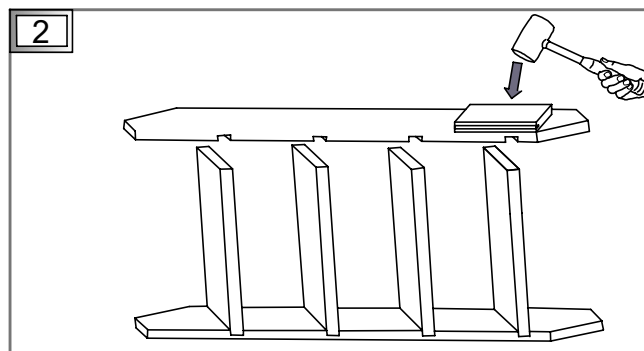
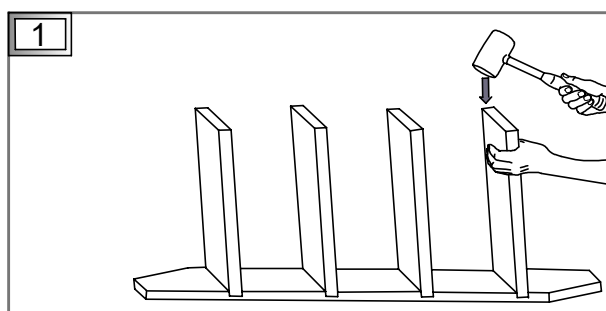
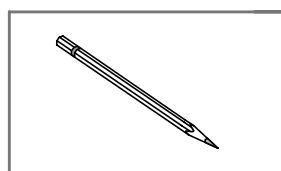
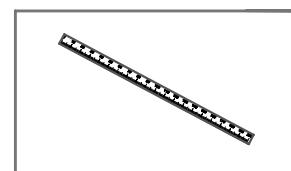
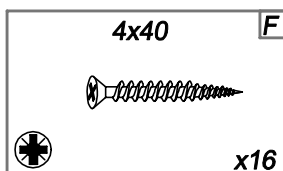
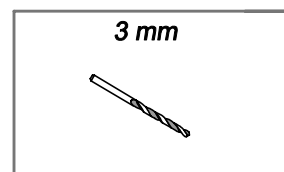
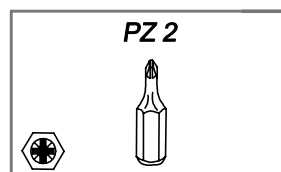
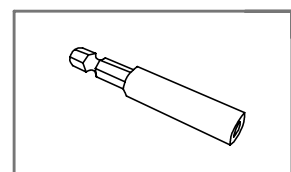
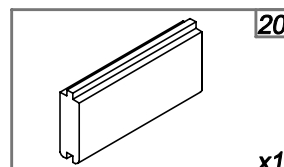
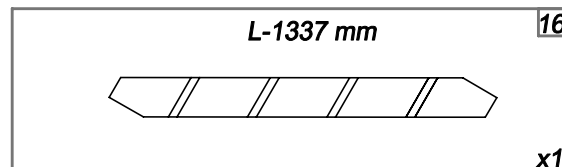
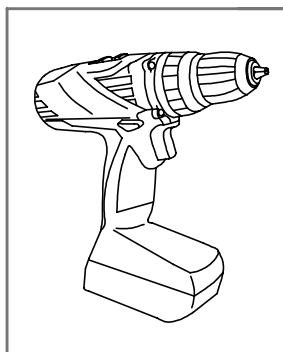
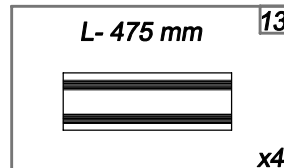
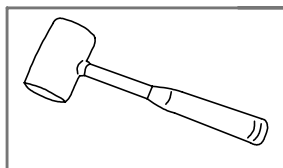

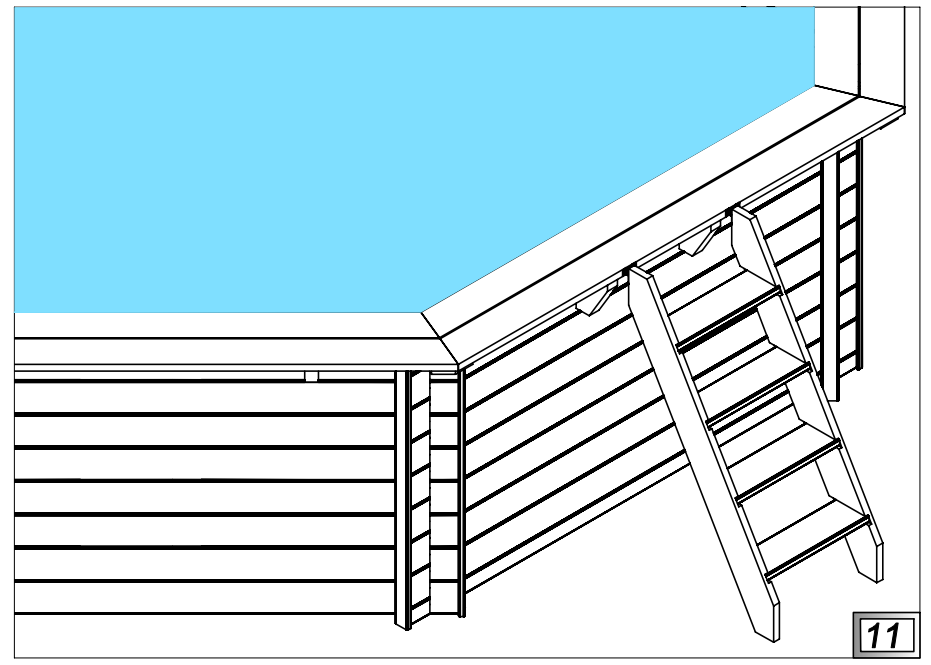
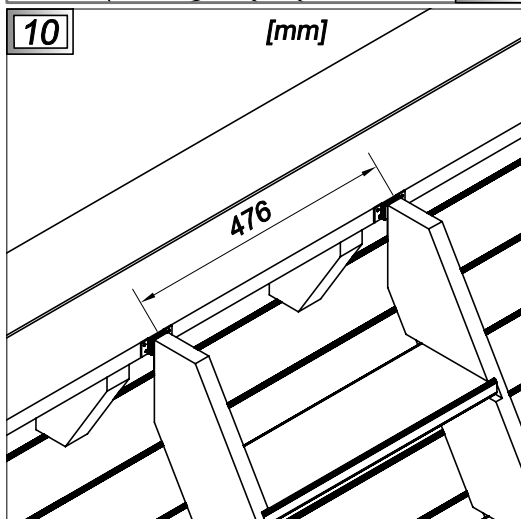
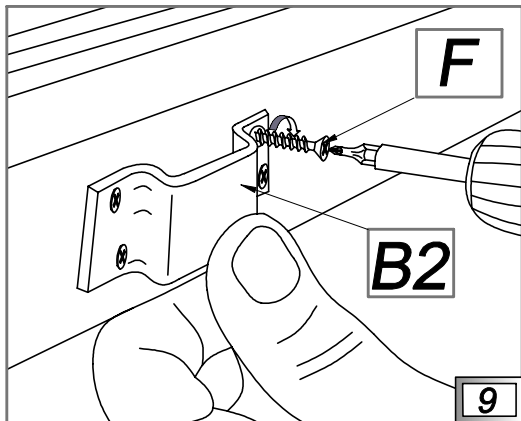
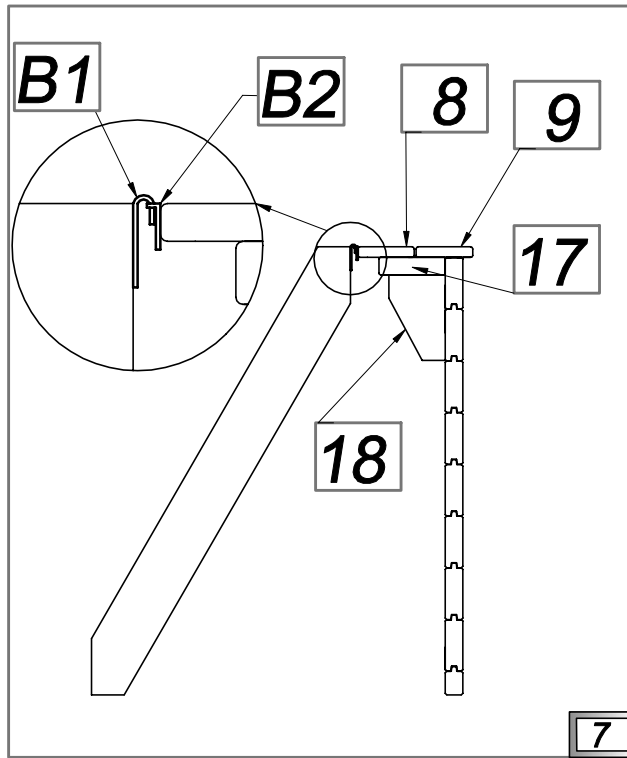
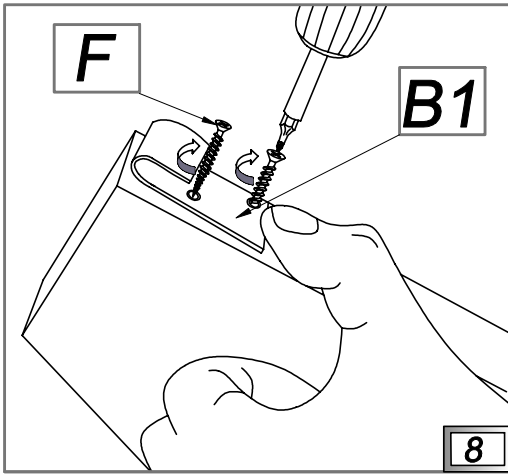
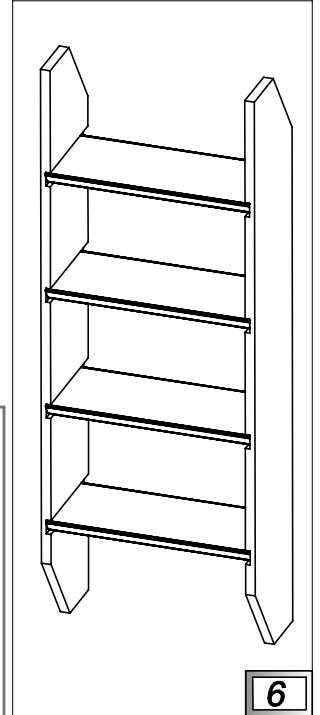
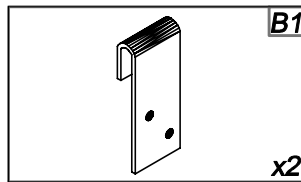
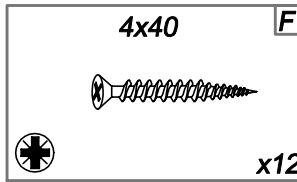
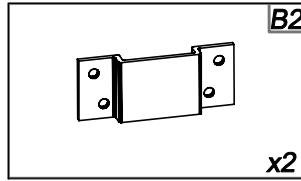
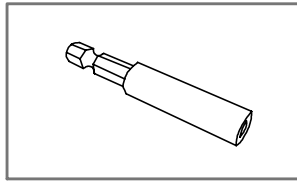
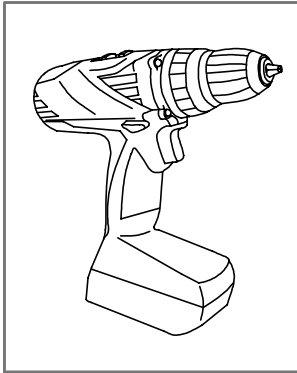

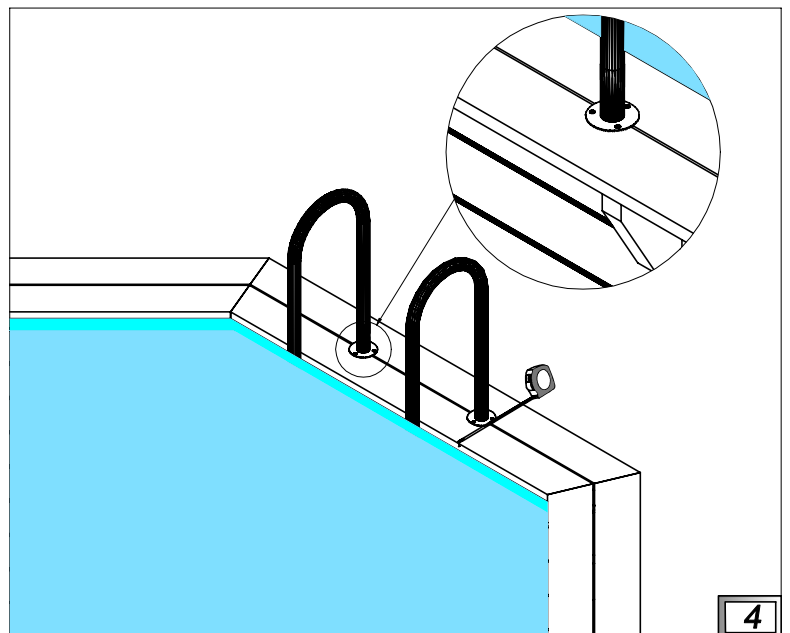
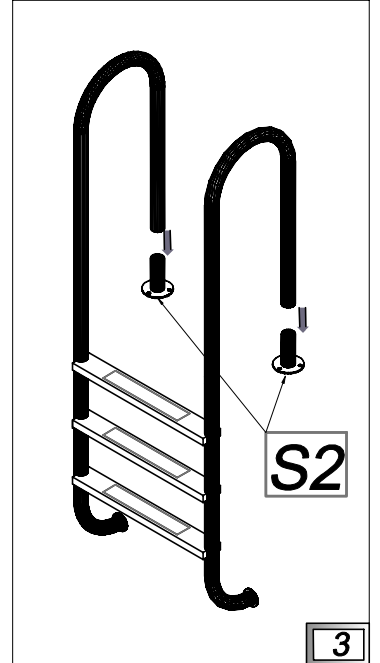
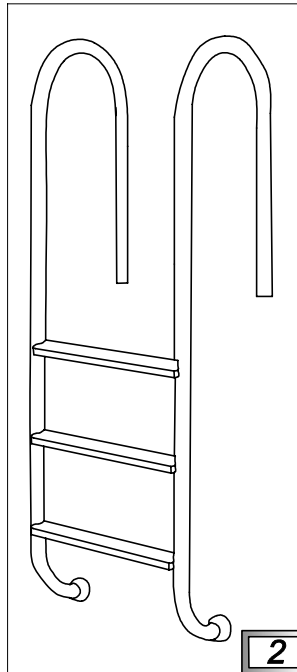
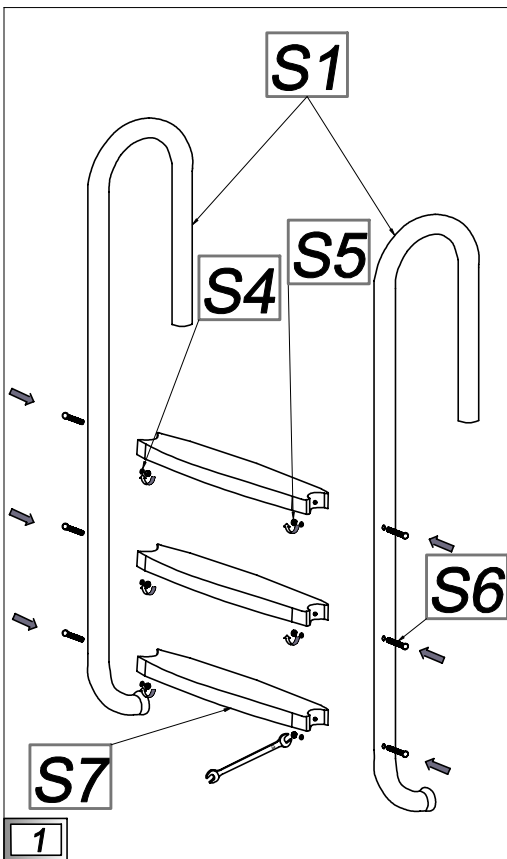
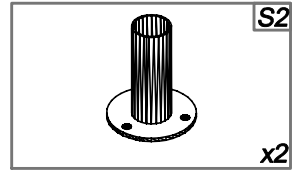
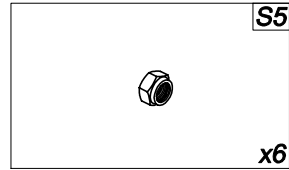
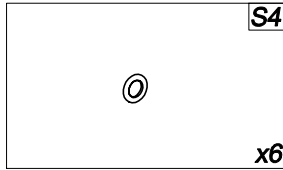
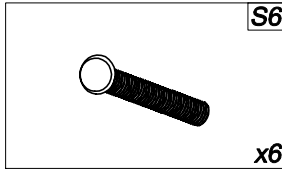
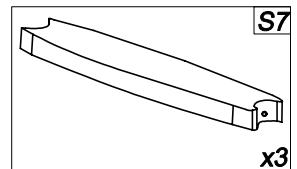
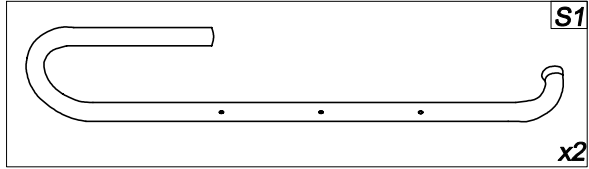
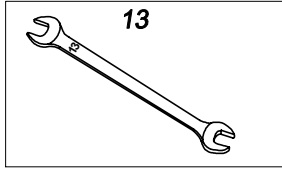

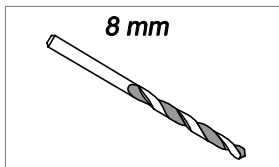
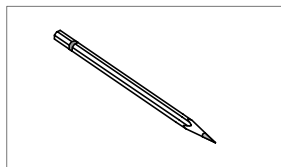
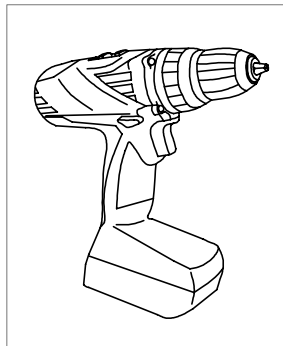

8 mm

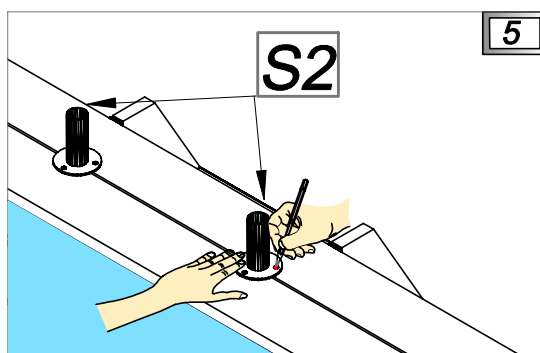

5

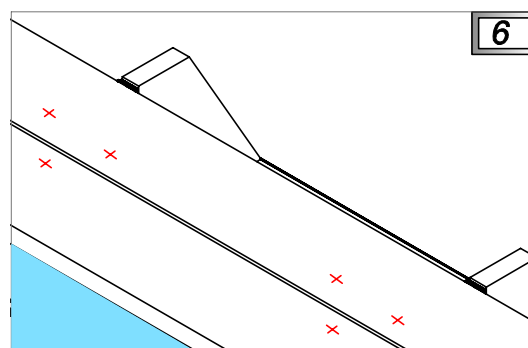

6

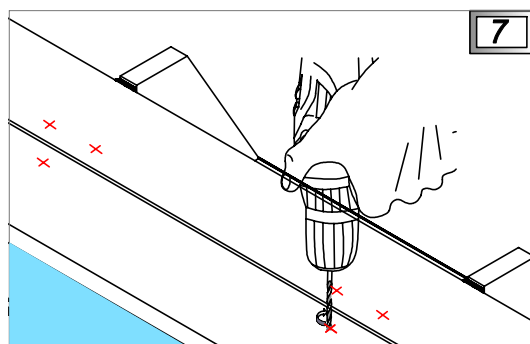

7

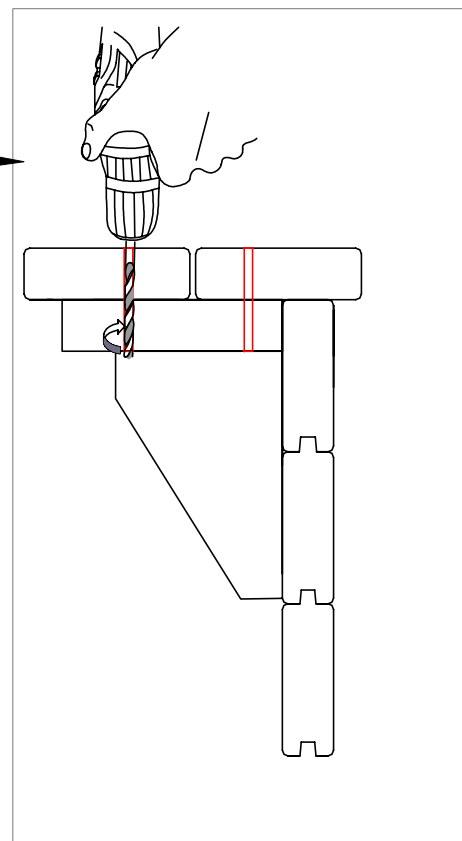

**PL** Otwór wykonać na przelot w celu wprowadzenie okucia S8

**GB** Make a hole through boards to put in the fittings S8

**PL** Drabinka stalowa

**GB** Stainless steel ladder

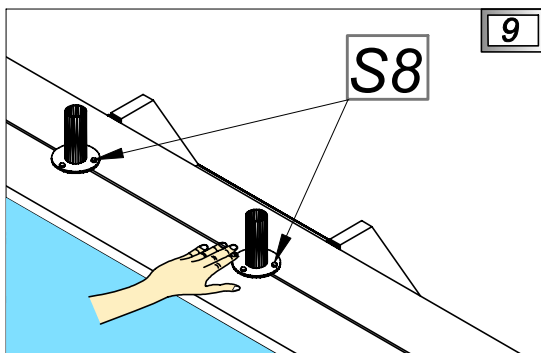
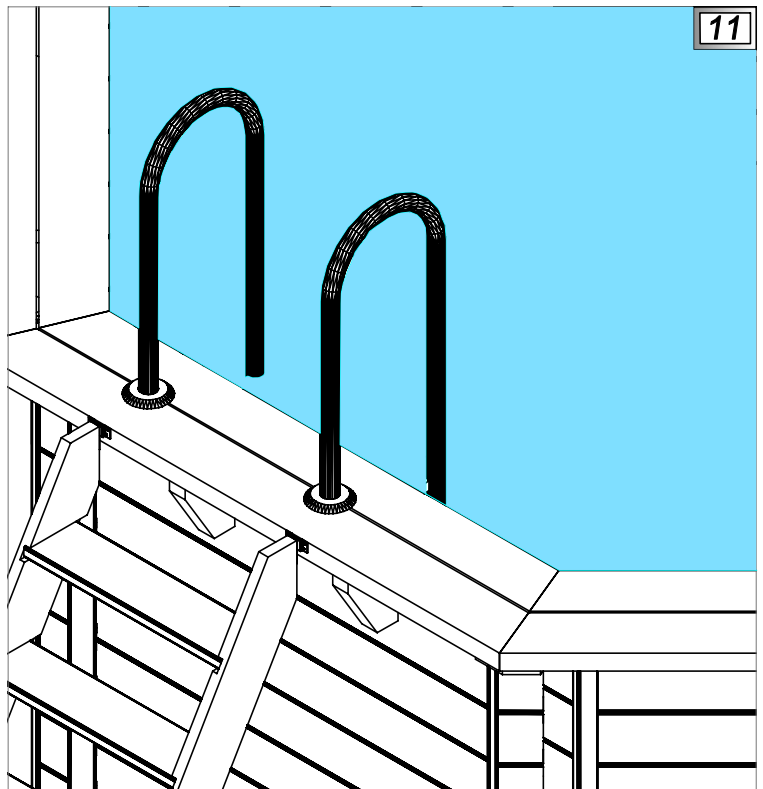
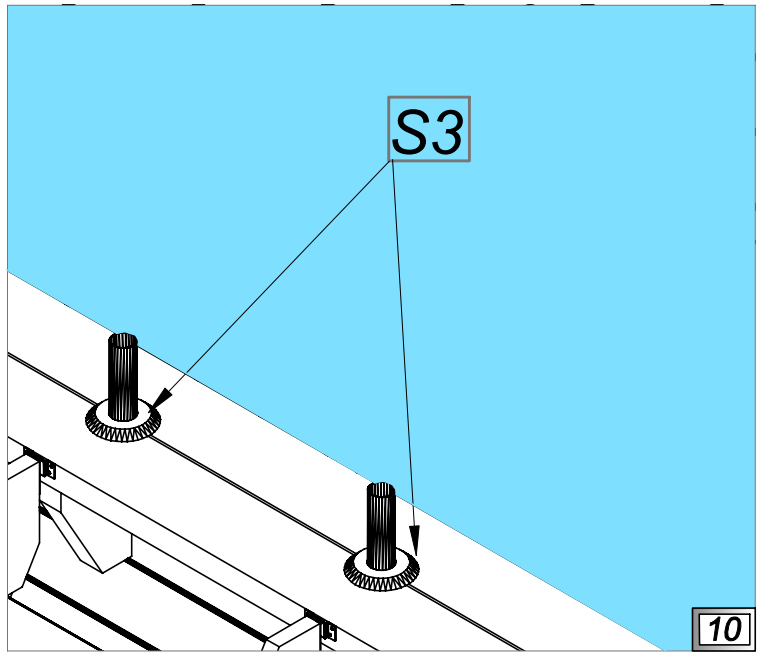
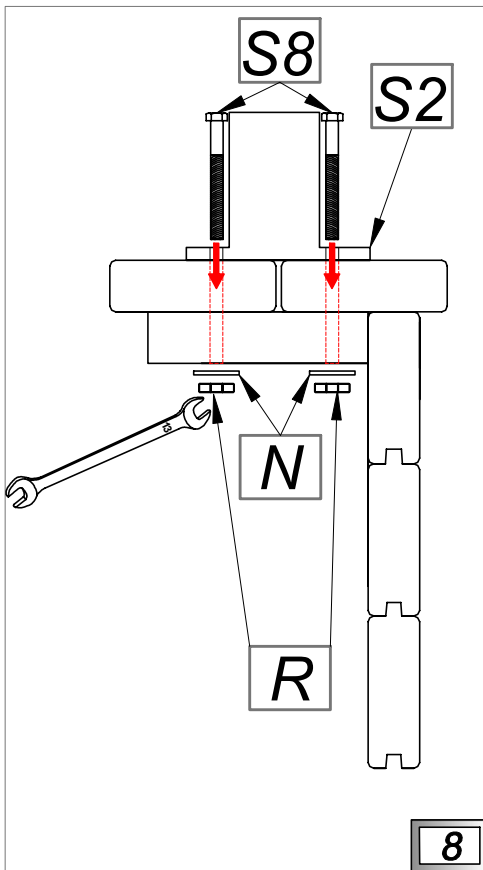
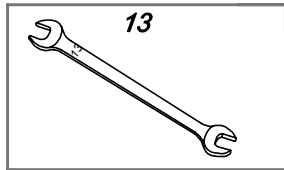
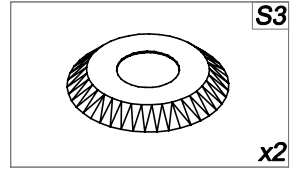
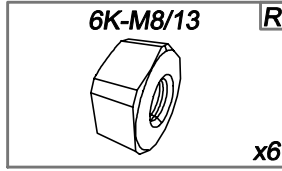
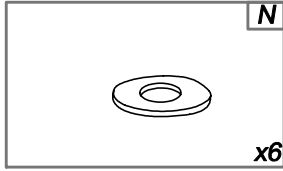
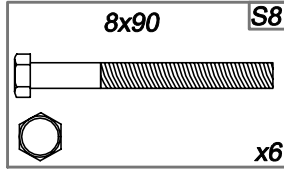

PL Maskownice

GB Corners covers

