

LIGHT STRING

Commercial Grade E26 Interconnectable Kits

Commercial E26 Medium base stringers are perfect for any outdoor patio or lighting display. Commercial grade stringers are weather resistant and designed for long term usage. Includes guy-wire loop for additional support for large spans or spaces. E26 base sockets are perfect for any standard LED or incandescent bulbs giving you the creative freedom for your lighting display.

- Great decorative lighting product for patios, gazebos, building outlines, event tents, and retail walkways
- Factory-molded, formulated PVC sockets on heavy-duty wire form a tight weather resistant seal around bulbs
- Suitable for outdoor commercial applications
- E26 Medium base decorative bulbs sold separately
- cTUVus Listed



LS2 SERIES QUICK SPECS

SERIES	LS2-M
INPUT VOLTAGE	120V AC
WATTAGE	25W per socket
MAX RUN	1200W
CABLE TYPE	14AWG SJTW 2-Wire
SOCKET TYPE	E26
SOCKET SPACING	24"
CUT INCREMENTS	Field cuttable (Must be properly sealed)
IP RATING	IP64 - Wet Location
RATING	cTUVus Listed

LS2 interconnect-able kits are cTUVus Listed to UL standard UL588 for wet location all-year use, however safety rating is void if product is cut. Not intended for installation in ceilings, soffits, cabinets or other enclosed spaces.
Keep lamps at least 4.9m/16ft away from pools and spas.

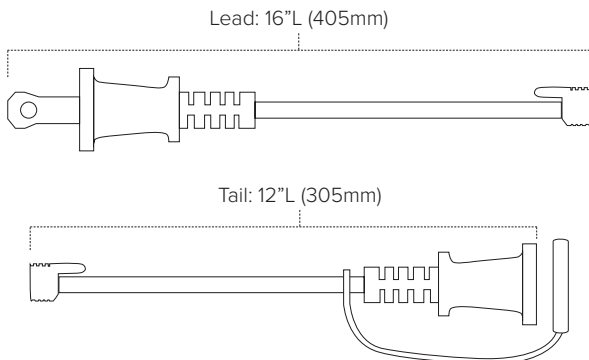

PROJECT: _____

TYPE: _____

LOCATION: _____

CATALOG NUMBER: _____



LS2 SERIES QUICK DIMENSIONS

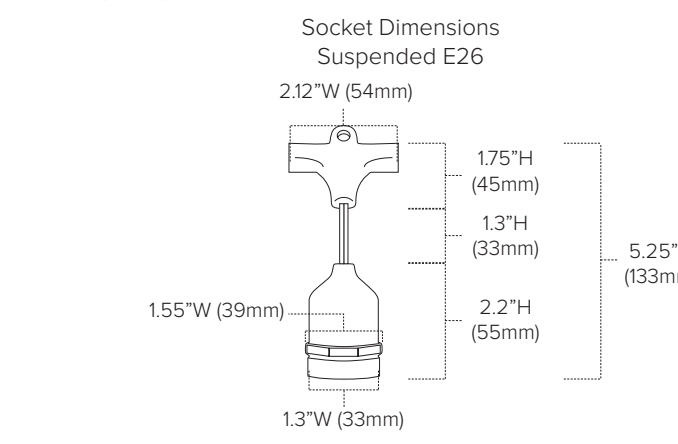
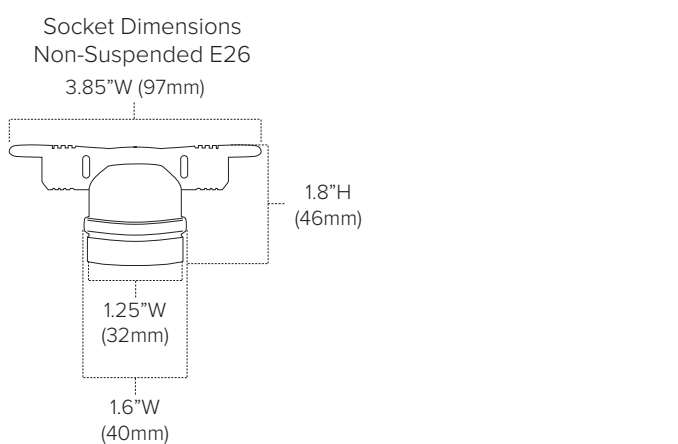

LS2 SERIES ORDERING INFORMATION

ITEM NUMBER	VOLTAGE	LENGTH	SOCKET TYPE	LED SPACING	COLOR	MAX RUN	IP RATING
LS2-M-24-48-BK	120V AC	48ft (15m)	Non-Suspended E26	24"	Black	25W/Socket / 1200W Interconnected	IP64
LS2-MNS-24-48-BK	120V AC	48ft (15m)	Non-Suspended E26	24"	Black	25W/Socket / 1200W Interconnected	IP64
LS2-MS-24-48-BK	120V AC	48ft (15m)	Suspended E26	24"	Black	25W/Socket / 1200W Interconnected	IP64
LS2-MS-24-48-WH	120V AC	48ft (15m)	Suspended E26	24"	White	25W/Socket / 1200W Interconnected	IP64

Includes: (1) 48ft length of LS2 series commercial grade light string with 120V plug and 120V socket (interconnectable male/female ends)

LS2 ACCESSORIES

ITEM NUMBER	DESCRIPTION
LS-SHADE-CLAS-7	25 Shades for LS2-MS & LS2-MNS Light String, 1.77in H x 7.44in Dia. Black Finish Exterior, White Finish Interior
LS-SHADE-DLX-6	25 Shades for LS2-MS & LS2-MNS Light String, 1.77in H x 6in Dia. Black Finish Exterior, White Finish Interior
LS-M/MS-END	Black plastic end cap
COMPATIBLE LAMPS	Pro Decorative Series, Standard S14s
LS-CABLE-60	60ft Catenary Cable Kit
LS-CABLE-110	110ft Catenary Cable Kit
LS-CABLE-500	500ft Catenary Cable Bulk Reel Includes
LS-LOCK-4	(4) Heavy duty cable locks for 1/8" catenary cable
LS-TT	Tensioning Tool

Catenary Cable Kit Includes: (1) 1/8" diameter catenary/guide cable for light string installation, (2) Heavy duty cable locks, and (1) Cable release key



ADDITIONAL INFORMATION

SUSPENDING LIGHT STRINGS:

Light sockets must be suspended so that bulbs are facing down only. **DO NOT MOUNT THE LIGHT STRINGS WITH SOCKETS FACING UPWARD!**

1. Light string must be securely attached to a support structure at each end of each span. The maximum unsupported span distance for 48' Cord & Plug Light String is 20 feet (10 sockets).
2. Secure light string to supporting hardware (eyebolts, brackets, etc., not provided) using cable ties (not included). See Figure 1.
3. Ensure any cut ends are properly sealed to preclude the entrance of water.
4. For spans exceeding 20 feet, use properly rated cable support system and cable ties (neither are provided with the light string) and follow local codes for suspended cables and loads. See www.americanlighting.com for steel cable support systems, if needed.

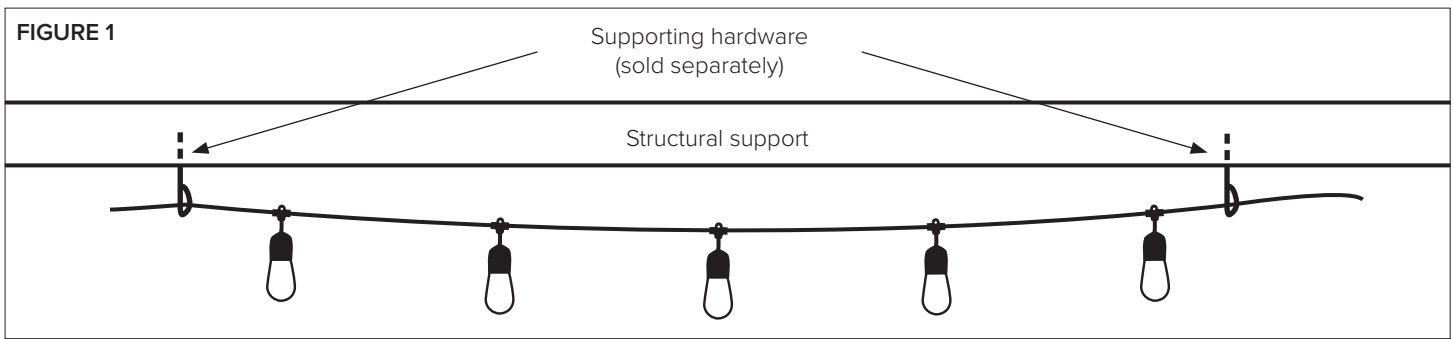



AMERICAN LIGHTING WARRANTY

LIMITED WARRANTY FOR LED PRODUCTS: 1 YEAR

LIMITED PRODUCT WARRANTY

Our products are warranted to be free from defects in material and workmanship for the warranty period listed. Warranty periods begin from the date of shipment from American Lighting Inc's warehouse to the original purchaser. Products that prove to be defective during their specific warranty period will be either repaired or replaced, at the sole discretion of American Lighting Inc. Claims for defective products must be submitted in writing to American Lighting Inc's RGA Department within the warranty period. Upon approval of such return, American Lighting Inc reserves the right to inspect the product for misuse or abuse. Claims for indirect or consequential damages or for product that, in American Lighting Inc's opinion, has been misused will be denied. This is a warranty of product reliability only and not a warranty of merchantability or fitness for a particular purpose. American Lighting Inc shall have no liability whatsoever in any event for payment of incidental or consequential damages, including, without limitations, installation costs and/or damages for personal injury and/or property. These products may represent a possible shock or fire hazard if improperly installed or altered in any way. This warranty does not apply to any product that has not been properly installed in accordance with current local codes and/or the National Electrical Code. Products that require a transformer, driver, or power supply must be used in conjunction with American Lighting Inc's recommended power supply to ensure safety and retain product warranty.

PRODUCT SPECIFICATIONS

For the latest product information, updates, instructions and details concerning specifications, colors, finishes, performance, installation and design, visit www.americanlighting.com. Color may vary from the color printed herein due to limitations in photographic and printing processes. American Lighting Inc. reserves the right to change product specifications without notice. Other product specifications such as color temperature, wavelength characteristics and lumen output are subject to production limitations and may vary. LED technology is changing rapidly, and not all color temperatures and performance levels can be duplicated at a later time. Best practices include purchasing 10-15% more for a particular project on the same initial order where white LED color temperatures must be maintained over project and product life. Eventual product replacement should be considered at layout and design stages. Best practices also include testing connections and product performance prior to mounting and/or installing.

AVERAGE LIFE

Average incandescent lamp life, rated life and average life are terms used to describe the number of hours at which half of the lamps have failed. For LEDs, the hours of rated life specify the point where 70% of original lumen output is reached. Below this point, the effective life is over, however, the LED may still emit light. Individual results may vary with actual environmental conditions including, but not limited to, proper installation, ambient temperature and/or input voltage fluctuations.