



Certified to NSF/ANSI/CAN 50



# VINYL/FIBERGLASS FLOWSTAR® SKIMMERS

PUBLIC & RESIDENTIAL INSTALLATION, OPERATION & PARTS

Float valve is not NSF certified.

IMPORTANT SAFETY INSTRUCTIONS FOR SKRVFL3Nxxx, SKRVFL3Nxxx-L, SKRVFL18xxx, SKRVFL18xxx-L, SKR35xxx, SKR35xxx-L, SKR35xxx-B-L, SKR35xxx-B, SKR36xxx, SKR36xxx-L, SKR36Bxxx, SKR36xxx-L

**Max Flow**  
2½" Pipe: 90 GPM  
2" Pipe : 63 GPM

**Min Flow**  
2½" Pipe: 15 GPM  
2" Pipe : 15 GPM

**READ AND FOLLOW ALL INSTRUCTIONS**

## ⚠ WARNING!

**HAZARDOUS SUCTION. RISK OF HAIR OR BODY ENTRAPMENT, DROWNING OR DISEMBOWELMENT.** When an equalizer is used, the opening in the pool shall be protected by a VGBA Compliant drain cover rated for 100 GPM or greater. NOTE: Skimmer is not equivalent to a main drain. If not using a single, unblockable drain, all pools, spas and hot tubs must have at least two main drains besides skimmer(s) or a "single, unblockable" drain.

**SAVE THESE INSTRUCTIONS FOR FUTURE REFERENCE**

## OPERATION

### Operation Overview

Pump suction pulls water through skimmer. Water flowing into skimmer carries floating leaves, bugs, etc., where they are trapped in the skimmer basket. Dust, body oils, etc., pass through the basket to be removed by the filter. Weir door in skimmer opening enhances surface flow and skimming action.

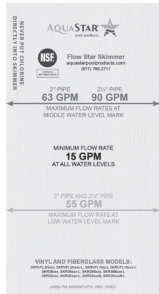

Figure 1:  
Data Plate Image

### Water Level

Keep pool, spa or hot tub water level at the middle water level mark, on the data plate image located inside skimmer housing, for best performance. Never operate below the low mark, see Figure 1.

### Flow Adjustments

Adjust valves located before the pump, see Figure 2.

### Vacuuming Pool

Remove deck lid and skimmer basket. If there is a float valve, remove it and plug equalizer port that is closest to the pool. Replace basket and place vacuum plate on top of basket. Fill the vacuum hose with water and then place your hand over the end of the hose as you bring it through the skimmer throat, or over the deck to attach it to the vacuum plate (Figure 3). Follow instructions in vacuum owner's manual for vacuuming operation. After vacuuming, remove hose, vacuum plate and basket, unplug equalizer port and reinstall float valve, basket and deck lid.

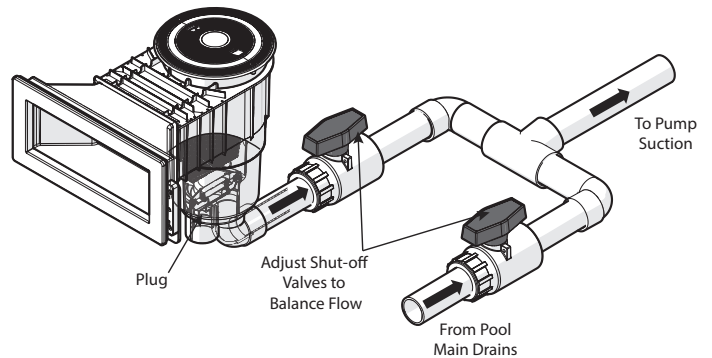

Figure 2: Typical residential installation

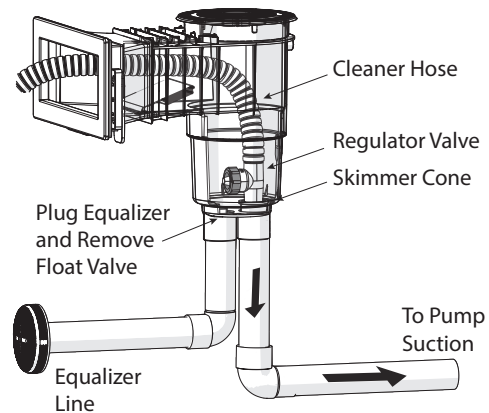

Figure 3: Vacuuming pool; float and check valves removed, equalizer port plugged.

## MAINTENANCE

Periodically check weir for free operation. Replace if damaged or worn. Check strainer basket as often as needed for accumulated leaves, debris, etc. Empty basket as required.

Skimmer deck lid is made of impact and weather resistant materials, but extended use (5-10 years) may lead to reduced strength. Regularly check condition of skimmer lid. Look for cracks, chips, deterioration of plastic, etc. If any sign of damage or deterioration is found, replace the deck lid and fasteners.

To winterizing, drain pool until level is below skimmer inlet. Remove cover, basket and float. Plug bottom port(s). Cover skimmer to prevent rainwater or snow from entering the skimmer where it could freeze.

### **WARNING! LOW WATER LEVEL CAN MAKE IT DIFFICULT TO EXIT POOL AND MAY DAMAGE PUMP AND OTHER POOL EQUIPMENT.**

Note: An equalizer line is a way to bypass the skimmer and it is intended to inhibit damage to the pump when pool water level is below the throat of the skimmer or the basket is full. You must check your local code as some require equalizer lines, others don't allow them and others leave it to the pool designer. When equalizer line is used the cover inside the pool must be VGBA compliant, and have a flow rating higher than the skimmer's configuration-specific flow rating.

## SKIMMER LAYOUT AND SUCTION LINE SIZING

Skimmers are critically important for removing floating contaminants, oils, and debris; for this reason modern pool building codes require that the number of skimmers installed are capable of handling 100% of the filtration flow rate.

1. The minimum number of skimmers needed is based on facility type (See Table 1).
2. When selecting the location for skimmers, at least one should be placed so that the prevailing wind blows towards the skimmer.
3. Size suction pipe based on the design flow rate such that the water velocity in the pipe will not exceed six feet per second. To increase system flow capacity for long pipe runs, use multiple pipes (both ports) or larger pipe (2.5" spigot, or 3"/4" adapter bushing #BFB101). See figures 5 and 7 piping layout.

Table 1: Skimmers Required Per Square Foot Area

Facility Type	Area Per Skimmer (sq. ft.)
Public Pool	500
Residential Pool	800
Public and Residential Spa	150

Example: A public pool that is 1000 sq. ft. requires at least two skimmers.

## INSTALLATION

Skimmer installation details, including concrete and steel requirements, are project-specific. AquaStar does not determine site-specific installation requirements. See section "Dimensions and Parts List", "Face Plate Dimensions", and "Face Installation Instructions" for basic dimensions and further instructions. Top cover frame has 1" vertical height adjustment.

### **PIPE CONNECTIONS AND TESTING**

Connect pump inlet line to rear port in bottom manifold. Skimmer manifold is PVC, and comes in a variety of configurations. For threaded connections inside skimmer manifold, do not use pipe dope; to seal joint use RTV Silastic #732 (preferred), Teflon tape or Plasto-Joint Stik. For slip connections, use a temperature-appropriate PVC solvent cement and primer on both the pipe and the fitting. Ensure all surfaces are clean and free of debris before application. Consider ambient temperature and humidity during installation, as these factors can affect the curing process. Apply the primer to both the pipe and the fitting, followed by the solvent cement. Assemble the joint per the cement manufacturer's instructions, including rotating the pipe a quarter turn to evenly distribute the cement. Allow the joint to set for the recommended time before pressure testing to ensure a secure and leak-free connection.

**WARNING! PLASTIC CEMENTS AND PRIMERS CAN BE FLAMMABLE, POISONOUS OR BOTH. CLOSELY FOLLOW CEMENT MANUFACTURER'S INSTRUCTIONS.**

**WARNING! FALLING AND TRIPPING HAZARD. THE DECK LID MUST BE INSTALLED FLUSH WITH THE DECK LEVEL.**

**NOTE: THE SKIMMER FILL LINE CONNECTION IS MADE OF ABS MATERIAL. PLEASE USE THE APPROPRIATE TRANSITION GLUE FOR CONNECTING TO PVC PIPING TO ENSURE A SECURE AND LEAK-FREE INSTALLATION.**

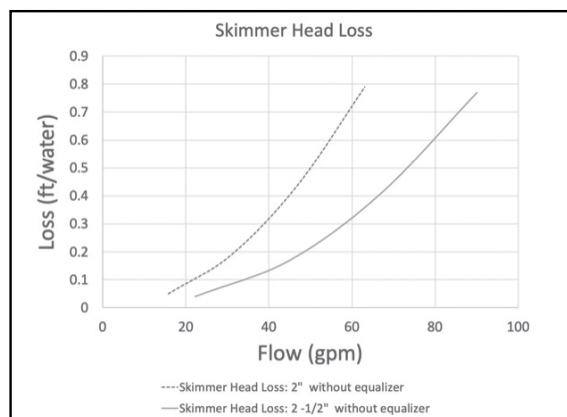

## DIMENSIONS AND PARTS LIST

### FlowStar® Skimmer with Narrow 9" Throat for Vinyl and Fiberglass

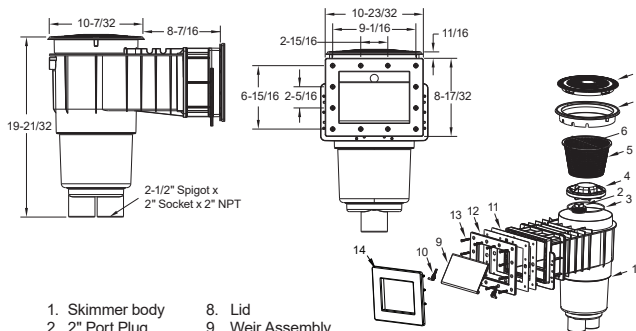

- |                   |  |
|-------------------|--|
| 1. Skimmer body   | 8. Lid   |
| 2. 2" Port Plug   | 9. Weir Assembly                                   |
| 3. O-Ring         | 10. Weir Clip, Qty 2                               |
| 4. Float Assembly | 11. Gasket, Extender 9" And 12", Qty 2             |
| 5. Basket         | 12. Face Frame, Extender 9" And 12"                |
| 6. Skimmer Rod    | 13. 12 x 1-3/4" Flat Head Phillips, 316 SS, Qty 12 |
| 7. Collar         | 14. Decorative Cover                               |

Part # SKRVFL3Nxxx

#### Part Numbers/Colors

- SKRVFL3N101 - White
- SKRVFL3N102 - Black
- SKRVFL3N103 - Lt. Gray
- SKRVFL3N105 - Dk. Gray
- SKRVFL3N108 - Tan

Float valve is not NSF certified.

### FlowStar® Skimmer with Narrow 9" Throat and 9" Ultra Basket for Vinyl and Fiberglass (Optional Water Bond)

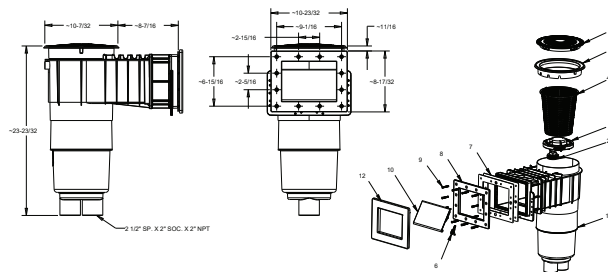

- |                            |   |
|----------------------------|---|
| 1. Deep Skimmer Body       | 7. Gasket Extender 9" And 12", Qty 2              |
| 2. 2" NPT Port Plug        | 8. Face Frame, Extender 9" And 12"                |
| 3. Float Assembly          | 9. 12 x 1-1/4" Flat Head Phillips, 316 SS, Qty 12 |
| 4. 9" Ultra Skimmer Basket | 10. Weir Door Assembly                            |
| 5. Skimmer Collar          | 11. Weir Door Clips                               |
| 6. Skimmer Lid             | 12. Decorative Cover                              |

Part # SKRVFL3Nxxx-L/  
SKRVFL18xxx-L (Bonded)

#### Part Numbers/Colors

- SKRVFL3N101-L - White
- SKRVFL3N102-L - Black
- SKRVFL3N103-L - Lt. Gray
- SKRVFL3N105-L - Dk. Gray
- SKRVFL3N108-L - Tan

Float valve is not NSF certified.

### FlowStar® Skimmer with Narrow 9" Throat and Water Bond for Vinyl and Fiberglass

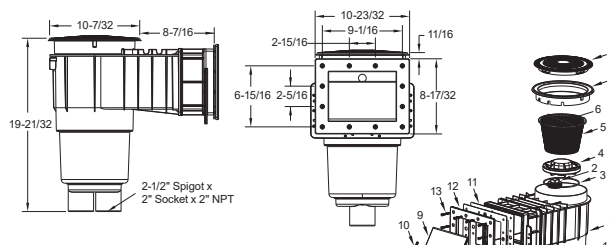
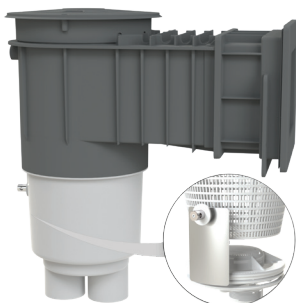

- |                       |  |
|-----------------------|--|
| 1. Skimmer body       | 9. Weir Assembly                                   |
| 2. 2" Port Plug       | 10. Weir Clip, Qty 2                               |
| 3. O-Ring             | 11. Gasket, Extender 9" And 12", Qty 2             |
| 4. Float Assembly     | 12. Face Frame, Extender 9" And 12"                |
| 5. Basket             | 13. 12 x 1-1/4" Flat Head Phillips, 316 SS, Qty 12 |
| 6. Skimmer Basket Rod | 14. Bonding Plate Assembly                         |
| 7. Collar             | 15. Decorative Cover                               |
| 8. Lid                |  |

Part # SKRVFL18xxx

#### Part Numbers/Colors

- SKRVFL18101B - White
- SKRVFL18102B - Black
- SKRVFL18103B - Lt. Gray
- SKRVFL18105B - Dk. Gray
- SKRVFL18108B - Tan

Float valve is not NSF certified.

## DIMENSIONS AND PARTS LIST

### FlowStar® Skimmer with 7 Degree Angle for Fiberglass

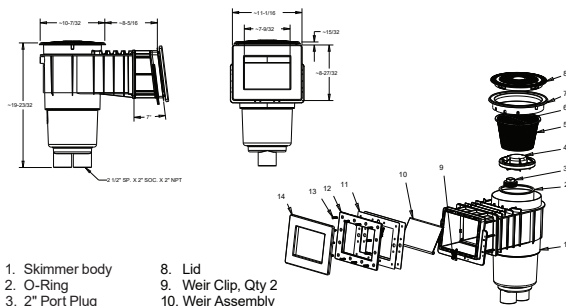

- |                   |   |
|-------------------|---|
| 1. Skimmer body   | 8. Lid                                    |
| 2. O-Ring         | 9. Weir Clip, Qty 2                       |
| 3. 2" Port Plug   | 10. Weir Assembly                         |
| 4. Float Assembly | 11. Gasket, Qty 2                         |
| 5. Basket         | 12. Face Frame                            |
| 6. Basket Rod     | 13. 1" Flat Head Phillips, 316 SS, Qty 12 |
| 7. Collar         | 14. Decorative Cover                      |

Part # SKR35xxx

#### Part Numbers/Colors

- SKR35101 - White
- SKR35102 - Black
- SKR35103 - Lt. Gray
- SKR35105 - Dk. Gray
- SKR35108 - Tan

Float valve is not NSF certified.

### FlowStar® Skimmer with 7 Degree Angle for Fiberglass with 9" Ultra Basket

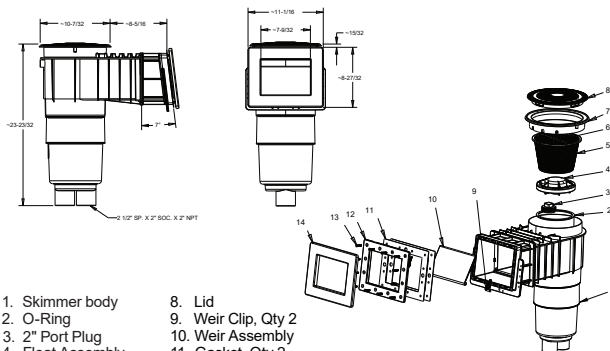

- |                   |   |
|-------------------|---|
| 1. Skimmer body   | 8. Lid                                    |
| 2. O-Ring         | 9. Weir Clip, Qty 2                       |
| 3. 2" Port Plug   | 10. Weir Assembly                         |
| 4. Float Assembly | 11. Gasket, Qty 2                         |
| 5. Basket         | 12. Face Frame                            |
| 6. Basket Rod     | 13. 1" Flat Head Phillips, 316 SS, Qty 12 |
| 7. Collar         | 14. Decorative Cover                      |

Part # SKR35xxx-L/  
SKR35xxxB-L (Bonded)

#### Part Numbers/Colors

- SKR35101-L - White
- SKR35102-L - Black
- SKR35103-L - Lt. Gray
- SKR35105-L - Dk. Gray
- SKR35108-L - Tan

Float valve is not NSF certified.

### FlowStar® Skimmer with 7 Degree Angle for Fiberglass with Water Bond

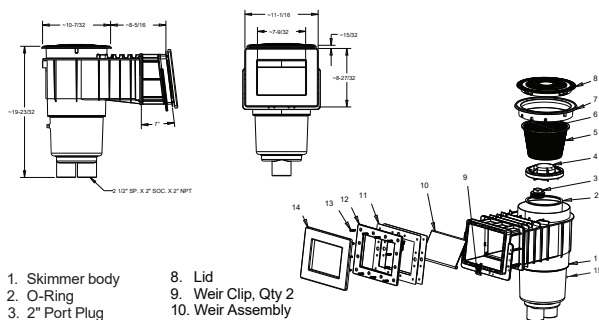

- |                   |   |
|-------------------|---|
| 1. Skimmer body   | 8. Lid                                    |
| 2. O-Ring         | 9. Weir Clip, Qty 2                       |
| 3. 2" Port Plug   | 10. Weir Assembly                         |
| 4. Float Assembly | 11. Gasket, Qty 2                         |
| 5. Basket         | 12. Face Frame                            |
| 6. Basket Rod     | 13. 1" Flat Head Phillips, 316 SS, Qty 12 |
| 7. Collar         | 14. Decorative Cover                      |
|                   | 15. Bonding Plate Assembly                |

Part # SKR35xxxB

#### Part Numbers/Colors

- SKR35101B - White
- SKR35102B - Black
- SKR35103B - Lt. Gray
- SKR35105B - Dk. Gray
- SKR35108B - Tan

Float valve is not NSF certified.

## DIMENSIONS AND PARTS LIST

### FlowStar® Wide Mouth Skimmer for Fiberglass and Vinyl

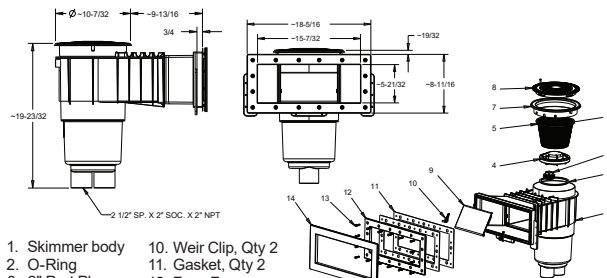
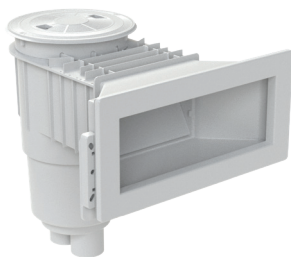

- |                   |  |
|-------------------|--|
| 1. Skimmer body   | 10. Weir Clip, Qty 2                               |
| 2. O-Ring         | 11. Gasket, Qty 2                                  |
| 3. 2" Port Plug   | 12. Face Frame                                     |
| 4. Float Assembly | 13. 12 x 1-1/4" Flat Head Phillips, 316 SS, Qty 16 |
| 5. Basket         | 14. Decorative Cover                               |
| 6. Basket Rod     | <i>Also Included</i>                               |
| 7. Collar         | 15. 12 x 1-1/2" Pan Head Phillips, 316 SS, Qty 4   |
| 8. Lid            | 16. 12 x 5/8" Pan Head Phillips, 316 SS, Qty 4     |
| 9. Weir Assembly  | 17. Easy Clip Spacer, Qty 3                        |

Part # SKR36xxx

#### Part Numbers/Colors

- SKR36101 - White
- SKR36102 - Black
- SKR36103 - Lt. Gray
- SKR36105 - Dk. Gray
- SKR36108 - Tan

Float valve is not NSF certified.

### FlowStar® Wide Mouth Skimmer and 9" Ultra Basket for Fiberglass and Vinyl (Optional Water Bond)

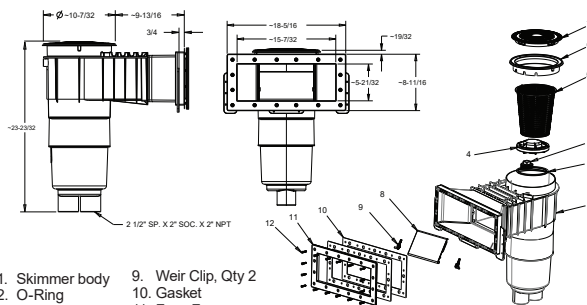

- |                    |  |
|--------------------|--|
| 1. Skimmer body    | 9. Weir Clip, Qty 2                                |
| 2. O-Ring          | 10. Gasket   |
| 3. 2" Port Plug    | 11. Face Frame                                     |
| 4. Float Assembly  | 12. 12 x 1-1/4" Flat Head Phillips, 316 SS, Qty 16 |
| 5. 9" Ultra Basket | <i>Also Included</i>                               |
| 6. Collar          | 13. 5/8" Pan Head Phillips, 316 SS, Qty 4          |
| 7. Lid             | 14. 1-1/2" Flat Head Phillips, 316 SS, Qty 4       |
| 8. Weir Assembly   | 15. Decorative Cover                               |
|                    | 16. Easy Clip Spacer, Qty 3                        |

Part # SKR36xxx-L/  
SKR36xxxB-L (Bonded)

#### Part Numbers/Colors

- SKR36101-L - White
- SKR36102-L - Black
- SKR36103-L - Lt. Gray
- SKR36105-L - Dk. Gray
- SKR36108-L - Tan

Float valve is not NSF certified.

### FlowStar® Wide Mouth Skimmer and 9" Ultra Basket for Fiberglass and Vinyl and Water Bond

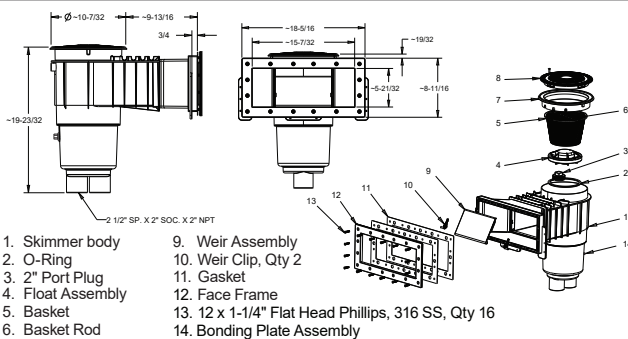
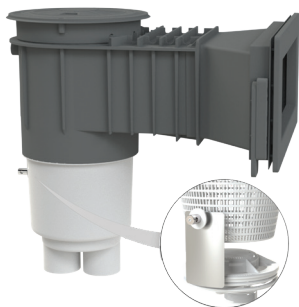

- |                   |  |
|-------------------|--|
| 1. Skimmer body   | 9. Weir Assembly                                   |
| 2. O-Ring         | 10. Weir Clip, Qty 2                               |
| 3. 2" Port Plug   | 11. Gasket   |
| 4. Float Assembly | 12. Face Frame                                     |
| 5. Basket         | 13. 12 x 1-1/4" Flat Head Phillips, 316 SS, Qty 16 |
| 6. Basket Rod     | 14. Bonding Plate Assembly                         |
| 7. Collar         | <i>Also Included</i>                               |
| 8. Lid            | 15. 5/8" Pan Head Phillips, 316 SS, Qty 4          |
|                   | 16. 1-1/2" Flat Head Phillips, 316 SS, Qty 4       |
|                   | 17. Decorative Cover                               |
|                   | 18. Easy Clip Spacer, Qty 3                        |

Part # SKR36Bxxx

#### Part Numbers/Colors

- SKR36B101 - White
- SKR36B102 - Black
- SKR36B103 - Lt. Gray
- SKR36B105 - Dk. Gray
- SKR36B108 - Tan

Float valve is not NSF certified.

## DIMENSIONS AND PARTS LIST *CONTINUED*

### Flow Star Skimmer with 9" Deep Throat, Float Assembly, Basket, Lid, Adjustable Collar For Fiberglass/Vinyl

Model # SKRFVL3Nxxx, SKRFVL3Nxxx-L, SKRVFL18xxx, SKRVFL18xxx-L

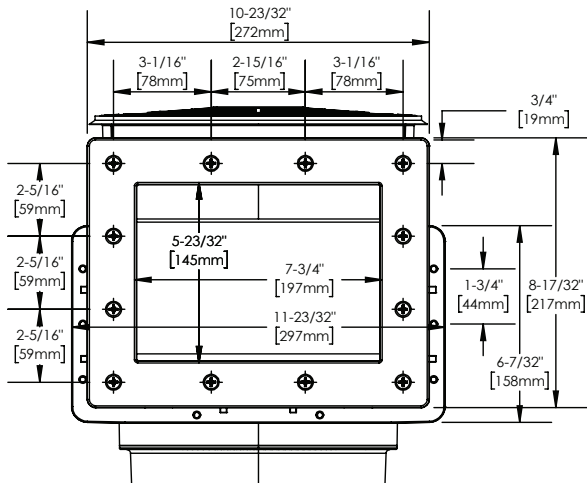

#### CUT OUT PANEL OTHER THAN WOOD

A - HEIGHT MIN 5-13/16" (148 mm) MAX 6-1/16" (154 mm)

B - WIDTH MIN 8" (203 mm) MAX 8-1/4" (210 mm)

#### CUT OUT PANEL FOR WOOD PANEL WITH VINYL LINER

A - HEIGHT MIN 7-11/16" (195 mm) MAX 7-7/8" (154 mm)

B - WIDTH MIN 9-7/8" (251 mm) MAX 10-1/8" (257 mm)

*DRILL or PUNCH 12 HOLES 1/4" DIAMETER AS SHOWN*

### Flow Star Skimmer with 7 Degree Angle, Float Assembly, Basket, Adjustable Collar For Fiberglass

Model # SKR35XXX, SKR35XXX-L, SKR35XXXB, SKR35XXXB-L

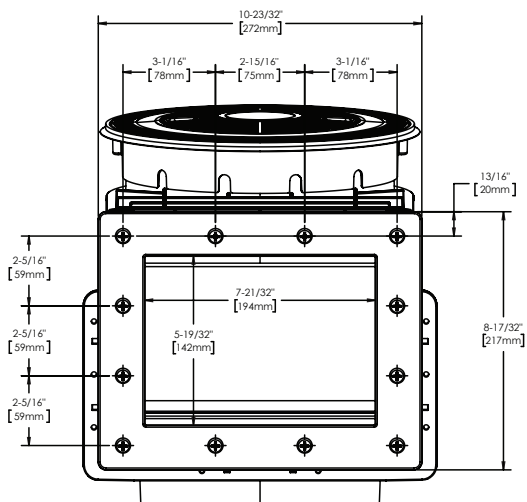

#### CUT OUT PANEL OTHER THAN WOOD

A - HEIGHT MIN 5-13/16" (148 mm) MAX 6-1/16" (154 mm)

B - WIDTH MIN 8" (203 mm) MAX 8-1/4" (210 mm)

#### CUT OUT PANEL FOR WOOD PANEL WITH VINYL LINER

A-HEIGHT MIN 7-11/16" (195 mm) MAX 7-7/8" (200 mm)

B-WIDTH MIN 9-7/8" (251 mm) MAX 10-1/8" (257 mm)

*DRILL or PUNCH 12 HOLES 1/4" DIAMETER AS SHOWN*

### Flow Star Wide Mouth Skimmer with 9" Deep Throat, Float Assembly, Basket, Lid, Adjustable Collar For Fiberglass/Vinyl

Model # SKR36xxx, SKR36xxx-L, SKR36Bxxx, SKR36Bxxx-L

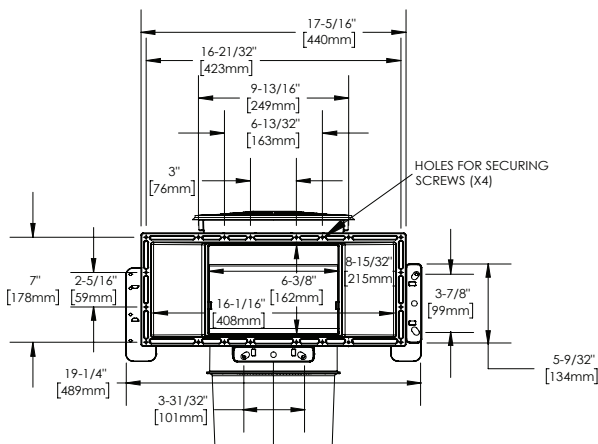

#### CUT OUT PANEL OTHER THAN WOOD

A - HEIGHT MIN 6" (152 mm) MAX 6-1/4" (159 mm)

B - WIDTH MIN 15-9/16" (395 mm) MAX 15-13/16" (402 mm)

#### CUT OUT PANEL FOR WOOD PANEL WITH VINYL LINER

A-HEIGHT MIN 7-11/16" (195 mm) MAX 7-15/16" (202 mm)

B-WIDTH MIN 17-7/16" (443 mm) MAX 17-11/16" (449 mm)

*DRILL or PUNCH 16 HOLES 1/4" DIAMETER AS SHOWN*

## FACE INSTALLATION INSTRUCTIONS

Figure 7: Skimmer Installation Cut-away

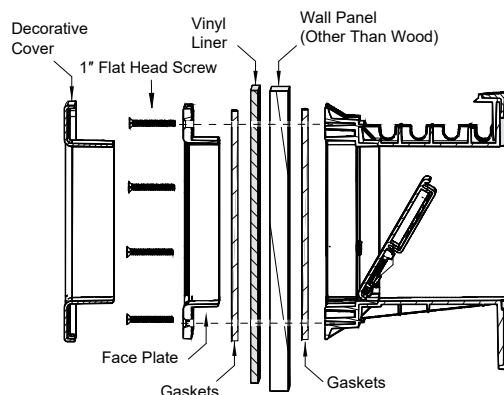

### INSTRUCTIONS FOR OTHER THAN WOOD PANEL

(See Figure 7)

1. Drill and cut wall panel section per above dimensions on previous page.
2. Place gasket on skimmer face, making sure holes in gasket align with holes in skimmer face. A very light application of silicon sealant will assist in holding gasket in place.
3. Align skimmer face and gasket with drilled panel holes and fasten to wall panel. For SKR36xxx use the top center and bottom center holes with the pan head securing screws (Figure 8). Use appropriate holes and four screws.
4. If vinyl liner pool, install liner before proceeding to step 5.
5. Align second gasket and face plate. Tightly fasten the skimmer face with provided screws. If vinyl liner pool, pierce liner through face plate holes one at a time prior to inserting screws. Screws must go through face frame, gasket, liner, wall panel, gasket, and into skimmer face.
6. Install skimmer face cover, (Not available with SKR36xxx). If vinyl liner pool, cut out liner along inside edge of the skimmer face cover.

Figure 8: SKR36xxx Securing Screws

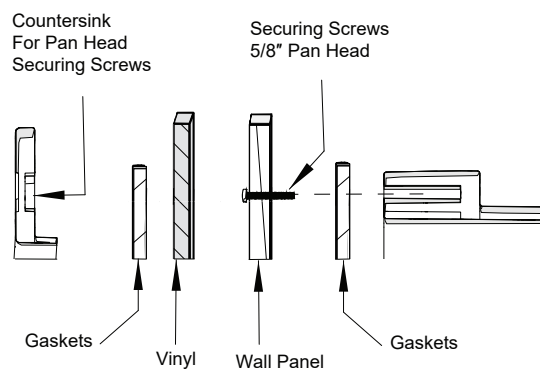

### INSTRUCTIONS FOR WOOD PANEL WITH VINYL

(See Figure 8)

1. Cut out wall panel approximately 1/8" larger than outside dimensions of skimmer face (NOT face frame or cover).
2. Insert skimmer into panel cut out from rear. Butt the mounting flange against the rear of the panel. Use "U" shims, if necessary to make the face of the skimmer flush with the inside of the pool. Fasten the skimmer to the rear of the wood panel by securing with stainless or brass wood screws through the skimmer mounting flange.
3. Place gasket on skimmer face, make sure the holes in the gasket align with holes in skimmer face. A very light application of silicon sealant will assist in holding gasket in place.
4. Install vinyl liner.
5. Align second gasket and face plate. Fasten tightly to skimmer face with provided screws. Pierce liner through face plate holes one at a time by inserting screws.
6. Install skimmer face cover, (Not available with SKR36xxx). Cut out liner along inside edge of the skimmer face cover.

## LIMITED WARRANTY

Skimmers manufactured by AquaStar are warranted to be free of defects in material and workmanship for one year from date of installation. The foregoing warranties relate to the original consumer purchaser ("Purchaser") only. AquaStar shall have the option to repair or replace the defective product, at its sole discretion. Purchasers must pay all labor and shipping charges necessary to replace the product covered by this warranty. Requests for warranty service must be made through the installing dealer. This warranty shall not apply to any product that has been subject to negligence, misapplication, improper installation or maintenance, or other circumstances which are not in AquaStar's direct control. This warranty sets forth AquaStar's sole obligation and Purchaser's exclusive remedy for defective products. AQUASTAR SHALL NOT BE LIABLE FOR ANY CONSEQUENTIAL, INCIDENTAL OR CONTINGENT DAMAGES WHATSOEVER. THE FOREGOING WARRANTIES ARE EXCLUSIVE AND IN LIEU OF ALL OTHER EXPRESS WARRANTIES. IMPLIED WARRANTIES, INCLUDING BUT NOT LIMITED TO THE IMPLIED WARRANTIES OF MERCHANTABILITY AND FITNESS FOR A PARTICULAR PURPOSE, AND SHALL NOT EXTEND BEYOND THE DURATION OF THE APPLICABLE EXPRESS WARRANTIES PROVIDED HEREIN. Some states do not allow the exclusion or limitation of incidental or consequential damages or limitations on how long an implied warranty lasts, so the above limitations or exclusion may not apply to you. This warranty gives you specific legal rights and you may also have other rights which vary from state to state. Supersedes all previous publications.