

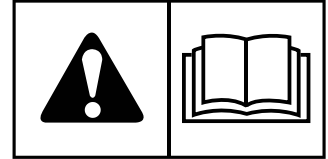

COMMERCIAL RIDE ON DEBRIS BLOWER Owner's Manual



X3001/X3002 HURRICANE RIDE ON DEBRIS BLOWER Owner's Manual

5902130, 5902184

Original Instructions

IMPORTANT- READ CAREFULLY BEFORE USE AND KEEP FOR FUTURE REFERENCE

Table of Contents:

General Information.....	3	Clean the Engine Compartment Area with Pressurized Air and Water.....	22
Using Your Operator's Manual.....	3	Engine Maintenance.....	22
Products Covered by This Manual.....	3	Containing Spilled Fluids and Proper Disposal of Waste.....	22
Product Identification.....	3	Inspect Muffler and Spark Arrester.....	23
Operator Safety.....	5	Fuse Location and Identification.....	23
Safety Alert Symbol and Signal Words.....	5	Checking Tire Pressures.....	23
California Proposition 65.....	5	Check/Fill Transmission Oil Level.....	23
Operating Training Required.....	5	Changing Hydraulic Oil and Filter.....	23
Preparation.....	5	Purging the Air from the Hydraulic System.....	25
Operating Safely.....	5	Inspect/Remove Impeller.....	25
Using a Spark Arrester.....	6	Change Drive Belt.....	25
Checking Working Area.....	6	Service Parking Brake.....	26
Parking Safely.....	6	Adjust the Position of the Motion Control Levers.....	26
Rotating Impeller is Dangerous.....	6	Neutral Adjustment.....	27
Protect Children.....	6	Deflector Control and Motor Output Test Procedure.....	27
Avoid Tipping.....	7	Clean the Battery and Cables.....	27
Slope Identification Guide.....	7	Battery Service.....	28
Keep Riders Off.....	7	Troubleshooting.....	29
Avoid High Pressure Fluids.....	7	Troubleshooting the Unit.....	29
Checking Wheel Hardware.....	8	Troubleshooting the Blower.....	30
Wear Appropriate Clothing.....	8	Specifications.....	31
Maintenance and Storage.....	8	Warranty Statement.....	32
Prevent Fires.....	8	Evaporative Emissions Warranty.....	33
Tire Safety.....	8		
Handling Fuel Safely.....	8		
Handling Waste Product and Chemicals.....	9		
Safety Decals And Icons.....	9		
Test the Safety Systems.....	10		
Features and Controls.....	12		
Control Functions and Locations.....	12		
Operation.....	15		
Before First Time Operation.....	15		
Checks Before Starting.....	15		
Starting the Engine.....	15		
Stopping the Unit.....	15		
Driving the Unit.....	15		
Using the Blower and Deflector Controls.....	17		
Pushing the Unit by Hand.....	18		
Storage.....	18		
Maintenance Schedule.....	20		
Maintenance Procedures.....	21		
Before Maintaining Your Unit.....	21		
Checking/Adding Fuel.....	21		
Replace the Fuel Filter.....	21		
Check Engine Oil Level.....	21		
Change the Engine Oil and Filter.....	21		

General Information

Using Your Operator's Manual

This manual is an important part of your unit and should remain with the unit when you sell it.

Use the safety and operating information in the unit's Operator's Manual to operate and service the unit safely and correctly.

This operator's manual explains the features and promotes the safe use of this unit. Please read it in its entirety and follow the instructions carefully so that you may have many years of safe and productive operation.

An engine manufacturer's owner's manual has been provided with your unit. This will provide maintenance and troubleshooting information for the engine installed in your unit.

Products Covered by This Manual

The following products are covered by this manual:

5902130 & 5902184

The images in this document are representative, and are meant to complement the instructional copy they accompany. Your unit may vary from the images displayed. *LEFT* and *RIGHT* are as seen from the operator's position.

Billy Goat is a registered trademark of Briggs & Stratton.

The Illustrated Parts Lists for this machine can be downloaded from billygoat.com. Please provide model and serial number when ordering replacement parts.

Product Identification

The product identification tag (A, Figure 1) can be found in the area on the unit as shown in Figure 1.

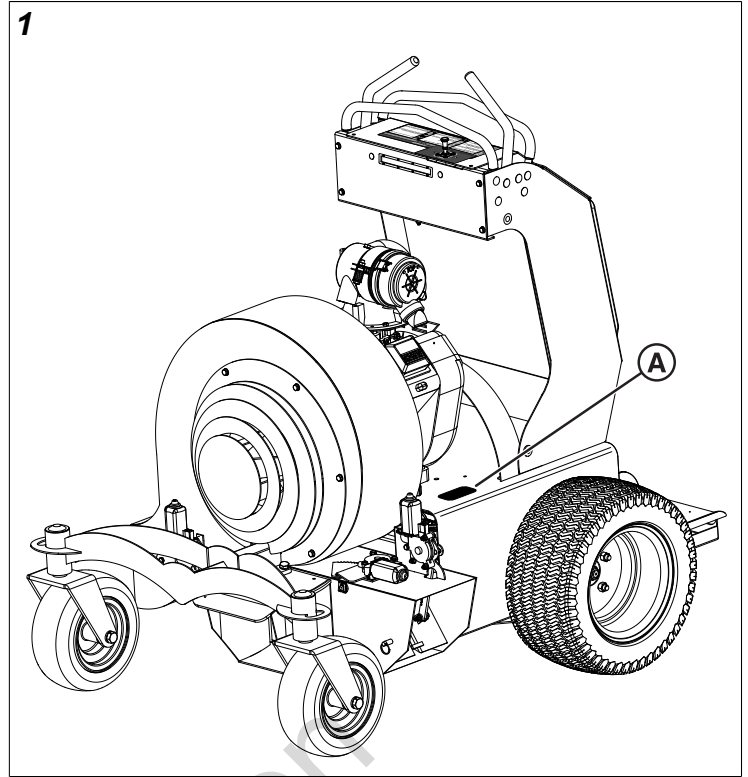

Your unit may feature a serial tag that looks like either one of the following two options:

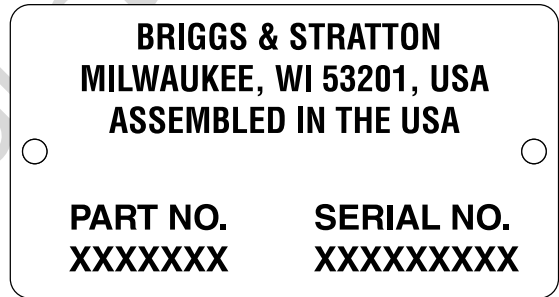

Record your model number, serial number, and engine model and serial numbers in the space provided for easy access.

PRODUCT REFERENCE DATA	
Unit Model Number:	
Unit Serial Number:	
Dealer Name:	
Date Purchased:	
ENGINE REFERENCE DATA	
Engine Make:	

ENGINE REFERENCE DATA	
Engine Model:	
Engine Type/ Specifications:	
Engine Code/Serial Number:	

When contacting your authorized service dealer for replacement parts, service, or information you **MUST** have these numbers.

Note: For the location of the engine identification numbers, refer to engine owner's manual.

Not for
Reproduction

Operator Safety

Read these safety rules and follow them closely. Failure to obey these rules could result in loss of control of the unit, severe personal injury or death to you, or bystanders, or damage to property or equipment.

The safety alert triangle () in text signifies important cautions or warnings which must be followed.

Safety Alert Symbol and Signal Words

The safety alert symbol () identifies safety information about hazards that can result in personal injury. A signal word (**DANGER**, **WARNING**, or **CAUTION**) is used with the alert symbol to indicate the likelihood and the potential severity of injury. In addition, a hazard symbol may be used to represent the type of hazard.

 **DANGER** indicates a hazard which, if not avoided, **will** result in death or serious injury.

 **WARNING** indicates a hazard which, if not avoided, **could** result in death or serious injury.

 **CAUTION** indicates a hazard which, if not avoided, **could** result in minor or moderate injury.

NOTICE indicates information considered important but not hazard-related.

California Proposition 65

WARNING

This product can expose you to chemicals including gasoline engine exhaust, which is known to the State of California to cause cancer and carbon monoxide, which is known to the State of California to cause birth defects or other reproductive harm. For more information go to www.P65Warnings.ca.gov.

Operating Training Required

- Read the operator's manual and other training material. If the operator or mechanic cannot read English, it is the owner's responsibility to explain this material to them. This publication is available in other languages.
- Become familiar with the safe operation of the equipment, operator controls, and safety signs.
- All operators and mechanics should be trained. The owner of the unit is responsible for training the users.
- Never let children or untrained people operate or service the equipment. Local regulations may restrict the age of the operator.
- The owner/user can prevent, and is responsible for, accidents or injuries occurring to themselves, other people, and/or property.

- Train operators on the unit in an open, unobstructed area under the direction of an experienced operator.

Preparation

- Evaluate the terrain to determine what accessories and attachments are needed to properly and safely perform the job. Use only accessories and attachments approved by the manufacturer.
- Wear appropriate clothing including a hard hat, safety glasses, and hearing protection. Tie back long hair, remove loose clothing or jewelry that may get tangled in moving parts.
- Inspect the area where the equipment is to be used and remove all objects such as rocks, toys, etc. which can be thrown by the unit.
- Use extra care when handling gasoline or other fuels. They are flammable and vapors are explosive.
- Allow engine to cool down before fueling.
 1. Use only an approved container.
 2. Never remove the fuel cap or add fuel when the engine is running. Do not smoke.
 3. Never add fuel or drain fuel from the unit while it is indoors.
- Check that the operator's presence controls, safety switches, and shields are attached and functioning properly. **DO NOT** operate unless they are functioning properly.

Operating Safely

- **NEVER** run an engine in an enclosed area where dangerous carbon monoxide fumes can collect.
- Only operate in good light, keeping away from holes and hidden hazards.
- Be sure all drives are in NEUTRAL and parking brake is ENGAGED before starting the engine. Only start the engine from the operator's position.
- Slow down and use extra care on hillsides. Be sure to travel in the recommended direction on slopes. For this unit, drive **across** hillsides, **not up and down**. Turf conditions can affect the machine's stability. Use caution while operating near drop-offs. **DO NOT** operate the unit within 5 feet of an embankment or drop-off.
- Slow down and use caution when making turns and when changing directions on slopes.
- **NEVER** operate with the shields, or other guards, not securely in place. Be sure all interlocks are attached, adjusted properly, and functioning properly.
- Do not change the engine governor setting or overspeed the engine. Operating the engine at excessive speed can increase the hazard of personal injury and damage to the unit.
- Stop on level ground, engage the parking brake, close the deflectors, and shut off the engine before leaving the operator's position for any reason.

- Stop the equipment and inspect the impeller if an abnormal vibration occurs. Make necessary repairs before resuming operations.
- Keep hands and feet away from the intake and discharge.
- Look behind and down before backing up to be sure of a clear path.
- Never carry passengers. Keep pets and bystanders away.
- Slow down and use caution when making turns and crossing roads and sidewalks. Close deflectors if not blowing. Watch for traffic when operating near or crossing roadways.
- Be aware of the blower discharge direction and **DO NOT** point it at anyone.
- **DO NOT** operate the unit while under the influence of alcohol and/or drugs.
- Use care when loading or unloading the unit into or off of a trailer or truck.
- Use care when approaching blind corners, shrubs, trees, or other objects that may obscure vision.
- Inspect the unit before you operate. Make sure hardware is tight. Repair or replace damaged, badly worn, or missing parts. Make sure guards and shields are in good condition and fastened in place. Make any necessary adjustments before you operate.
- Before using, **always visually inspect** to see that the impeller, its bolt, and the blower assembly are not worn or damaged. Replace worn or damaged impeller and bolt.
- Keep safety decals visible when installing accessories and attachments.
- Do not wear radio or music headphones. Safe service and operation require your full attention.
- When the unit is left unattended, stored, or parked, remove the key.

Using a Spark Arrester

The engine in this unit is equipped with a spark arrester muffler. It is a violation of California Public Resource Code Section 4442 to use or operate this engine on or near any forest-covered, brush-covered or grass-covered land unless the exhaust system is equipped with a spark arrester meeting any applicable local or state laws. Other states or federal areas may have similar laws.

An installed spark arrester must be maintained in good working order by the operator.

Checking Working Area

- Evaluate the terrain to determine what accessories and attachments are needed to properly and safely perform the job.
- **Clear work area** of objects that might be thrown. Keep people and pets out of working area.
- Study working area. Set up a safe blowing pattern. Do not blow where traction or stability is doubtful.
- Test drive through area with all deflectors closed. Slow down when you travel over rough ground.

Parking Safely

1. Stop the unit on a flat, level surface and release the motion control levers. The levers will automatically pivot outwards and engage the parking brake. Close the deflectors, turn the ignition switch to OFF, and remove the key.
2. Wait for the engine and all moving parts to stop before you leave the operator's station.
3. Close the fuel shut-off valve, if your unit is equipped.
4. Disconnect the negative battery cable or remove the spark plug wires (for gasoline engines) before servicing the unit.

Rotating Impeller is Dangerous



WARNING

Rotating impeller can cut off arms and legs, and throw objects. Failure to observe safety instructions could result in serious injury or death.

- **Keep hands, feet and clothing away** from blower housing when engine is running.
- Be alert at all times, drive forward carefully. People, especially children can move quickly into the working area before you know it.

Protect Children

- Death or serious injury can occur when young children associate having fun with lawn equipment simply because someone has given them a ride on a unit.
- Children are attracted to lawn equipment and activities. They don't understand the dangers or the fact that the operator is unaware of their presence.
- Children who have been given rides in the past may suddenly appear in the work area for another ride and be run over or backed over by the unit.
- Tragic accidents with children can occur if the operator is not alert to the presence of children, especially when a child approaches a unit from behind. **Before and while backing up, look down and behind the unit carefully, especially for children.**
- **NEVER** carry children on a unit or attachment. Do not tow children in a cart or trailer. They can fall off and be seriously injured or interfere with safe unit operation.
- Never use the unit as a recreational vehicle or to entertain children.
- Never allow children or an untrained person to operate the unit. Instruct all operators not to give children a ride on the unit or in an attachment.
- Keep children indoors, out of the work area, and in the watchful eye of a responsible adult, other than the operator, when a unit is being operated.
- Stay alert to the presence of children. Never assume that children will remain where you last saw them. Turn the unit OFF if a child enters the work area.

Avoid Tipping

- Slopes are a major factor related to loss-of-control and tip-over accidents, which can result in severe injury or death. **Operation on all slopes requires extra caution.**
- Blow across slopes, not up and down.
- Watch for holes, ruts, bumps, rocks, or other hidden objects. Uneven terrain could overturn the unit. Tall grass can hide obstacles.
- Choose a low ground speed so you will not have to stop while on a slope.
- Do not blow or operate unit on wet grass. Tires may lose traction.
- Tires may lose traction on slopes even though the brakes are functioning properly.
- Avoid starting, stopping, or turning on a slope. If the tires lose traction, turn and proceed slowly, straight down the slope.
- Keep all movement on slopes slow and gradual. Do not make sudden changes in speed or direction, which could cause the unit to roll over.
- Use extra care while operating unit with attachments, they can affect stability of the unit. **Do not use on steep slopes.**
- Do not blow near drop-offs, ditches, embankments, or bodies of water. The unit could suddenly roll over if a wheel goes over the edge or the edge caves in.
- Follow the manufacturer's recommendations for wheel weights or counterweights for added stability when operating on slopes or using front or rear mounted attachments. Remove weights when not required.
- Drive unit very slowly and avoid quick stops.

Slope Identification Guide

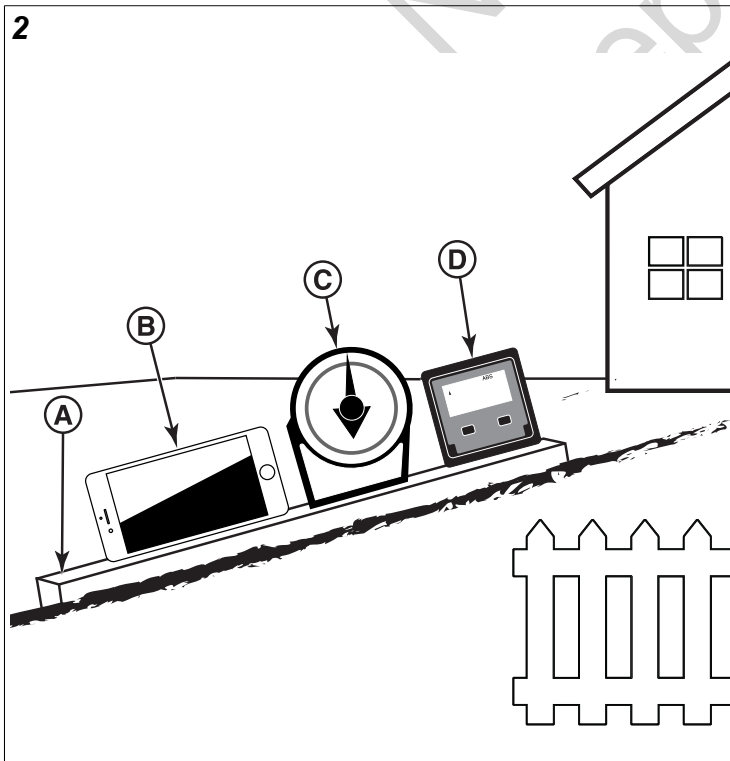

How to measure the slope of a lawn surface with a smartphone or an angle finder tool:



WARNING

Do not operate on slopes greater than 12 degrees.

1. Use a straight edge at least two (2) feet long (A, Figure 2). A 2x4 or a straight piece of metal works well.
2. Angle finder tools.
 - a. **Use your smartphone:** Many smartphones (B, Figure 2) have an inclinometer (angle finder) located under the compass application (app). Or, search an app store for an Inclinometer app.
 - b. **Use angle finder tools:** Angle finder tools (C and D, Figure 2) are available at local hardware stores or online (also called inclinometer, protractor, angle meter, or angle gauge). Dial type (C) or digital type (D) work, others may not. Read and obey the user instructions supplied with the angle finder tool.
3. Put the two (2) feet long straight edge along the steepest part of the lawn slope. Put the board up and down the slope.
4. Lay the smartphone or angle finder tool on the straight edge and read the angle in degrees. This is the slope of your lawn.

Note: A paper gauge slope identification guide is included in your product literature packet and is also available to download from the manufacturer's website.

Keep Riders Off

- Only allow the operator on the unit. Keep riders off.
- Riders on the unit or attachment may be struck by foreign objects or thrown off the unit causing serious injury.
- Riders obstruct the operator's view resulting in the unit being operated in an unsafe manner.

Avoid High Pressure Fluids

- Hydraulic hoses and lines can fail due to physical damage, kinks, age, and exposure. Check hoses and lines regularly. Replace damaged hoses and lines.
- Hydraulic fluid connections can loosen due to physical damage and vibration. **Check connections regularly.** Tighten loose connections.
- Escaping fluid under pressure can penetrate the skin causing serious injury. Avoid the hazard by relieving pressure before disconnecting hydraulic or other lines. Tighten all connections before applying pressure.
- Search for leaks with a piece of cardboard. Protect hands and body from high pressure fluids.
- If an accident occurs, **see a doctor immediately.** Any fluid injected into the skin must be surgically removed within a few hours or gangrene may result. Doctors unfamiliar with this type of injury should reference a knowledgeable medical source.

Checking Wheel Hardware

- An accident could occur causing serious injury if wheel hardware is not fastened.
- Check wheel hardware tightness often during the first 100 hours of operation. Torque to 90 ft-lbs (122 Nm).
- Wheel hardware must be tightened to specified torque using the proper procedure anytime it is loosened.

Wear Appropriate Clothing

- Always wear safety goggles, or safety glasses with side shields, and a hard hat when operating the unit.
- Wear close fitting clothing and safety equipment appropriate for the job.
- While blowing, always wear substantial footwear and long trousers. **DO NOT** operate the equipment when barefoot or wearing open sandals.
- Wear a suitable hearing protection device such as earplugs. Loud noise can cause impairment or loss of hearing.

Maintenance and Storage

- **NEVER** operate the unit in a enclosed area where dangerous carbon monoxide fumes can collect.
- Disengage drives, engage parking brake, stop engine and remove key or disconnect spark plug (for gas engines). Wait for all movement to stop before adjusting, cleaning or repairing.
- Clean all debris from unit, drives, mufflers, and engine to help prevent fires. Clean up oil or fuel spillage.
- Let engine cool before storing and do not store near flame.
- Shut off fuel while storing or transporting. Do not store fuel near flames or drain indoors.
- Park unit on level ground. Never allow untrained personnel to service unit. Understand service procedure before doing work.
- Use jack stands or lock service latches to support components when required. Securely support any unit elements that must be raised for service work.
- Before servicing unit or attachment, carefully release pressure from any components with stored energy, such as hydraulic components or springs.
- Release hydraulic pressure by moving hydraulic control levers back and forth with the engine OFF.
- Disconnect the battery or remove the spark plugs (for gas engines) before making any repairs. Disconnect the negative terminal first and the positive last. Reconnect positive first and negative last.
- Use care when checking impeller. Wear gloves and use caution when servicing the impeller. Only **REPLACE** impeller. **Never attempt to straighten or weld an impeller.**
- Keep hands, feet, clothing, jewelry, and long hair away from moving parts. If possible, do not make adjustments with the engine running.
- Charge battery in an open well ventilated area, away from spark and flames. Unplug charger before connecting or

disconnecting from battery. Wear protective clothing and use insulated tools.

- Keep all parts in good working condition and all hardware tightened. Replace all worn or damaged decals.
- Keep all nuts and bolts tightened securely, especially impeller attachment bolts, to be sure the equipment is in safe working condition.
- **Check brake operation frequently.**

Prevent Fires

- Remove debris from engine compartment and muffler area, before and after operating unit, especially after blowing in dry conditions.
- **ALWAYS** shut off fuel when transporting or storing unit, if the unit is equipped with a fuel shut off valve.
- **DO NOT** store unit near an open flame or source of ignition, such as a water heater or furnace.
- Check fuel lines, tank, cap, and fittings frequently for cracks or leaks. Replace if necessary.

Tire Safety

Explosive separation of a tire and rim parts can cause serious injury or death:

- Do not attempt to mount a tire without the proper equipment and experience to perform the job.
- Always maintain the correct tire pressure. **DO NOT** inflate the tires above the recommended pressure. Never weld or heat a wheel and tire assembly. The heat can cause an increase in air pressure resulting in a tire explosion. Welding can structurally weaken or deform the wheel.
- When inflating tires, use a clip-on chuck and extension hose long enough to allow you to stand to one side and NOT in front of or over the tire assembly.
- Check tires for low pressure, cuts, bubbles, damaged rims or missing studs and nuts.

Handling Fuel Safely

To avoid personal injury or property damage, **use extreme care when handling fuel.** Fuel is extremely flammable and fuel vapors are explosive:

- Extinguish all cigarettes, cigars, pipes, and other sources of ignition.
- Use only an approved fuel container. Use only non-metal, portable fuel containers approved by the Underwriter's Laboratory (U.L.) or the American Society for Testing & Materials (ASTM). If using a funnel, make sure it is plastic and has no screen or filter.
- Never remove the fuel tank cap or add fuel with the engine running. Allow engine to cool before refueling.
- Never add fuel to or drain fuel from the unit indoors. Move unit outdoors and provide adequate ventilation.
- Clean up spilled fuel immediately. If fuel is spilled on clothing, change clothing immediately. If fuel is spilled near unit, do not attempt to start the engine but move the unit away from the area of spillage. Avoid creating any source of ignition until fuel vapors have dissipated.

- Never store the unit or fuel container where there is an open flame, spark, or pilot light such as on a water heater or other appliance.
- Prevent fire and explosion caused by static electric discharge. Static electric discharge can ignite fuel vapors in an ungrounded fuel container.
- Never fill containers inside a vehicle or on a truck or trailer bed with a plastic liner. Always place containers on the ground away from your vehicle before adding fuel.
- Remove fuel-powered equipment from the truck or trailer and add fuel to it on the ground. If this is not possible, then add fuel to such equipment with a portable container, rather than from a fuel dispenser nozzle.
- Keep the nozzle in contact with the rim of the fuel tank or container opening at all times until you have finished adding fuel. Do not use a nozzle lock open device.
- **Never overfill fuel tank.** Replace fuel tank cap and tighten securely.
- Replace all fuel container caps securely after use.
- For gasoline engines, do not use gas with methanol. Methanol is harmful to your health and to the environment.

Handling Waste Product and Chemicals

Waste products, such as used oil, fuel, coolant, brake fluid, and batteries, can harm the environment and people:

- **DO NOT** use beverage containers for waste fluids - someone may drink from them.
- Contact your local Recycling Center or authorized dealer to learn how to recycle or dispose of waste products.
- Safety Data Sheets (SDS) provides specific details on chemical products: physical and health hazards, safety procedures, and emergency response techniques. The seller of the chemical products used with your unit is responsible for providing the SDS for that product.

Safety Decals And Icons

Read the safety decals before operating your unit. The cautions and warnings are for your safety. Understand and follow all safety decals to reduce the risk of a personal injury or property damage.



WARNING

If any safety decals become worn or damaged and cannot be read, order replacement decals from your local authorized Billy Goat servicing dealer.

3

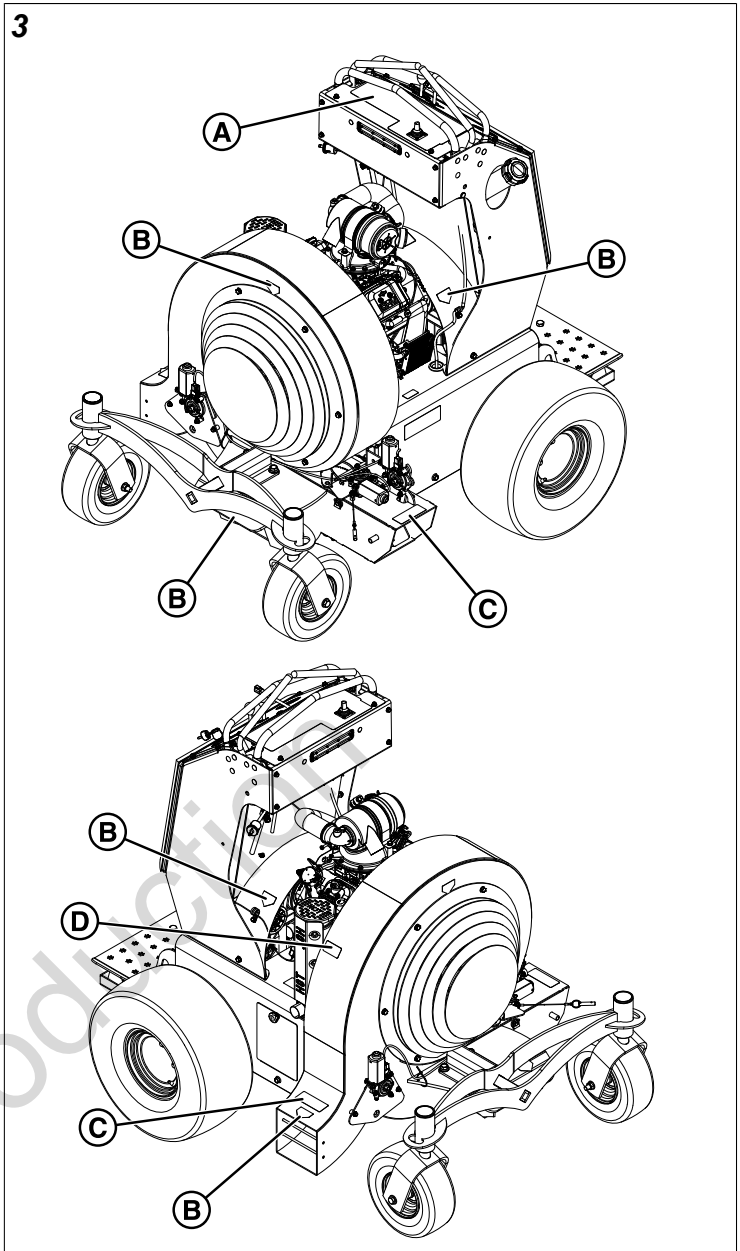







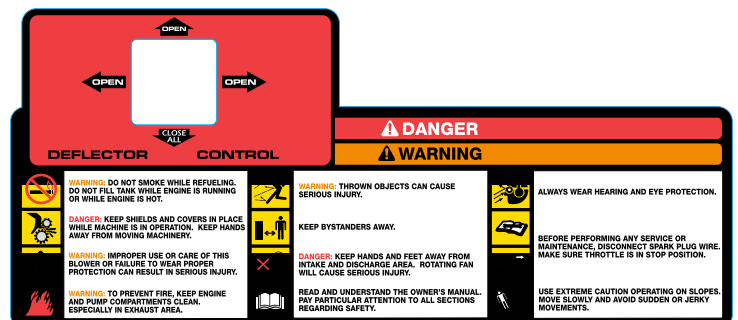





- A. 5107509FS - Main Safety Decal
- B. 5106775FS - Blower Danger Decal
- C. 5106773FS - Pinch Point Decal
- D. 5106771FS - Hot Surface Decal

Main Safety Decal

Part Number: 5107509FS



	The safety alert triangle signifies important cautions or warnings which MUST be followed.
	WARNING: Do not smoke while refueling. Do not fill tank while engine is running or while engine is hot.
	DANGER: Keep shields and covers in place while machine is in operation. Keep hands away from moving machinery.
	WARNING: Improper use or care of this blower or failure to wear proper protection can result in serious injury.
	WARNING: To prevent fire, keep engine and pump compartments clean. Especially in exhaust area.
	WARNING: Thrown objects can cause serious injury.
	Keep Bystanders away.
	DANGER: Keep hands and feet away from intake and discharge area. Rotating fan will cause serious injury.
	Read and understand the owner's manual. Pay particular attention to all sections regarding safety.
	Always wear hearing and eye protection.
	Before performing any service or maintenance, disconnect spark plug wire. Make sure throttle is in STOP position.
	
	Use extreme caution operating on slopes. Move slowly and avoid sudden or jerky moments.



Blower Danger Decal
Part Number: 5106775FS



	Danger: Keep hands and feet away.
---	--



Pinch Point Decal
Part Number: 5106773FS



	The safety alert triangle signifies important cautions or warnings which MUST be followed.
	CAUTION: Pinch Point.

Hot Surface Decal
Part Number: 5106771FS



		Hot Surface
---	--	-------------

Test the Safety Systems

The safety systems installed on your unit should be tested before each use. Be sure you have read this manual and are completely familiar with the operation of the unit before performing these safety system checks.

If there is a malfunction during one of these procedures, do not operate the unit. Contact your authorized dealer for service.

Perform these tests in a clear, open area outdoors. Keep bystanders away.

Use the following procedures to check for normal operation of the unit's safety systems.

Test Park Brake Switch (Start)

1. Turn the ignition switch key to the ON position.
2. Push both motion control handles down to disengage the parking brake.
3. Turn the ignition switch key to the START position.

Result: The engine must not crank.

Test Neutral Switch (Start)

1. Push one motion control lever forward.
2. Turn ignition switch key to the START position. Repeat steps 1 and 2 for other motion control lever.

Result: The engine must not crank.

Test Emergency Parking Brake Release

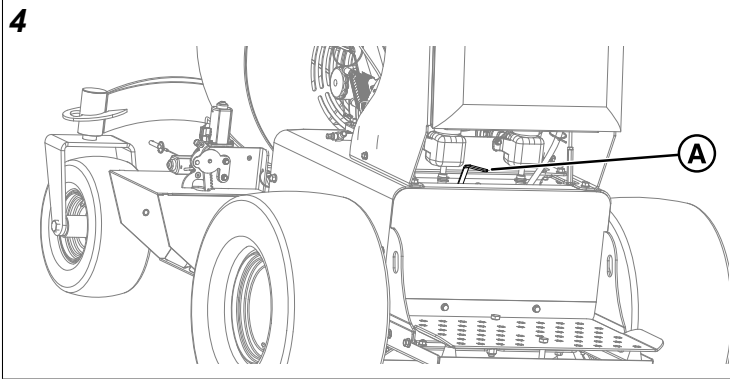

1. Turn ignition switch key to the ON position.
2. Lift the emergency brake release lever (A, Figure 4). You will hear the brake disengage and reset.
3. Turn ignition switch key to the START position.

Result: The engine will turn over. This means all brake safety switches are working properly.

Test the Parking Brake

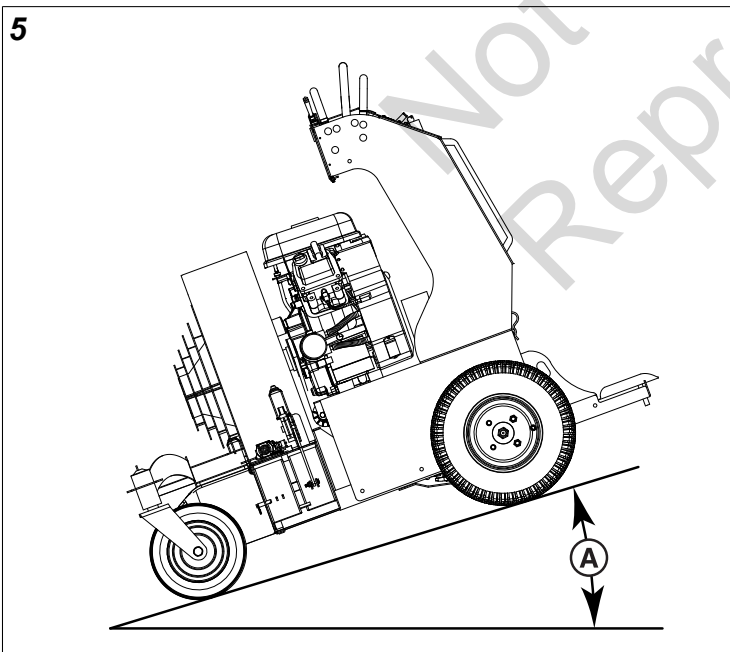

1. Stop the unit on a 17° slope (30% grade) (A, Figure 5) facing downhill. Stop the engine and engage the parking brake.
2. Repeat procedure with machine facing uphill.

Result: The parking brake must hold the unit stationary. (Unit should move no more than 24 in. (61 cm) in one hour.) If unit moves more than that, contact your authorized dealer.

Test Automatic Parking Brake Set

1. Stand on the operator's platform with both the motion control levers in the NEUTRAL parking brake position.
2. Start the engine. Idle the engine.
3. Disengage the parking brake.
4. Move the motion control levers slightly forward, slower than walking speed.
5. Release the motion control levers, allowing them to return to the NEUTRAL position and tilt up.

Result: The engine is running and the parking brake is now set. The unit will not roll.

Features and Controls

Control Functions and Locations

The information below briefly describes the function of individual controls. Starting, stopping, driving, and blowing require the combined use of several controls applied in specific sequences. To learn what combination and sequence of controls to use for various tasks, see the *Operation* section.

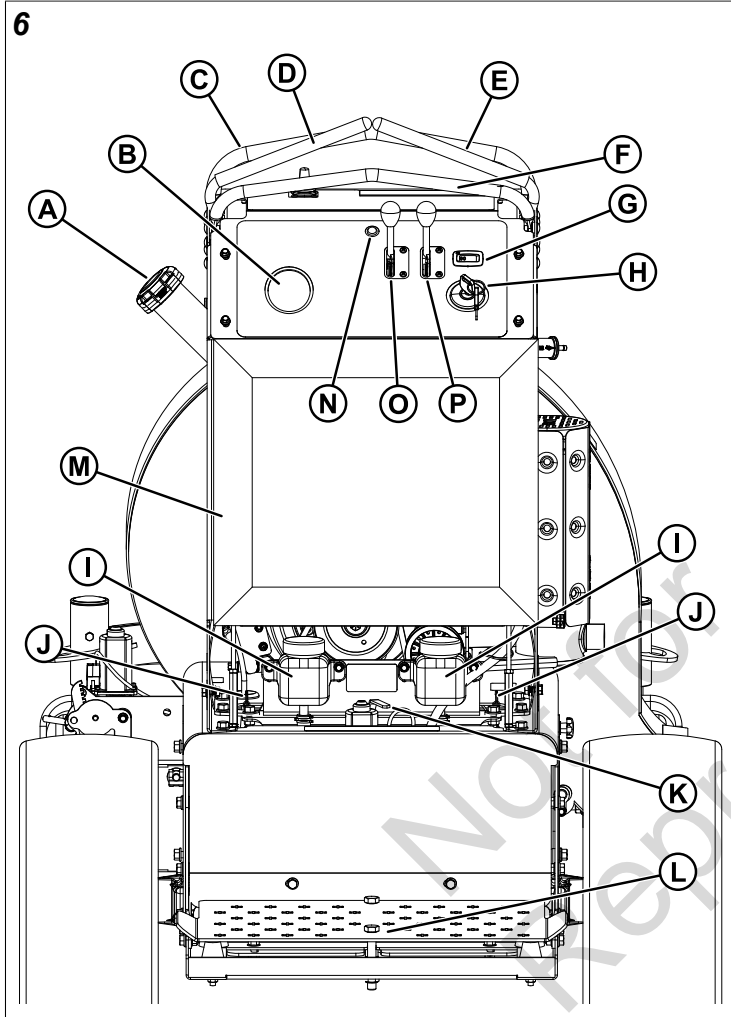

- A. Fuel Tank Cap
- B. Fuel Level Gauge
- C. Front Stationary Handle Bar
- D. Left Motion Control/Parking Brake Lever
- E. Right Motion Control/Parking Brake Lever
- F. Rear Stationary Handle Bar
- G. Tach/Hour Meter
- H. Ignition Key Switch
- I. Hydraulic Oil Tanks
- J. Hydraulic Pump Bypass Valve (one on each pump)
- K. Emergency Brake Release Lever
- L. Operator Platform
- M. Operator Cushion

- N. Oil Alert Light
- O. Choke Control
- P. Throttle Control

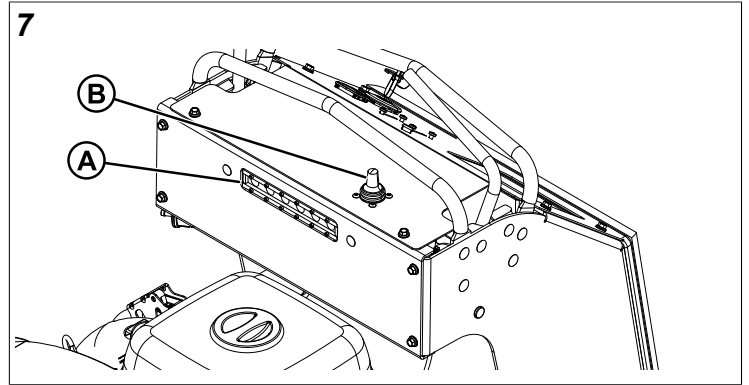

- A. Headlight
- B. Deflector Control

Fuel Tank Cap

To remove the fuel tank cap, turn **counter-clockwise**.

Fuel Level Gauge

Displays the fuel level in the tank. The fuel level gauge is installed in the top of the fuel tank and is viewed by looking through the port hole in the instrument control panel.

Motion Control/Parking Brake Levers

These levers control the ground speed, steering, and parking brake functions of the unit.

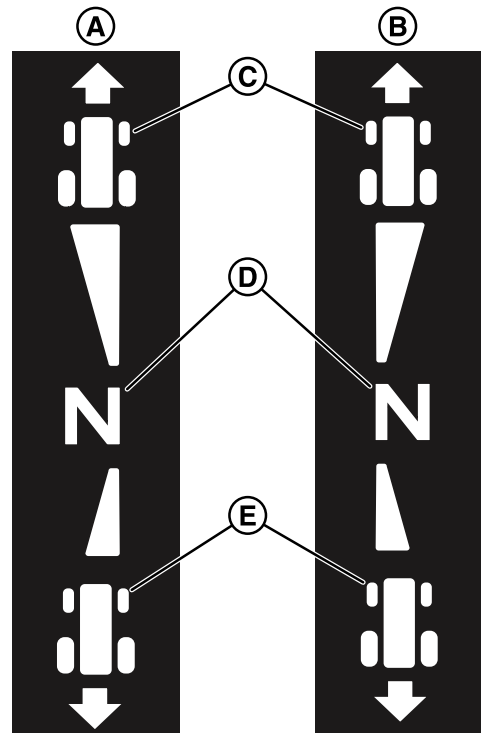

- A. Left Motion Control/Parking Brake Lever
- B. Right Motion Control/Parking Brake Lever
- C. **FORWARD** - move a lever forward towards the front stationary handlebar to increase the FORWARD speed.

- D. **NEUTRAL** - when the levers are released they automatically return to the NEUTRAL position and the movement of the unit stops.
- E. **REVERSE** - pull back on a lever towards the rear stationary handlebar to increase the REVERSE speed.

The left lever controls the left side drive wheel and the right lever controls the right side drive wheel.

The further a lever is moved away from the NEUTRAL position the faster the drive wheel will turn.

See *Driving the Unit* section for steering instructions.

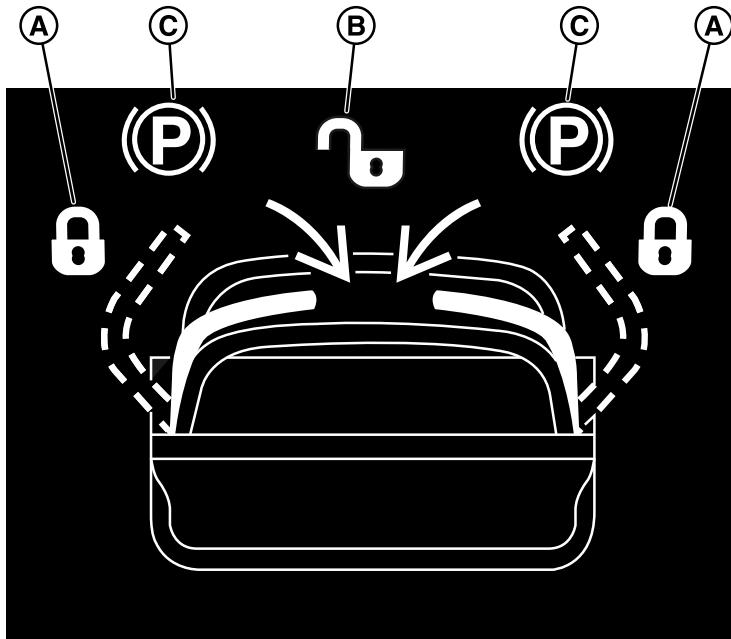

- A. **ENGAGED** - when released, the levers will automatically move up and out to engage the parking brake.
- B. **DISENGAGED** - pressing the levers down and in will release the parking brake.
- C. Parking Brake Symbol

The motion control/parking brake levers must be in the ENGAGED position for starting, parking, or when moving the unit when the ignition switch is in the OFF position.



The motion control/parking brake levers must be pressed down into the DISENGAGED position before they can be moved from the NEUTRAL position.

Tach/Hour Meter

The Tach/hour meter shows the engine revolutions per minute when the engine is running and the engine hours when engine is off. The meter will also show reminders when to change the engine oil. The meter only runs when the engine is running and is independent of the key switch.

Ignition Key Switch

The ignition switch starts and stops the engine and turns the headlight on.

	HEADLIGHT: Allows the engine to run, powers the electrical system, and turns the headlight on.
	RUN: Allows the engine to run and powers the electrical system.
	START: Cranks the engine for starting.

Hydraulic Oil Tanks

Transmission oil is added through the hydraulic oil tanks. It also serves as extra holding capacity for oil as the transmissions heat up and the hydraulic oil expands. See *Check/Fill Transmission Oil* for oil level check and fill procedures.

Hydraulic Pump Bypass Valve

This unit is equipped with two (2) hydraulic pump bypass valves. The hydraulic pump bypass valves deactivate the transaxle so that the unit can be pushed by hand. Both hydraulic pump bypass valves must be in the same position whether you are driving the unit or pushing it by hand. See *Pushing the Unit by Hand* for operational information.

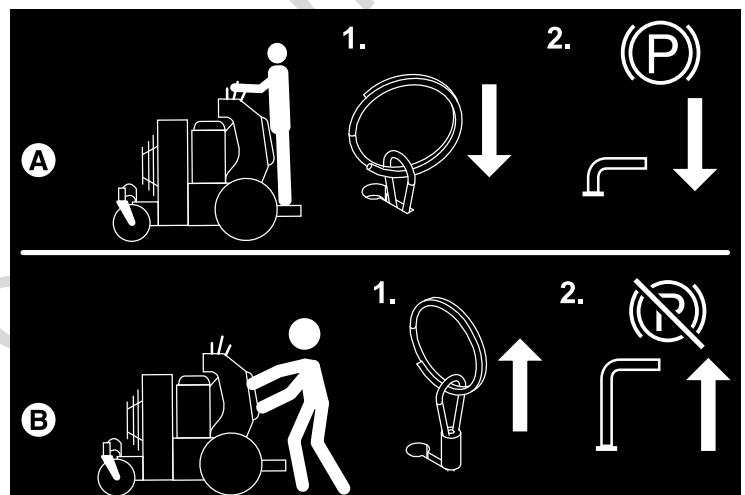

- A. **ENGAGED** (run) position.
- B. **DISENGAGED** (bypass) position.

Emergency Brake Release Lever

The emergency brake release lever is for moving the unit when the engine is not running.

Turn the ignition switch to the OFF position, move the hydraulic pump bypass valves to the disengaged position, and then pull the emergency brake release lever up to release the parking brake. After moving the unit, turn the ignition key to the RUN position to engage the parking brake. See *Pushing the Unit by Hand* for operational instructions.

Oil Alert Light



OFF: Stops the engine and shuts off the electrical system.

If the oil alert light illuminates during operation, stop the unit immediately, turn off the engine, and consult the engine operator's manual.

Choke Control Lever

Close the choke for cold starting. Open the choke once the engine starts. A warm engine may not require choking. Move the lever forward to close the choke and rearward to open the choke.



CLOSED choke position



OPEN choke position

Engine Throttle Control Lever

The throttle controls engine speed. Move the throttle forward to increase engine speed and back to decrease engine speed.



FAST engine throttle speed



SLOW engine throttle speed

Deflector Control

The deflector control adjusts the air pattern by starting and stopping an air stream. See *Using the Blower and Deflector Controls* for operational instructions.

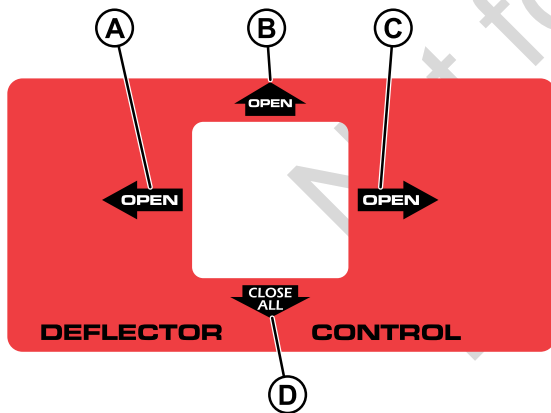

- A. **OPEN** the LEFT deflector.
- B. **OPEN** the CENTER deflector.
- C. **OPEN** the RIGHT deflector.
- D. **CLOSE ALL** deflectors.

Operation

Before First Time Operation

- Be sure to read all information in the *Operator Safety* and *Operation* sections before attempting to operate this unit.
- Become familiar with all of the controls and how to stop the unit.
- Drive in an open area to become accustomed to the unit.

WARNING

- Never operate on slopes greater than 12°.
- Select slow ground speed before driving onto a slope.
- Blow across the face of slopes, not up and down, use caution when changing direction on slopes and do NOT start or stop on a slope.

WARNING

- Never allow passengers to ride on the unit.
- Before leaving the operator's platform for any reason, engage the parking brake, turn the ignition switch to OFF, and remove the ignition key.
- To reduce fire hazard, keep the engine and unit free of grass, leaves, and excess grease. Do NOT stop or park unit over dry leaves, grass, or combustible materials.
- Fuel is highly flammable and must be handled with care. Never fill the tank when the engine is still hot from recent operation. Do NOT allow open flame, smoking, or matches in the area. Avoid over-filling and wipe up any spills.

WARNING

Do NOT load this unit on a trailer or truck using two separate ramps. Only use a single ramp that is at least one foot wider than the width of the rear wheels of this unit. This unit has a zero turning radius and the rear wheels could fall off the ramps, or the rider could tip over injuring the operator or bystanders.

Checks Before Starting

1. Check the engine oil level using the engine oil dipstick. If necessary, add oil through the engine oil fill. See the engine owner's manual for instructions, the location of the engine oil fill, engine oil dipstick, and oil recommendations.
2. Make sure that all nuts, bolts, screws and pins are in place and tight.
3. Fill the fuel tank with fresh fuel. Refer to the engine owner's manual for fuel recommendations.
4. Check the hydraulic oil level. If necessary, add oil through the hydraulic oil tanks.

Starting the Engine

WARNING

Read the operator's manual before attempting to operate this unit.

- If you do not understand how a specific control functions, or have not yet thoroughly read the *Features and Controls* section, do so now.
 - Do NOT attempt to operate the unit without first becoming familiar with the location and function of all controls.
1. While standing on the operator's platform, release the motion control levers. They will pivot out to engage the parking brake.
 2. **A warm engine may not require choking.** Position the throttle control lever to the FAST throttle position. Position the choke control lever to the CLOSED choke position. Set the engine throttle control to FAST throttle position.
 3. Insert the key into the ignition switch and turn it to START position.
 4. After the engine starts, gradually move the choke control lever to the OPEN choke position. Reduce to half throttle speed and allow engine to warm.
Warm up the engine by running it for at least a minute before driving the unit.

In the event of an emergency the engine can be stopped by simply turning the ignition switch to STOP. Use this method only in emergency situations. For normal engine shut down follow the procedure given in *Stopping the Unit*.

Stopping the Unit

1. Return the motion control levers to the NEUTRAL position. Release the levers and they will pivot out to engage the parking brake.
2. Move the throttle control lever to the mid-throttle position and turn the ignition key to OFF. Remove the ignition key.

Driving the Unit

CAUTION

Avoid injury! Learn the proper use of the motion control levers and practice at low throttle until becoming proficient and comfortable with the operation of the unit.

DO NOT rapidly move the motion control levers from FORWARD to REVERSE or REVERSE to FORWARD position. Sudden direction changes could cause loss of control or damage the unit.

The functions of the motion control levers are:

- Forward and reverse movement
- Steering
- Acceleration and Deceleration
- Stopping

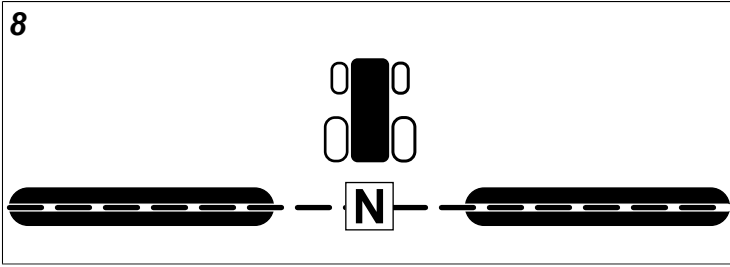

Figure 8 depicts the NEUTRAL position.

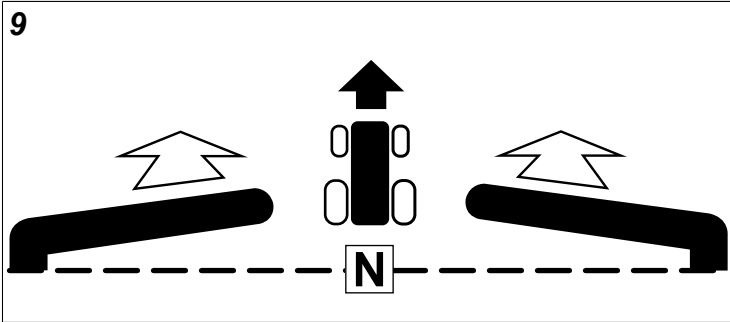

Figure 9 depicts the FORWARD travel position. The travel speed depends on how far forward the motion control levers are pushed.

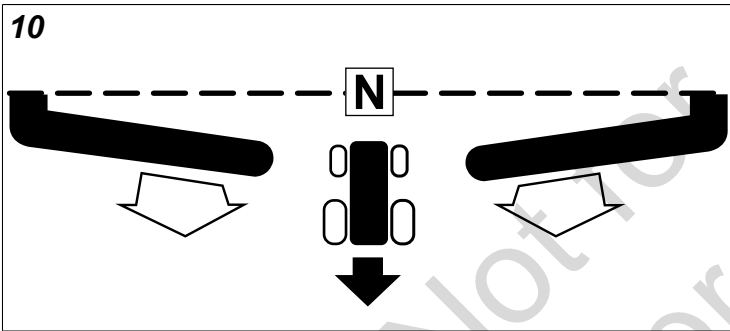
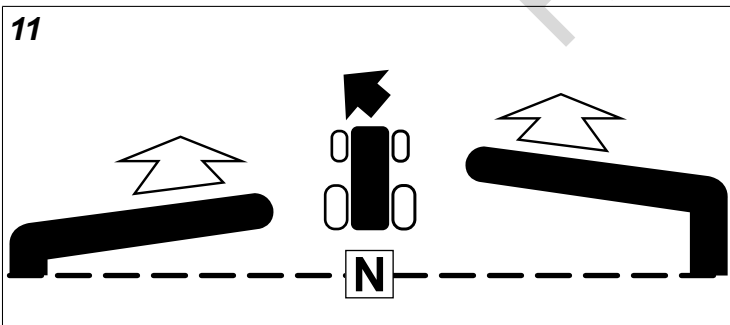
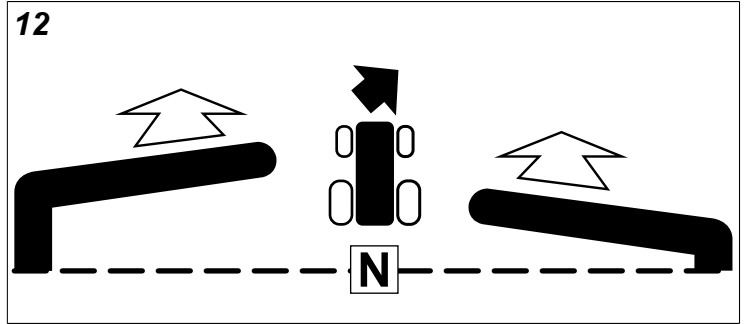

Figure 10 depicts the REVERSE travel position. The travel speed depends on how far rearward the motion control levers are pulled.



For a gentle left turn, push the right motion control lever further forward than the left motion control lever.



For a gentle right turn, push the left motion control lever further forward than the right motion control lever.

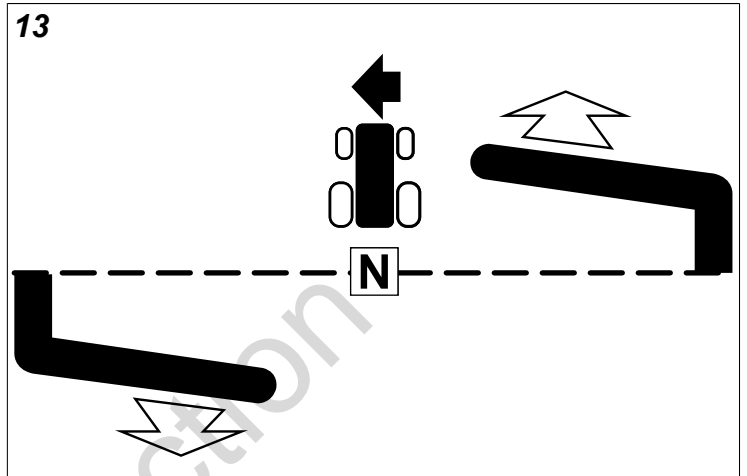

For a sharp left turn, pull the left motion control lever rearward and push the right motion control lever forward.

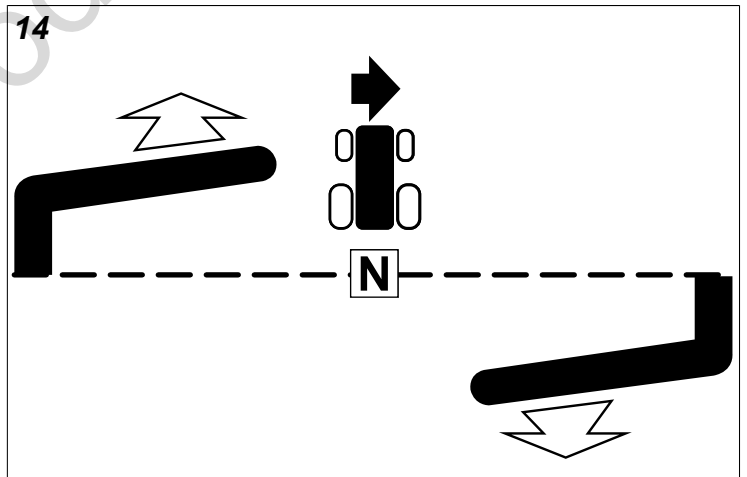

For a sharp right turn, push the left motion control lever forward and pull the right motion control lever rearward.

Using the Blower and Deflector Controls

CAUTION

Avoid injury and property damage! DO NOT position discharge where it will blow debris towards people, vehicles, buildings, or other objects in vicinity. Flying debris may damage, harm, or cause injury to people or objects in air flow range. Keep a safe distance between two or more operators and units when working together in the same areas.

CAUTION

Keep hands and feet away from air intake and air discharge. Pinch points and crushing forces will cause severe injury.

DANGER

ROTATING FAN - DO NOT attempt to remove materials from intake or discharge when blower is running. Engage parking brake, stop engine, remove key and wait until all machinery has come to a complete stop.

This unit features three discharge chutes (A, B, & C, Figure 15).

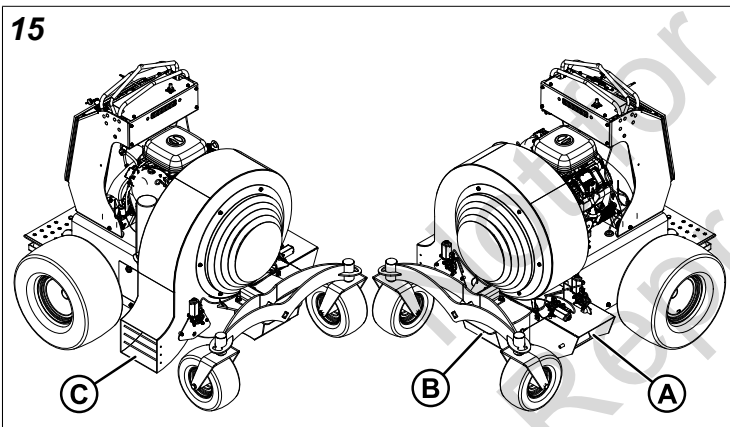

The left side deflector (A) is a dual deflector system, where the rear deflector is controlled by the deflector control and the front deflector is controlled manually with the halfway pin. The halfway pin must be removed before fully closing the left deflectors.

The front deflector (B) and the right side deflector (C) are both controlled by the deflector control.

The deflector control (A, Figure 16) can start and stop an air stream and adjust the air pattern.

16

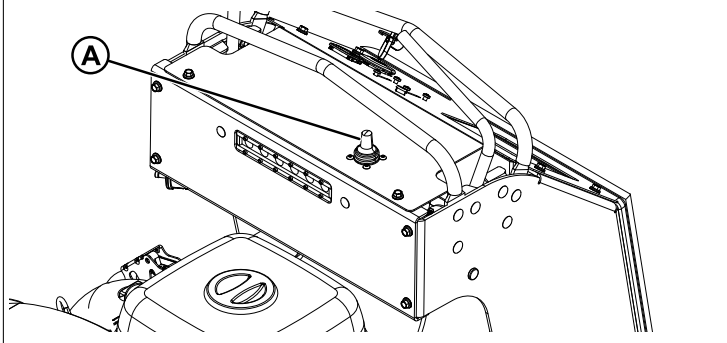

Deflector Control Operation (Models: 5902130 & 5902184)

- When the deflector control is moved to the **LEFT**, the left deflector **OPENS**, the front deflector **CLOSES**, and the right deflector **CLOSES**.
- When the deflector control is moved **FORWARD**, the front deflector **OPENS**, and the right deflector **CLOSES**.
- When the deflector control is moved to the **RIGHT**, the right deflector **OPENS**.
- When the deflector control is moved **BACKWARDS**, all deflectors **CLOSE**.

Additional Deflector Control Operation Features (Model 5902184 Only)

- When the unit is started all open deflectors will move to the **CLOSED** position.
- A quick tap of the deflector control will adjust the deflector in small increments.
- An extended tap of the deflector control (1/4 of a second or longer) will adjust the deflector until the available range of travel has been completed.
- A quick tap of the deflector control while a deflector is already in motion will stop all motion of the deflectors.
- When a deflector has completed its available range of motion in any direction and the operator is still pressing the deflector control, the control module will stop sending an electrical signal to the deflector motor.
- If a deflector has completed its available range of motion in any direction and operator presses the deflector control to make the deflector move in that same direction again, the control module will not send a signal to the electrical motor.

Note: If a blockage of a deflector occurs, or if anything disrupts the deflector's motion while it is traveling, the controller will consider this position as the end of available travel. The deflector must first be operated in the opposite direction, the blockage removed, and then the deflector can be positioned as normal.

- This unit is equipped with a test mode. See *Deflector Control and Motor Output Test*.

Dual Deflector System (Left Deflector)

The rear deflector (A, Figure 17) is controlled by the deflector motor (B). The front deflector (C) is closed by the rear deflector. For normal blowing, position the front deflector with your hand so that it rests on the halfway pin (D) and adjust the rear deflector to the desired location.

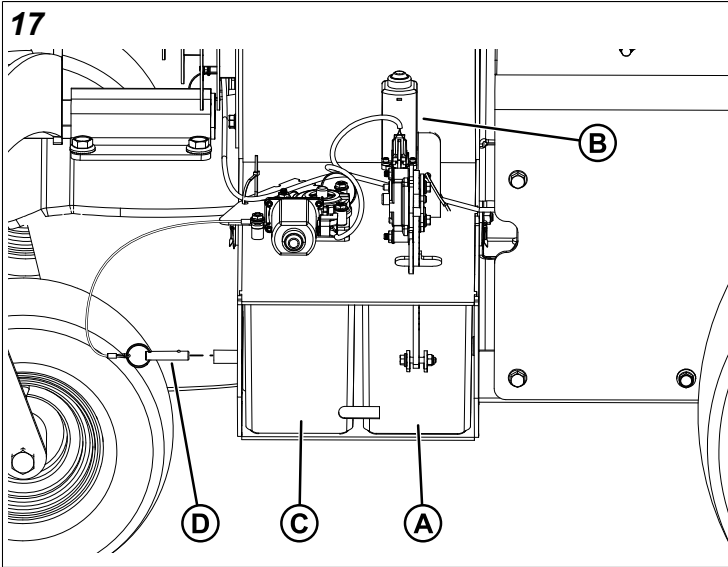

Figure 17 depicts the deflectors in the **CLOSED** position.

Note: The deflectors can be set in any position between **OPEN** and **CLOSED**.

With a little time and experience, an operator can become proficient in setting the deflectors at the optimum positions for the task.

HINT: From the operator's position, the operator can see the left deflector gear rack and judge the position of the deflectors.

With the deflectors at about half-open, the air stream is directed downward under the debris and is useful for blowing wet leaves, grass, and dirt.

For moving large piles of debris, remove the halfway pin allowing deflectors to open fully for maximum air flow.

REMEMBER: Air velocity can be controlled by the throttle control as well as by the deflectors.

REMEMBER: Air stream (deflectors) should be closed off when necessary (for example, when traveling from one area to another, past flower and bark beds, etc.).

Pushing the Unit by Hand

NOTICE

Do not tow unit.

Towing the unit can cause transaxle damage. Do not use another vehicle to push or pull this unit.

1. Stop the unit on a flat, level surface and release the motion control levers. The levers will automatically pivot outwards and engage the parking brake. Close the deflectors, turn the ignition switch to OFF, and remove the key.
2. Locate the control cable (A, Figure 18) on the rear of the unit by the hydraulic oil tanks (B). There is one control cable for each transmission. The control cables open and close the transmission bypass valves.

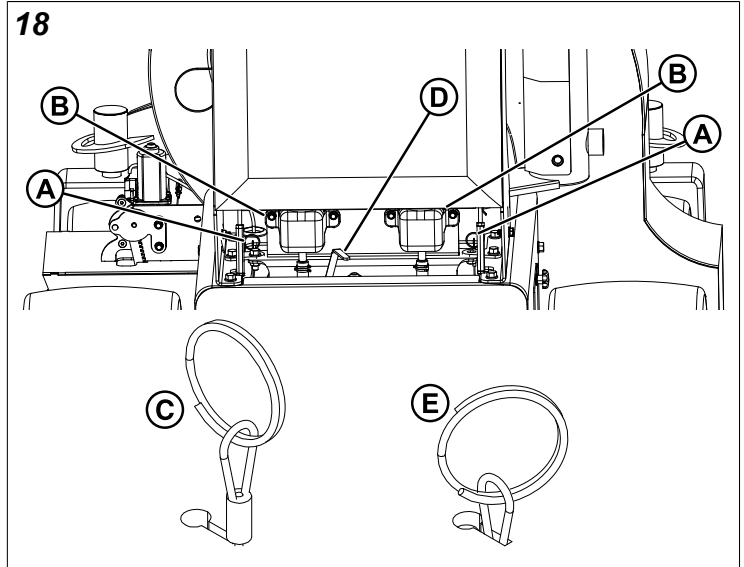

3. To open the hydraulic pump bypass valve (bypass position, C) move the control cable towards the wheel, pull up until the stop is visible, and then pull towards the center of the unit to engage the hydraulic pump bypass valve. Repeat the process for the other side of the unit.
4. Pull the emergency brake release lever (D) up to disengage the parking brake.
The unit can now be pushed by hand.
5. After moving the unit, close the bypass valve (run position, E) by pulling up on the control cable, move it towards the wheel, allow the control cable to retract the stop below the plate, and then pull the cable towards the center of the plate to lock in place. Repeat the process for the other side of the unit.

Note: Both hydraulic bypass valves must be in the same position.

Storage

Temporary Storage (30 Days or Less)

Remember, the fuel tank will still contain some gasoline, so never store the unit indoors or in any other area where fuel vapor could travel to any ignition source. Fuel vapor is also toxic if inhaled, so never store the unit in any structure used for human or animal habitation.



WARNING

Never store the unit, with gasoline in engine or fuel tank, in a heated shelter or in an enclosed, poorly ventilated enclosures. Gasoline fumes may reach an open flame, spark, or pilot light (such as a furnace, water heater, clothes dryer, etc.) and cause an explosion.

Handle gasoline carefully. It is highly flammable and careless use could result in serious fire damage to your person or property.

Drain fuel into an approved container outdoors away from open flame and sparks.

Here is a checklist of things to do when storing your unit temporarily or in between uses:

- Keep the unit in an area away from where children may come into contact with it. If there's any chance of unauthorized use, remove the spark plug(s) and put in a safe place. Be sure the spark plug opening is protected from foreign objects with suitable cover.
- If the unit cannot be stored on a reasonably level surface, chock the wheels.
- Clean all dirt and debris from the unit.

Long Term Storage (Longer Than 30 Days)

Before you store your unit for the off-season, read Maintenance and Storage instructions in the *Operator Safety* section, then perform the following steps:

1. Drain crankcase oil while engine is hot and fill with a grade of oil that will be required when unit is used again.
2. Clean external surfaces and engine.
3. Prepare engine for storage. See engine owner's manual.
4. Clean any dirt or grass from cylinder head cooling fins, engine housing and air cleaner element.
5. Cover air cleaner and exhaust outlet tightly with plastic or other waterproof material to keep out moisture, dirt, and insects.
6. Completely grease and oil unit as outlined in the *Lubrication* section.
7. Clean up unit and apply paint or rust preventative to any areas where paint is chipped or damaged.
8. Be sure the battery is fully charged. Battery life will be increased if it is removed, put in a cool, dry place and fully charged about once a month. If battery is left in unit, disconnect the negative cable.
9. Drain fuel system completely or add a gasoline stabilizer to the fuel system. If you have chosen to use a fuel stabilizer and have not drained the fuel system, follow all safety instructions and storage precautions in this manual to prevent the possibility of fire from the ignition of gasoline fumes. Remember, gasoline fumes can travel to distant sources of ignition and ignite, causing risk of explosion and fire.

Note: Gasoline, if permitted to stand unused for extended periods (30 days or more), may develop gummy deposits which can adversely affect the engine carburetor and cause engine malfunction. To avoid this condition, add a gasoline stabilizer to the fuel tank and run the engine a few minutes, or drain all fuel from the unit before placing it in storage.

Starting After Long Term Storage

Before starting the unit after it has been stored for a long period of time, perform the following steps.

1. Remove any blocks from under the unit.
2. Install the battery if it was removed.
3. Remove the covers installed into the exhaust outlet and air cleaner.
4. Fill the fuel tank with fresh gasoline. See engine manual for recommendations.

5. See engine owner's manual and follow all instructions for preparing engine after storage.
6. Check crankcase oil level and add proper oil if necessary. If any condensation has developed during storage, drain crankcase oil and refill.
7. Inflate tires to proper pressure. Check fluid levels.
8. Start the engine and let it run slowly. DO NOT run at high speed immediately after starting. Be sure to run engine only outdoors or in well ventilated area.

Maintenance Schedule

The following schedule should be followed for normal care of your unit. You will need to keep a record of your operating time. Determining operating time is easily accomplished by observing the hour meter.

UNIT MAINTENANCE
Break-In (After First 10 Hours)
Check hydraulic fluid level.
Check parking brake operation.
Check wheel lug nut torque.
Check air pressure in tires.
Check hydraulic pump drive belt.
Every 40 Hours
Check hydraulic fluid level.
Check parking brake operation.
Check wheel lug nut torque.
Check air pressure in tires.
Check hydraulic pump drive belt.
First 75 Hours
Change hydraulic oil and filters.
Monthly
Grease front caster wheels.*
Every 100 Hours
Check hydraulic pump drive belt.
Every 400 Hours or Yearly**
Change hydraulic oil and filters.
ENGINE MAINTENANCE
Before Each Use
Check engine oil level.
Clean visible debris from engine compartment and cooling fins.
Every 50 Hours
Inspect/Clean spark arrester.***
Every 100 Hours
Check fuel filter.
Refer to engine owner's manual
Service air filter.
Change engine oil and filter.
Check/Replace spark plugs.

* More often in hot (over 85° F; 30° C) weather or dusty operating conditions.

** Whichever comes first.

*** If equipped. Replace if damaged

Maintenance Procedures

Before Maintaining Your Unit

Units Equipped with Electronic Fuel Injected Engines:

If electric welding on vehicle, remove battery negative cable (black) from battery negative (-) terminal, and disconnect the ECM electrical connector(s). If welding on the muffler, also disconnect the O2 sensor electrical connector and remove the O2 sensor from the muffler.

Checking/Adding Fuel



WARNING

Gasoline is highly flammable and must be handled with care.

- Allow engine to cool for at least 3 minutes before adding fuel.
- Do NOT allow open flame, smoking, or matches in the area.
- Avoid over-filling and wipe up any spills.
- Use clean approved non-metallic container to prevent static electric discharge.
- Use clean approved non-metallic funnel with a plastic mesh strainer when filling the fuel tank.

RECOMMENDATION: Fill the fuel tank at the end of each day's operation to keep condensation out of the fuel tank.

To add fuel:

1. Stop the unit on a flat, level surface and release the motion control levers. The levers will automatically pivot outwards and engage the parking brake. Close the deflectors, turn the ignition switch to OFF, and remove the key.
2. Allow the engine to cool for at least three (3) minutes.
3. Remove any dirt and/or debris from around the fuel cap.
4. Remove the fuel cap slowly to allow any pressure built up in the tank to escape.
5. Add fuel to the fuel tank using a non-metallic funnel with a plastic mesh strainer. Only fill fuel tank to the bottom of the filler neck. Do NOT overfill. Clean up spilled fuel immediately.
6. Install the fuel cap.

Replace the Fuel Filter



WARNING

Fuel and its vapors are extremely flammable and explosive.

Fire or explosion can cause severe burns or death.

Do NOT remove the fuel filter when the engine is hot, as spilled gasoline may ignite. Do NOT spread hose clamps further than necessary. Ensure clamps grip hoses firmly over filter after installation.

If filter is dirty or clogged, replace as follows:

1. Turn the fuel shut off valve (A, Figure 19) to OFF.

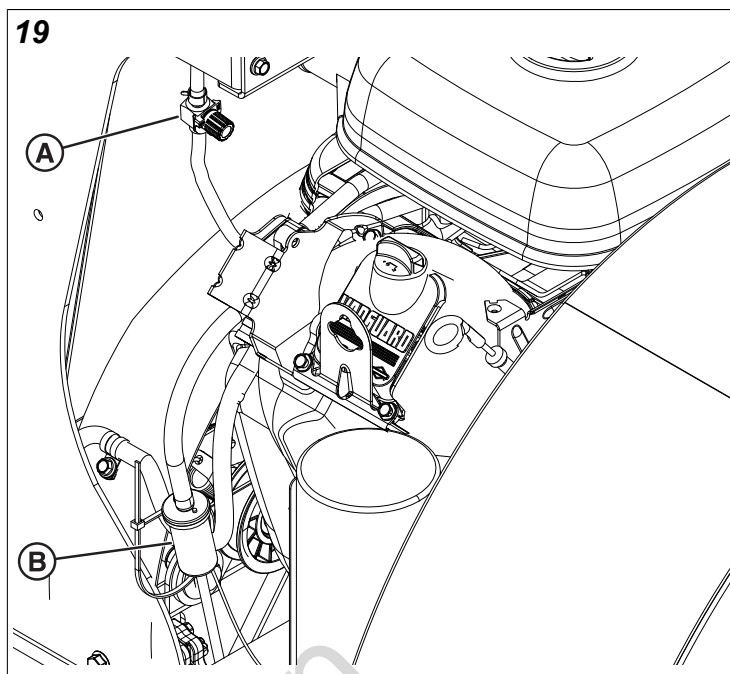

2. Disconnect the negative battery cable.
3. Place a container below the filter to catch spilled fuel.
4. Use pliers to open and slide hose clamps from the fuel filter (B).
5. Remove hoses from filter.
6. Install new filter in proper flow direction in fuel line.
7. Secure with hose clamps.
8. Reconnect the negative battery cable when finished.
9. Turn the fuel shut off valve to ON.

Check Engine Oil Level

Interval: Before Each Use

Refer to the engine operator's manual for dipstick and oil fill locations and specific engine oil check and fill procedures.

Change the Engine Oil and Filter

NOTICE

Avoid damage! Change the engine oil and filter more often if the unit is used in the following conditions:

- Extremely dusty conditions.
- Frequent slow or low-speed operation.
- Frequent short trips.

1. Warm the engine by running for a few minutes. (Refer to the engine operator's manual for oil & filter replacement instructions.)
2. Place an oil drain pan beside the engine on the oil drain valve side.
3. Place 18" of 1/2" ID hose (A, Figure 20) onto the drain valve (B).

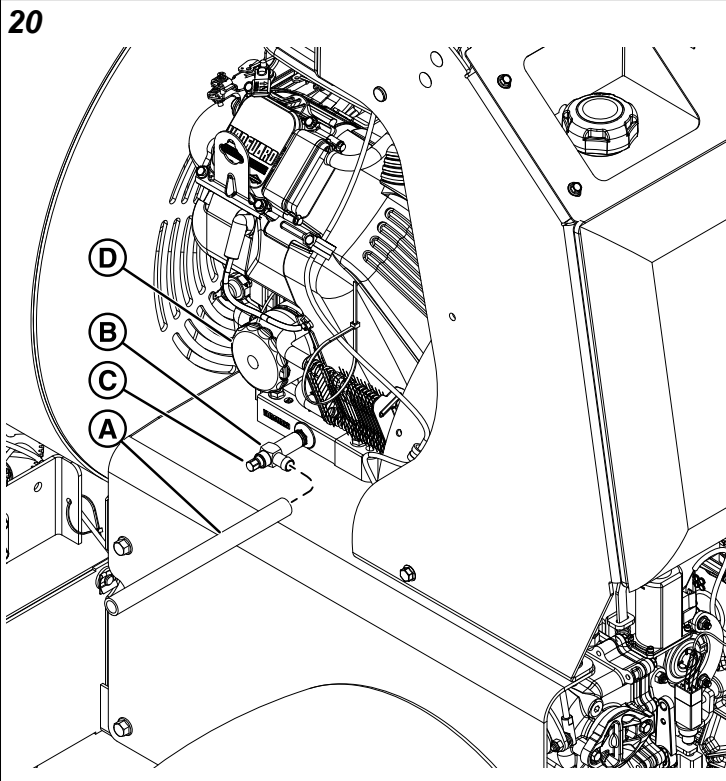

4. Open the oil drain valve (C) fully.
5. Allow oil to drain into an oil drain pan.
6. After oil drains, securely tighten oil drain valve.
7. Remove the drain hose.
IMPORTANT: Be sure the engine and exhaust system is cool before proceeding. The oil filter is located on the left side of the engine.
8. Place an absorbent shop cloth under the engine oil filter (D) to contain any spilled oil.
9. Turn the filter **counter-clockwise** to remove.
10. Apply a film of clean engine oil to the gasket of the new filter.
11. Install the new filter. Turn the filter **clockwise** until gasket makes contact with the mounting surface. Tighten 1/2 to 3/4 turn after gasket contact.
12. Add engine oil (refer to engine operator's manual) in the fill tube (A, Figure 21) and check the amount of oil in the engine using the engine oil dipstick (B).

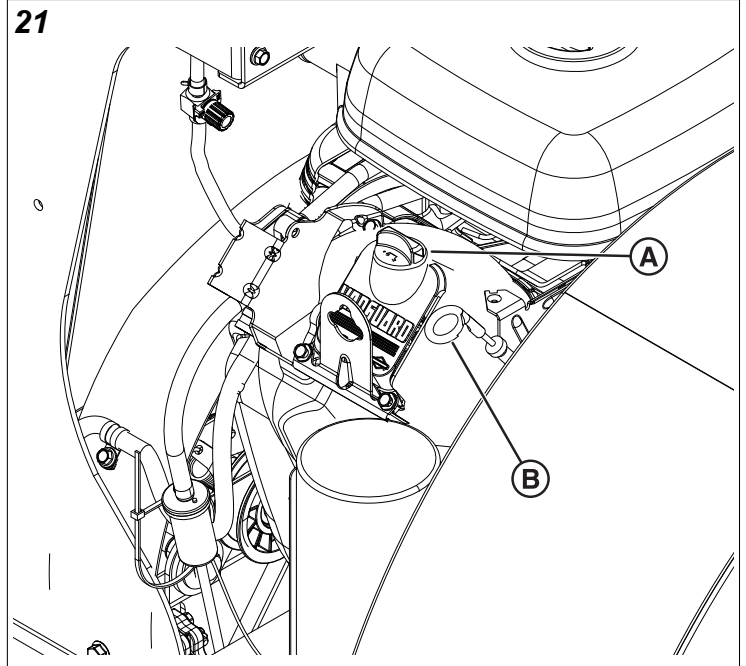

13. Remove the shop cloth and wipe up any spilled oil.

Clean the Engine Compartment Area with Pressurized Air and Water

Pressurized air and/or water can cause debris and/or hot water to be blown out. This action could result in personal injury.

When pressurized air and/or pressurized water is used for cleaning wear protective clothing, protective shoes, and eye protection. Eye protection includes goggles or a protective face shield.

The maximum air pressure for cleaning purposes must be below 205 kPa (30 psi). The maximum water pressure for cleaning purposes must be below 275 kPa (40 psi).

Engine Maintenance

For engine maintenance schedules and procedures, please refer to the engine operator's manual.

Containing Spilled Fluids and Proper Disposal of Waste

Make sure that fluids are contained when performing inspection, maintenance, testing, adjustment, and repair of the unit. Be prepared to collect the fluid with suitable leakproof containers before opening or disassembling any component containing fluids. Do not pour waste onto the ground, down a drain, or into any source of water.



Improper disposal of waste can threaten the environment. Dispose of all fluids according to local regulations and mandates.

Inspect Muffler and Spark Arrester

Inspect the muffler for cracks, corrosion, or other damage. Remove the spark arrester, if equipped, and inspect for damage or carbon blockage. If replacement parts are required, make sure to use only original equipment replacement parts.



WARNING

Replacement parts must be the same and installed in the same position as the original parts or fire could result.

Fuse Location and Identification

The electrical system for this unit is equipped with replaceable fuse(s). See the chart below for the circuit, amperage, and approximate location of the fuses.

Fits models: 5902130

Circuit	Amperage	Approximate Location
Main	30	Near engine.
Deflector Motor and Controls and Parking Brake	15 (resetable)	Control module mounted under the instrument control panel.

Fits models: 5902184

Circuit	Amperage	Approximate Location
Main	30	Near engine.
Deflector Motors and Controls	25	Control module mounted under the instrument control panel.
Parking Brake	10	

Checking Tire Pressures

Tire pressure should be checked periodically, and maintained at the levels shown in the Specifications chart. Note that these pressures may differ slightly from the "Max Inflation" stamped on the side-wall of the tires. The pressures shown provide proper traction and extend tire life.

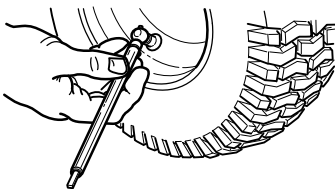

Check/Fill Transmission Oil Level

Oil Type: Mobil 1™ synthetic 15W-50 oil or equivalent.



CAUTION

Avoid injury! Escaping fluid under pressure can penetrate the skin causing serious injury. Avoid the hazard by relieving pressure before disconnecting hydraulic or other lines. Tighten all connection before applying pressure.

Search for leaks with a piece of cardboard. Protect hands and body from high pressure fluid.

This unit is equipped with two transmission oil tanks (A, Figure 22). One transmission oil tank only supplies oil to one transmission. The level of oil in both transmission tanks must be checked, and if necessary, filled.

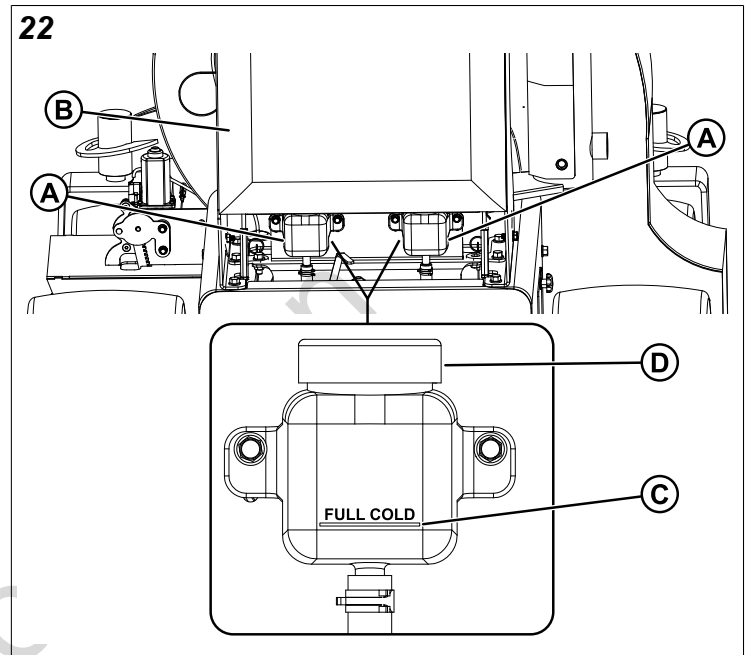

1. Locate the transmission oil tanks. The transmission oil tanks are located on the rear of the unit between the operator support cushion (B) and the engine.
2. Check the oil level when the unit is cold. The oil should be up to the "FULL COLD" mark (C) on the transmission oil tanks. If the oil is below this level, proceed to step #3.
3. Remove the operator support cushion from the unit.
4. Before removing the tank cap (D), make sure that the area around the tank caps and fill neck of the tank is free of dust, dirt, and other debris. Remove the tank caps.
5. Add oil up to the "FULL COLD" mark.
6. Install the tank caps.
7. Install the operator support cushion to the unit.
8. After adding oil to the tanks, it may be necessary to purge air from the hydraulic system. If the unit is not driving properly perform the *Purging the Air from the Hydraulic System* procedure

Changing Hydraulic Oil and Filter

Change Interval: Every 400 hours of yearly (Initial hydraulic oil and filter change after 75 hours of operation).

Filter Part Number: 5101026X1

1. Stop the unit on a flat, level surface and release the motion control levers. The levers will automatically pivot outwards and engage the parking brake. Close the deflectors, turn the ignition switch to OFF, and remove the key.
2. Allow the engine and transaxles to cool.
3. Raise the rear of the unit using a jack and use jack stands to secure the unit.
4. Remove both rear tires (A, Figure 23) from the unit.

23

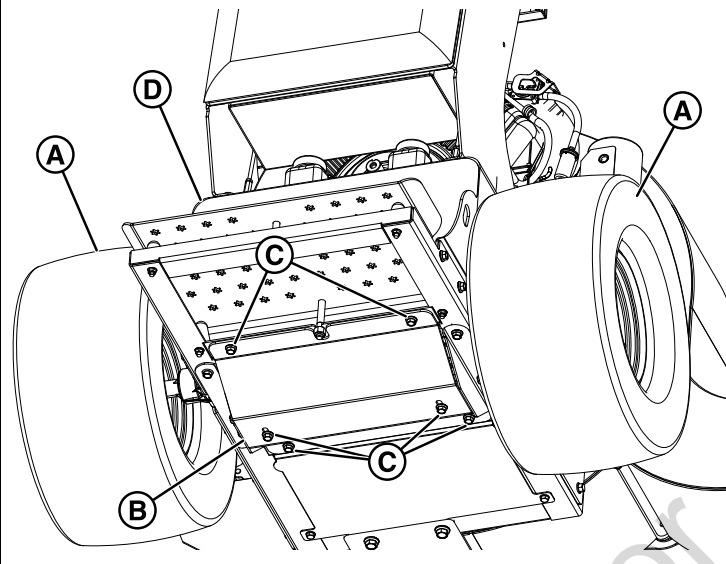

5. Position both hydraulic bypass valves in the bypass position.

CAUTION

Skid plate is heavy.

6. Position a jack underneath the skid plate (B) to support its weight as you remove it.
7. Remove the six (6) 3/8-16 X 3/4" bolts (C) that fasten the skid plate in position. Carefully lower the jack and remove the skid plate from the unit.
8. Remove the toe kick plate (D) to access the hydraulic filters and set aside.
9. Remove the three (3) filter guard screws (A, Figure 24) and filter guard (B) to access the oil filter. Clean any loose debris from around the perimeter of the filter. Place drain pan beneath the oil filter.

24

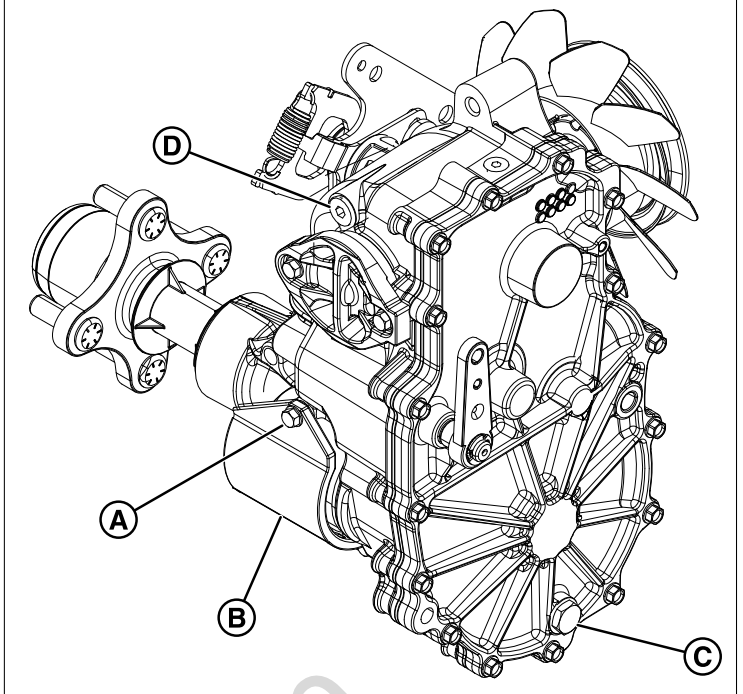

10. Remove the oil filter from the transaxle. Dispose of used filter properly.
11. Remove the drain plug (C) from the transaxle. Allow all fluid to drain.
12. After the oil has drained, wipe the filter base surface off and apply a film of new oil to the gasket of the new replacement filter.
13. Replace the drain plug.
14. Install the new filter by hand, turn 3/4 to one full turn after the filter gasket contacts the filter base surface. Do not use a wrench.
15. Re-install the filter guard with three screws. Torque screws to 65 in. lbs.
16. Repeat steps 9-15 on the opposite side transaxle drive.
17. Remove the purge port plug (D) from the back of the transaxle.
18. Remove the operator support cushion to access the hydraulic oil tanks.
19. Remove the caps from the hydraulic oil tanks, fill with Mobil 1™ 15W-50 or equivalent motor oil until oil just appears at the bottom of each transaxle's purge port (approximately 2.5 qts. per transaxle, 5 qts. total). Install the purge port plug into each transaxle as the oil level reaches this port.
20. Torque the purge port plugs to 180 in. lbs.
21. Continue to fill the transaxles through the expansion tank until the "FULL COLD" line is reached.
22. Install the expansion tank cap by hand. Be careful to not over tighten.
23. Install the operator support cushion

24. Perform the *Purging the Air from the Hydraulic System* Procedure.

Purging the Air from the Hydraulic System

Due to the effects air has on efficiency in hydraulic drive systems, it is critical that it be purged from the system. These purge procedures should be implemented any time a hydraulic system has been opened to facilitate maintenance or any additional oil has been added to the system.

The resulting symptoms of air in the hydraulic system may be:

- Noisy operation.
- Lack of power or drive after short term operation.
- High operation temperature and excessive expansion of oil.

Before starting, make sure the transaxles/transmissions are at the proper oil levels. If they are not, fill to the specifications outlined in the *Check/Fill Transmission Oil Level* procedure.

Purging Air from the Hydraulic System:

1. Chock the front wheels to prevent the unit from rolling. Raise the rear of the unit so that the unit's drive tires do not contact the ground. Position jack stands under the rear of the unit to secure it.
2. Open the transaxle's bypass valves (see *Pushing the Unit by Hand* for the location and function of the bypass valves), start the engine, release the parking brake, and slowly move the unit's motion control levers in both forward and reverse directions (5 to 6 times). As air is purged from the unit, the oil level will drop.
3. Stop the engine and engage the parking brake.
4. Close the transaxle's bypass valves, start the engine, release the parking brake, and slowly move the unit's motion control levers in both forward and reverse directions (5 to 6 times). As air is purged from the unit, the oil level will drop.
5. Stop the engine. Remove the jack stands from underneath the unit.
6. Repeat the process detailed above but with the unit's drive wheels on the ground. The procedure should be performed in an area free of any objects or bystanders.

It may be necessary to repeat the process detailed above until all the air is completely purged from the system. When the transaxles/transmissions operate at normal noise levels and move smoothly forward and reverse at normal speeds, then the transaxles/transmissions are considered purged.

Inspect/Remove Impeller



CAUTION

Be careful when removing the impeller. The impeller is heavy and there is not enough room for your fingers in the opening with the impeller. Hold onto the impeller by the fins using gloves to remove from the housing.

1. Stop the unit on a flat, level surface and release the motion control levers. The levers will automatically pivot outwards and engage the parking brake. Close the deflectors, turn the ignition switch to OFF, and remove the key.
2. Allow the machine to cool.
3. Remove the six (6) bolts (A, Figure 25) and the front safety cover (B).

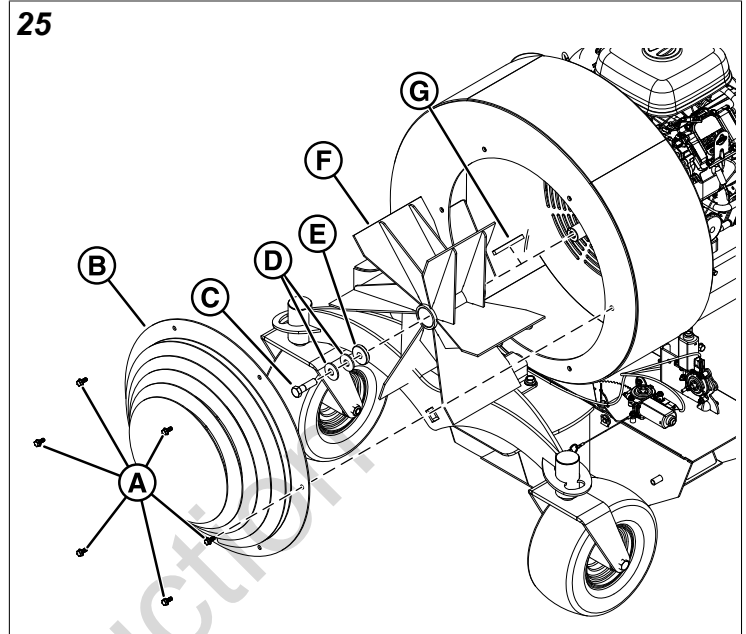

4. Remove the impeller bolt (C), two belleville washers (D), and 5/8" spacer (E).
5. Inspect the impeller (F) for cracks or damage. Replace the impeller if any damage is found. Contract your local dealer for original equipment replacement parts.
6. Inspect the impeller key (G). Replace if damaged.
7. Install the impeller, the 5/8" spacer, and the two (2) belleville washers (with their domes facing away from the impeller) onto the engine shaft.
8. When installing the impeller bolt, be sure it is clean of all oil. Use red Loctite® and torque the impeller bolt to 80 ft-lbs.
9. Install the front safety cover using the six (6) bolts.

Change Drive Belt

1. Stop the unit on a flat, level surface and release the motion control levers. The levers will automatically pivot outwards and engage the parking brake. Close the deflectors, turn the ignition switch to OFF, and remove the key.
2. Allow the unit to cool.
3. Remove the two (2) 5/16" bolts and nuts (A, Figure 26) and the belt guard (B) from the unit.

26

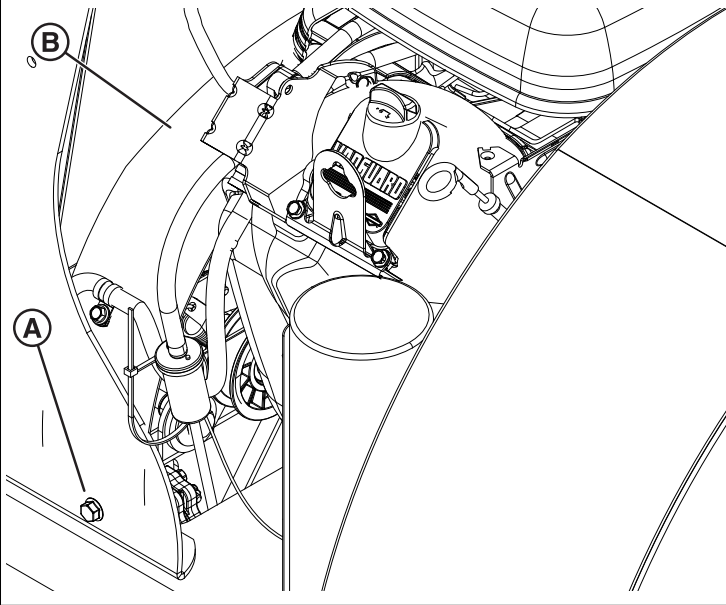

WARNING

Use extreme caution when rotating the idler arm with the tool due to the increased tension in the spring as the idler arm is being rotated. Injury may result if the tool is prematurely released while the spring is under tension.

- Place a 3/4" wrench (A, Figure 27) on the nut of the adjustable idler pulley (B) and rotate the idler arm in a direction that stretches the tension spring. This will relieve the pressure on the belt (C).

27

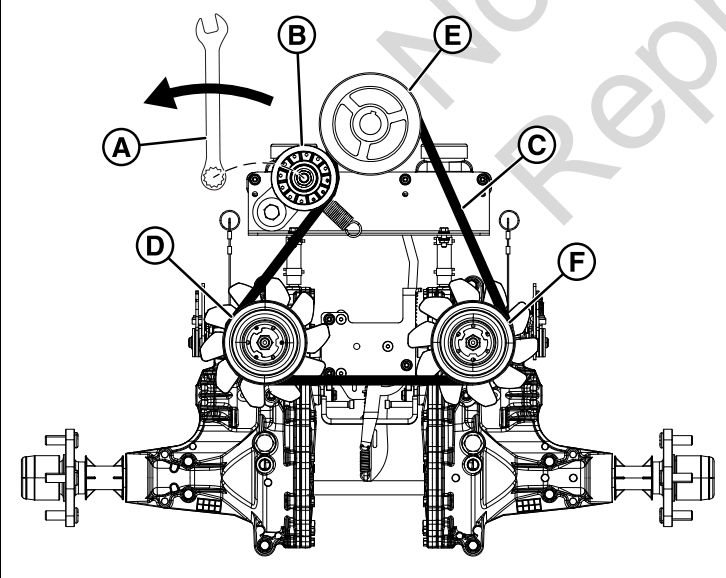

- Remove the belt from the right hand side transaxle pulley (D) then the adjustable idler pulley and then carefully allow the adjustable idler pulley to rotate back into place.
- Remove the belt from the engine drive pulley (E) and the left hand side drive pulley (F).

- Install the new belt so that the V-side of the belt goes into the pulley grooves of the engine drive pulley and the left hand side transaxle pulley.
- Place a 3/4" wrench on the nut of the adjustable idler pulley and rotate the idler arm in a direction that stretches the tension spring.
- Install the V-side of the belt into the pulley grooves of the right side transaxle pulley and that the flat side of the belt contacts the adjustable idler pulley. Carefully allow the adjustable idler pulley to rotate back into place.
- Install the belt guard using the two (2) 5/16" bolts and nuts.

Service Parking Brake

There is no serviceable brake adjustment. The brakes are automatic on this unit.

Adjust the Position of the Motion Control Levers

- Stop the unit on a flat, level surface and release the motion control levers. The levers will automatically pivot outwards and engage the parking brake. Close the deflectors, turn the ignition switch to OFF, and remove the key.
- Allow the engine to cool.
- Chock the front wheels of the unit.
- Press down on both motion control levers to release the parking brake.
- Move both motion control levers (A, Figure 28) to fully forward towards the front stationary handle bar (B).

28

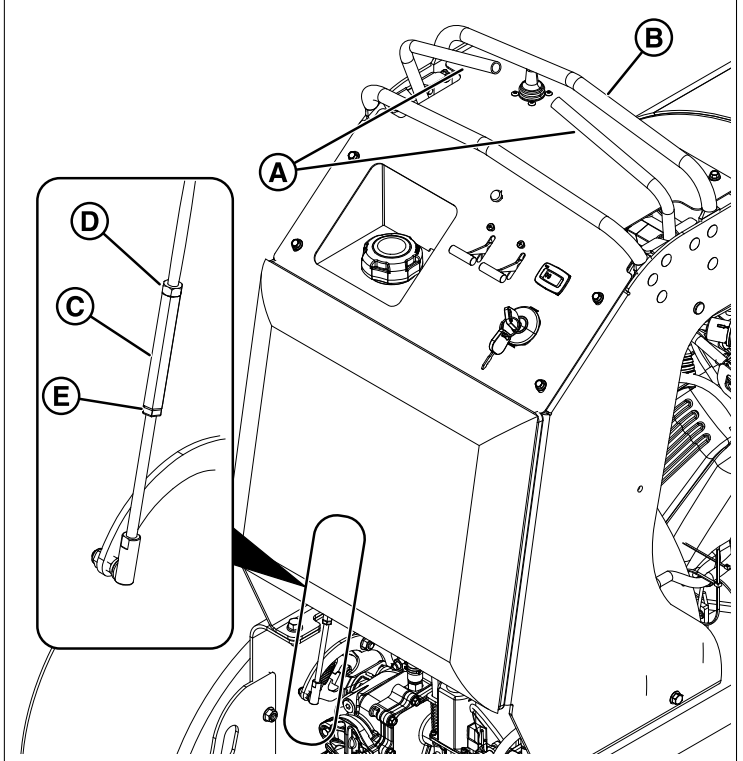

- There should be exactly 1/16" between the control levers and the handle bar. If the distance is great than 1/16" or the handles touch the handle bar then adjustment is needed.
- There are adjusters (C) located by the transaxles on the back of the unit, just below the gas tank on the left and right side of the unit. Loosen the two jam nuts (D & E) on the top and the bottom of the adjuster.

Note: The top jam nuts (D) are left hand threaded and the bottom jam nuts (E) are right hand threaded.

- Holding the lever fully forward to the handle bar, rotate the adjuster to get the 1/16" clearance measurement and then tighten the jam nuts. Repeat for the other side of the unit.

Neutral Adjustment

The neutral system for this unit is a function of the transaxles.

- Stop the unit on a flat, level surface such as a concrete floor and release the motion control levers. The levers will automatically pivot outwards and engage the parking brake.
- Pivot the handles down to release the parking brake while making sure you keep them in the NEUTRAL position and have not moved them forward or backwards. If the unit moves, the neutral system on the transaxles are not adjusted correctly. **See your dealer for service.**

Deflector Control and Motor Output Test Procedure

This unit is equipped with a control module (A, Figure 29), located under the instrument control panel, that is equipped with an LED light (B) and features a test mode with two stages that helps troubleshoot the electrical system for the deflector control (C), control module, and the deflector motor operations.

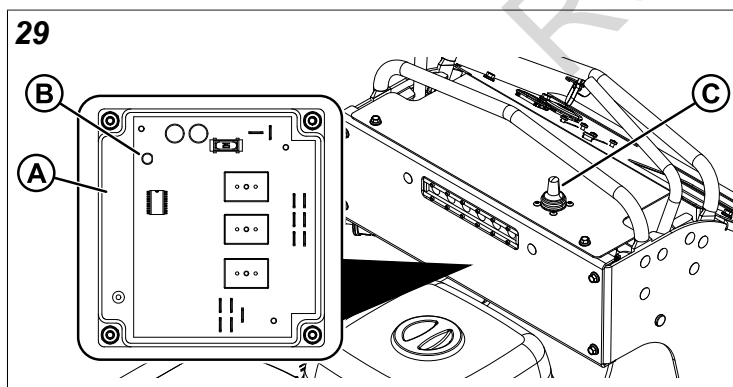

The purpose of these tests is to verify that the deflector components are working correctly.

Deflector Control and Motor Output Test

While performing this test you will need to be able to view the LED light to count the number of flashes.

- While holding the deflector control FORWARDS turn the ignition key to the RUN position. The LED light will blink rapidly to show the test mode has begun.
- Release the deflector control. The LED light will blink slowly.
Note: The LED light will blink slowly whenever the deflector control is in the neutral from now until you finish the action described in step # 6.
- Push and hold the deflector control FORWARDS. The LED light flashes single blinks as long as the deflector control is held.
Note: Holding the deflector control in any direction for ten (10) seconds will initiate the *Deflector Operation* test.
- Push and hold the deflector control BACKWARDS. The LED light flashes two (2) blinks as long as the deflector control is held.
- Push and hold the deflector control to the LEFT. The LED light flashes three (3) blinks as long as the deflector control is held.
- Push and hold the deflector control to the RIGHT. The LED light flashes four (4) blinks and then turns OFF.
- This completes this phase of the test.
- After you have completed the deflector control phase of the test you must perform the *Deflector Operation Test*.

Deflector Operation Test

This test will cycle the deflectors as they open and close. You must be in a position to observe the deflector motors to ensure that they are functioning.

It takes approximately 2-1/2 seconds for a deflector to fully travel in either direction. If a deflector motor cycles for five (5) seconds the motor will timeout. A motor that times out must be inspected for damage.

- Press the deflector control in any direction for ten (10) seconds and then release when the deflector motors begin to automatically cycle in the following order:
 - Left deflector OPENS.
 - Left deflector CLOSES.
 - Front deflector OPENS.
 - Front deflector CLOSES.
 - Right deflector OPENS.
 - Right deflector CLOSES.
- After the RIGHT deflector closes the tests are complete and the deflector control will reboot to normal operation mode.

Clean the Battery and Cables

This unit is equipped with a maintenance free BCIU1 battery.



WARNING

Keep open flames and sparks away from the battery.

- Be careful when handling the battery.
 - Avoid spilling electrolyte.
 - Keep flames and sparks away from the battery.
 - When removing or installing battery cables, disconnect the negative cable FIRST and reconnect it LAST. If not done in this order, the positive terminal can be shorted to the frame by a tool.
1. Stop the unit on a flat, level surface and release the motion control levers. The levers will automatically pivot outwards and engage the parking brake. Close the deflectors, turn the ignition switch to OFF, and remove the key.
 2. Use a floor jack to lift the right rear of the unit so that the right hand drive tire can be removed.
 3. Remove the right hand rear tire.
 4. Remove the battery cover (A, Figure 30) and retaining hardware (B) to access the battery (C).

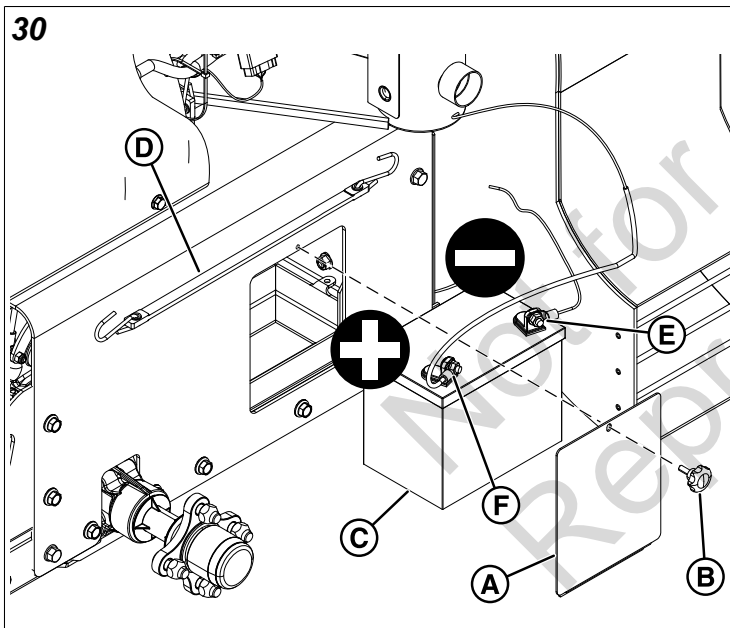

5. Remove the rubber strap (D) that holds the battery in place
6. Disconnect the cables from the battery, negative [-] cable first (E).
7. Remove the battery from the battery tray.
8. Clean the battery terminals and cable ends with a wire brush until shiny.

9. Put the battery in the battery tray and attach the battery cables, positive [+] cable first (F).
10. Put petroleum jelly or non-conducting grease on the cable ends and battery terminals.
11. Secure the battery with the rubber strap.
12. Install the battery cover.
13. Install the right hand rear tire.
14. Remove the floor jack from under the unit.

Battery Service



WARNING

Keep open flames and sparks away from the battery; the gasses coming from it are highly explosive. Ventilate the battery well during charging.

Checking Battery Voltage

A voltmeter can be used to determine condition of the battery. When the engine is off, the voltmeter shows battery voltage, which should be 12 volts. When the engine is running, the voltmeter shows voltage of charging circuit which normally is 13 to 14 volts.

A dead battery, or one too weak to start the engine, may not mean the battery needs to be replaced. For example, it may mean that the alternator is not charging the battery properly. If there is any doubt about the cause of the problem, see your authorized Billy Goat servicing dealer. If you need to replace the battery, follow the steps under *Cleaning the Battery and Cables*.

Charging the Battery



WARNING

Keep open flames and sparks away from the battery; the gasses coming from it are highly explosive. Ventilate the battery well during charging.

A dead battery or one too weak to start the engine may be the result of a defect in the charging system or other electrical component. If there is any doubt about the cause of the problem, see your authorized Billy Goat servicing dealer.

To charge the battery, follow the instructions provided by the battery charger manufacturer as well as all warnings included in the OPERATOR SAFETY section of this manual. Charge the battery until fully charged. Do not charge at a rate higher than 10 amps.

Jump Starting with Auxiliary (Booster) Battery

Jump starting is not recommended.

Troubleshooting

While normal care and regular maintenance will extend the life of your equipment, prolonged or constant use may eventually require that service be performed to allow it to continue to operating properly.

This troubleshooting guide lists the most common problems, their causes, and remedies.

Troubleshooting the Unit

FAILURE MODE	CAUSE OF PROBLEM	CORRECTIVE ACTION
Engine will not turn over or start.	Parking brake is not engaged.	Engage the parking brake.
	Out of fuel.	If engine is hot, allow it to cool, then add fuel to the fuel tank.
	Engine flooded.	Move choke control lever to the closed position.
	Blown fuse.	Replace fuse.
	Battery terminals are dirty.	Clean the battery terminals.
	Battery discharged or dead.	Charge or replace battery.
	Wiring loose or broken.	Visually check wiring and replace broken or frayed wires. Tighten any loosen connections.
	Safety interlock switch faulty.	Replace as needed. See authorized service dealer.
	Spark plug(s) faulty, fouled, or incorrectly gapped.	Clean and gap or replace. See engine owner's manual.
	Water in fuel.	Drain fuel and replace with fresh fuel.
	Gas is old or stale.	Drain fuel and replace with fresh fuel.
Engine starts hard or runs poorly.	Fuel mixture is too rich.	1. Clean air filter. 2. Check choke adjustment.
	Spark plug(s) faulty, fouled, or incorrectly gapped.	Replace as needed. See authorized service dealer.
	Fuel filter is plugged.	Replace fuel filter.
Engine knocks.	Low oil level.	Check/Add oil as required
	Using wrong grade oil	See engine owner's manual.
Excessive oil consumption.	Engine running too hot.	Clean engine fins, blower screen, and air cleaner.
	Using wrong weight engine oil.	See engine owner's manual.
	Too much oil in crankcase.	Drain excess oil.
Engine exhaust is black.	Dirty air filter.	Replace air filter. See engine owner's manual.
	Engine choke control lever is in closed position.	Move choke control lever to open position.
Oil alert light is illuminated.	Problem with engine.	Stop engine immediately and consult engine owner's manual.
Engine runs but unit will not drive.	Hydraulic Pump bypass valve(s) in bypass position.	Move hydraulic bypass valve(s) to run position.
	Drive belt is broken.	See <i>Change Drive Belt</i> .
	Drive belt is slipping.	See problem and cause below.
	Brake is not fully released.	See authorized service dealer.
Drive belt slips.	Pulleys or belt is greasy or oily.	Clean as required.

FAILURE MODE	CAUSE OF PROBLEM	CORRECTIVE ACTION
	Belt is stretched or worn.	Replace belt.
	Belt tension is too loose.	If belt has already been replaced with new belt, then replace tension spring.
Parking brake will not hold.	Brake is incorrectly adjusted.	See authorized service dealer.
Unit steers or handles poorly.	Motion control lever linkages are loose.	Check and tighten any loose connections.
	Improper tire inflation.	See <i>Specifications</i> for proper tire inflation and adjust tire pressures accordingly.

Troubleshooting the Blower

FAILURE MODE	CAUSE OF PROBLEM	CORRECTIVE ACTION
Excessive unit vibration	Engine speed is too low.	Increase engine speed.
	Drive belt is not tensioned correctly.	Adjust the belt tension. See <i>Change Drive Belt</i> .
	Impeller is out of balance.	Check impeller for damage, cracks, broken or bent fins. If damaged in any way, REPLACE IMPELLER.
Discharge deflectors not opening or closing.	Deflector switch broken or sticking.	Replace deflector switch. See authorized Service dealer.
	Electrical component malfunction.	Replace the affected component. See authorized Service dealer.
	Deflector motor damaged.	Replace deflector motor. See authorized Service dealer.

Not for
Reproduction

Specifications

Specifications are correct at time of printing and are subject to change without notice.

ENGINE

For complete engine specifications see the engine manufacturer's operator's manual included with your unit.

Fits models: 5902130 & 5902184

Briggs & Stratton Engine	
Make	Briggs & Stratton
Model	386447-0403-G1
Electrical System	12 volt, 16 amp alternator; Battery: 340 CCA
Engine RPM High Setting	3220+/- 20 rpm with all deflector plates closed.

CHASSIS

Fuel Tank Capacity	10 gallons (38 L) total
Rear Wheels	

Tire Size	20 X 8.00 - 8
Inflation Pressure	22 psi (1,5 bar)
Front Wheels	
Tire Size	11 X 4 - 5
Inflation Pressure	N/A (flat free tire)

TRANSMISSIONS

Make	Hydro-Gear®
Model	ZT3100 Transaxles
Hydraulic Fluid	Mobil 1™ 15W-50 synthetic or equivalent
Speed	Infinitely Variable

DIMENSIONS

Width	41-1/2" (105 cm)
Height	54-3/4" (139 cm)
Length	61" (155 cm)
Weight	749 lbs (340 kg)

Not for
Reproduction

Warranty Statement

BRIGGS & STRATTON WARRANTY POLICY (April 2021)

LIMITED WARRANTY

Briggs & Stratton warrants that, during the warranty period specified below, it will repair or replace, free of charge, any part that is defective in material or workmanship or both. Transportation charges on product submitted for repair or replacement under this warranty must be borne by purchaser. This warranty is effective for and is subject to the time periods and conditions stated below. For warranty service, find the nearest Authorized Service Dealer in our dealer locator map at billygoat.com. The purchaser must contact the Authorized Service Dealer, and then make the product available to the Authorized Service Dealer for inspection and testing.

There is no other express warranty. Implied warranties, including those of merchantability and fitness for a particular purpose, are limited to the warranty period listed below, or to the extent permitted by law. Liability for incidental or consequential damages are excluded to the extent exclusion is permitted by law. Some states or countries do not allow limitations on how long an implied warranty lasts, and some states or countries do not allow the exclusion or limitation of incidental or consequential damages, so the above limitation and exclusion may not apply to you. This warranty gives you specific legal rights and you may also have other rights which vary from state to state or country to country.**

WARRANTY PERIOD		
Item	Standard Warranty Period	Rental Warranty Period
Ride On Debris Blower	2 years (24 months) / unlimited hours	1 year
+Belts, Tires, Hoses, Battery, Switches, Bearings, Electrical Components	90 days	90 days
+Attachments	1 year	90 days
+Engine*	See Engine Operator's Manual	See Engine Operator's Manual

* Emissions-related components are covered by the Emissions Warranty Statement

** In Australia - Our goods come with guarantees that cannot be excluded under the Australian Consumer Law. You are entitled to a replacement or refund for a major failure and for compensation for any other reasonably foreseeable loss or damage. You are also entitled to have the goods repaired or replaced if the goods fail to be of acceptable quality and the failure does not amount to a major failure. For warranty service, find the nearest Authorized Service Dealer in our dealer locator map at billygoat.com (Select region: Australia), or by calling 1300 274 447, or by emailing or writing to salesenquires@briggsandstratton.com.au, Briggs & Stratton Australia Pty Ltd, 1 Moorebank Avenue, NSW, Australia, 2170.

The warranty period begins on the date of purchase by the first retail or commercial customer.

To ensure prompt and complete warranty coverage, register your product at the website shown above or at www.onlineproductregistration.com, or mail the completed registration card (if provided), or call 1-800-776-7690 (in USA).

Save your proof of purchase receipt. If you do not provide proof of the initial purchase date at the time warranty service is requested, the manufacturing date of the product will be used to determine the warranty period. Product registration is not required to obtain warranty service on Briggs & Stratton products.

ABOUT YOUR WARRANTY

Warranty service is available only through *Billy Goat* Authorized Service Dealers. This warranty only covers defects in materials or workmanship. It does not cover damage caused by improper use or abuse, improper maintenance or repair, normal wear and tear, or stale or unapproved fuel.

Improper Use and Abuse - The proper, intended use of this product is described in the Operator's Manual. Using the product in a way not described in the Operator's Manual or using the product after it has been damaged will not be covered under this warranty. Warranty coverage will also not be provided if the serial number on the product has been removed or the product has been altered or modified in any way, or if the product has evidence of abuse such as impact damage, or water/chemical corrosion damage.

Improper Maintenance or Repair - This product must be maintained according to the procedures and schedules provided in the Operator's Manual, and serviced or repaired using genuine Briggs & Stratton parts or equivalent. Damage caused by lack of maintenance or use of non-original or non-equivalent parts is not covered by warranty.

Normal Wear and Tear - Like all mechanical devices, the unit is subject to wear even when properly maintained. This warranty does not cover replacement or repairs when normal use has exhausted the life of a part or the equipment. Except as noted in the warranty period, maintenance and wear items such as filters, belts, cutting blades, and brake pads (except engine

brake pads) are not covered by warranty due to wear characteristics alone, unless the cause is due to defects in material or workmanship.

Stale or Unapproved Fuel - In order to function correctly, this product requires fresh fuel that conforms to the criteria specified in the Operator's Manual. Engine or equipment damage caused by stale fuel or the use of unapproved fuels (such as E15 or E85 ethanol blends) is not covered by warranty.

Other Exclusions - This warranty excludes damage due to accident, abuse, modifications, alterations, improper servicing, freezing or chemical deterioration. Attachments or accessories that were not originally packaged with the product are also excluded. This warranty does not include used, reconditioned, second-hand, or demonstration equipment or engines. This warranty also excludes failures due to acts of God and other force majeure events beyond the manufacturer's control.

5421991 Revision A

Evaporative Emissions Warranty

For details on the Evaporative Emissions Control System Warranty, contact your Billy Goat Authorized Service Dealer to start Evaporative Emissions Warranty service or refer to the Evaporative Emissions Control System Warranty statement located at billygoat.com. The warranty can be located by typing "Emissions Warranty" in the FAQ or by calling 1-800-444-7774. For Exhaust Emissions Control System Warranty related to the engine refer to the engine operator's manual.

Not for
Reproduction

