



Owner's Manual

for V-Blade and Straight-Blade Snowplows

© 2023—BOSS Products
2010 The BOSS Way
Iron Mountain, MI 49801

Register at www.bossplow.com.



Original Instructions (EN)
Printed in the USA
All Rights Reserved



Introduction

Note: This manual is used for the operation and maintenance of all BOSS truck plows. Illustrations may vary.

Read this information carefully to learn how to operate and maintain your product properly and to avoid injury and product damage. You are responsible for operating the product properly and safely.

Visit www.BOSSPlow.com for product safety and operation training materials, accessory information, help finding a dealer, or to register your product.

Whenever you need service, genuine BOSS parts, or additional information, contact an Authorized BOSS Dealer or BOSS Technical Service (1-800-286-4155) and have the model and serial numbers of your product ready. [Figure 1](#) identifies the location of the model and serial numbers on the product. Write the numbers in the space provided.

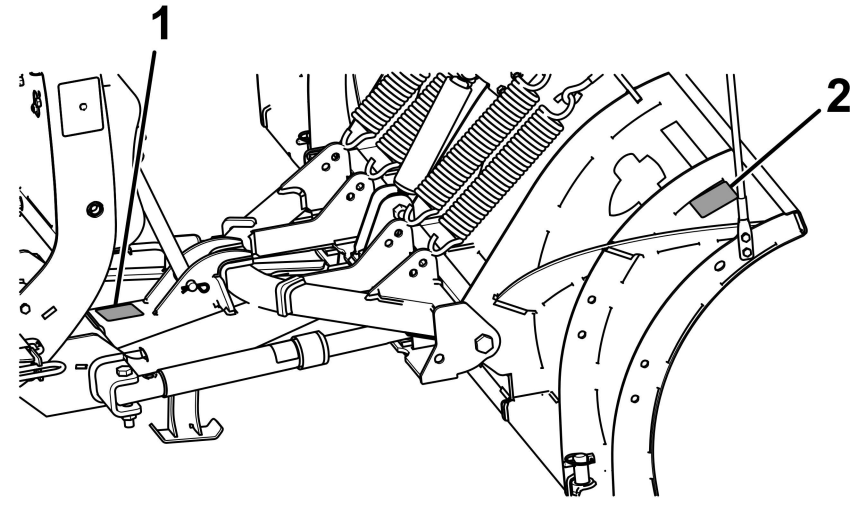
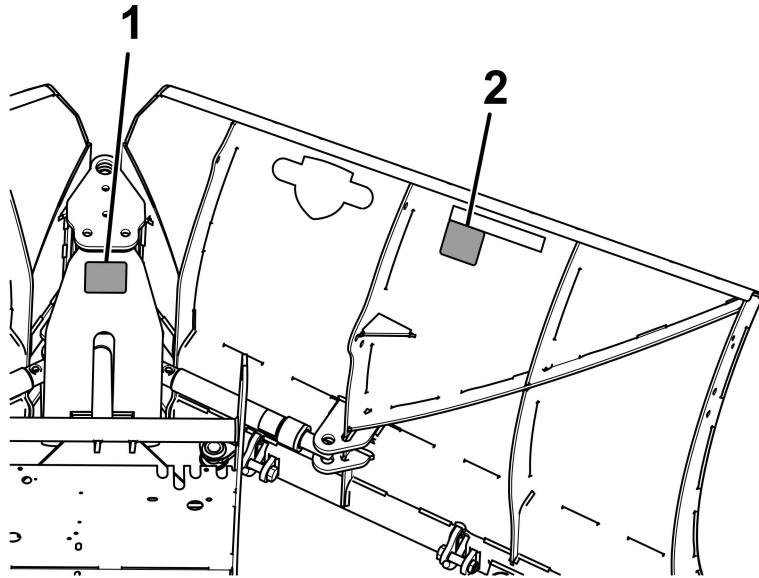

Figure 1

g230525

1. Blade crate serial number location

2. Model and serial number location

Date Purchased	_____
Model No.	_____
Serial No.	_____
Blade Crate Serial No.	_____

This manual identifies potential hazards and has safety messages identified by the safety-alert symbol (Figure 2), which signals a hazard that may cause serious injury or death if you do not follow the recommended precautions.



Figure 2

g000502

1. Safety-alert symbol

This manual uses 2 words to highlight information. **Important** calls attention to special mechanical information and **Note** emphasizes general information worthy of special attention.

This product complies with all relevant European directives; for details, please see the separate product specific Declaration of Conformity (DOC) sheet.

BOSS Products limited consumer warranty and BOSS Products commercial warranty policies are located at www.BOSSPlow.com.

Patent www.ttcopats.com.

Contents

Safety	7
Preparation.....	7
Operation.....	8
Product Overview	13
V-Blade Plows	13
V-Blade Controls.....	14
Straight-Blade Plows	18
Straight-Blade Controls.....	20
EXT Straight-Blade Controls.....	24
Specifications	28
Attachments/Accessories	29
Operation.....	30
Before Operation	30
Mounting the Snowplow	32
Checking the Hydraulic Fluid Level	36
Adding Hydraulic Fluid	37
During Operation	38
Protecting Your Transmission	38
Plowing Parking Lots	39
Plowing Driveways.....	40
Operating Tips	41
After Operation	42
Removing the Snowplow	42

Maintenance	46
Recommended Maintenance Schedule(s)	47
Hydraulic System Maintenance	48
Draining the Hydraulic Fluid	48
Adding Hydraulic Fluid	49
Adjusting the Hydraulic Lowering Speed	51
Checking the Hydraulic Lines and Hoses	52
Miscellaneous Maintenance	53
Adjusting the Pushbeam Height.....	53
Setting Express Raise Mode.....	54
Setting Heavy-Duty Mode	54
Leveling the Plow Blades	55
Adjusting the Angle of Attack	58
Replacing the Torsion Springs	59
Replacing the Trip Bar	62
Adjusting the Aim of the Plow Headlights	63
Storage	65
Storing the Plow	65
Removing the Plow from Storage	66

Safety

Improper use or maintenance by the operator or owner can result in injury. To reduce the potential for injury, comply with these safety instructions and always pay attention to the safety-alert symbol **▲**, which means *Caution, Warning, or Danger*—personal safety instruction. Failure to comply with the instruction may result in personal injury or death.

Preparation

- Read the *Owner's Manual* before operating or servicing the plow.
- Always follow the vehicle manufacturer's recommendations relating to snowplow installation. For recommended vehicle models, refer to the BOSS product selector tool at www.BOSSPlow.com.
- Ensure that only trained personnel install and perform maintenance on the equipment and hydraulic components.
- Never disable, remove, or relocate any sensors or other components related to the operation of the air bags in your vehicle.
- Keep your hands, feet, and clothing away from moving parts and mounting points.
- Ensure the plow is properly attached to the vehicle before moving it.
- To comply with federal regulations and to assure a safe vehicle, do not exceed the front gross-axle-weight rating (FGAWR), rear gross-axle-weight rating (RGAWR), and the gross-vehicle-weight rating (GVWR) at any time.
- Always wear appropriate personal protective equipment when operating and servicing the machine. Wear substantial, slip-resistant footwear, and cold-weather clothing.
- Use a 500 kg (1/2 ton) minimum lifting device to move heavy plow components.
- Material safety data sheets (MSDS) are available at www.BOSSPlow.com.

Operation

- Vehicles equipped with air bags are designed so that the air bags activate in a frontal collision equivalent to hitting a solid barrier (such as a wall) at approximately 22 km/h (14 mph) or more, or a frontal perpendicular collision with a parked car or truck of similar size at approximately 45 km/h (28 mph) or more. Careless or high-speed driving while plowing snow can deploy the air bag.
- When transporting the vehicle, position the plow so as not to block your vision or the plow headlights.
- Do not change the blade position when traveling.
- Do not exceed 64 km/h (40 mph) when transporting the plow.
- Do not exceed 22 km/h (14 mph) when plowing.
- Do not exceed 8 km/h (5 mph) when D-Force is activated (if equipped).
- Always lower the blade when the vehicle is not in use.
- Never put any part of your body between the plow and the vehicle.
- Do not operate the machine while ill, tired, or under the influence of alcohol or drugs.
- Use your full attention while operating the machine. Do not engage in any activity that causes distractions; otherwise, injury or property damage may occur.
- Always wear your seat belt while operating a motor vehicle.
- Due to the variety of equipment that you can install on the vehicle, do not exceed the front gross-axle-weight rating (FGAWR), rear gross-axle-weight rating (RGAWR), and the gross-vehicle-weight rating (GVWR) at any time. This may require weighing the vehicle and adding ballast as necessary. It may also limit the payload capacity of the vehicle.
- This machine has an operating sound level below 70 dBA.
- When transporting the machine, ensure that it is properly secured. Instructions are available at www.BOSSPlow.com.

Safety and Instructional Decals



Safety decals and instructions are easily visible to the operator and are located near any area of potential danger. Replace any decal that is damaged or missing.

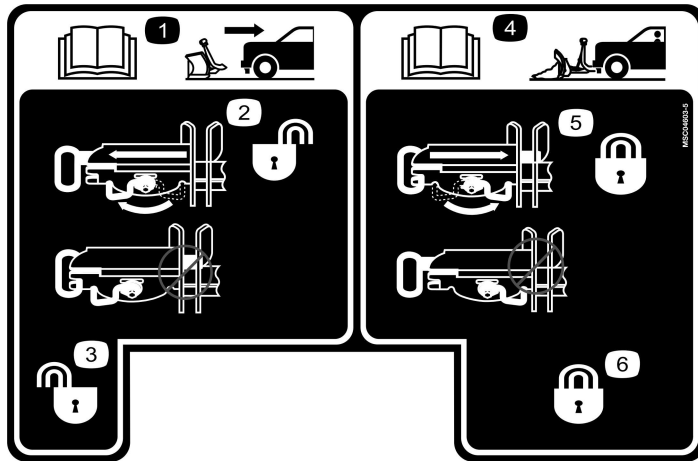

MSC04603-5

g230549

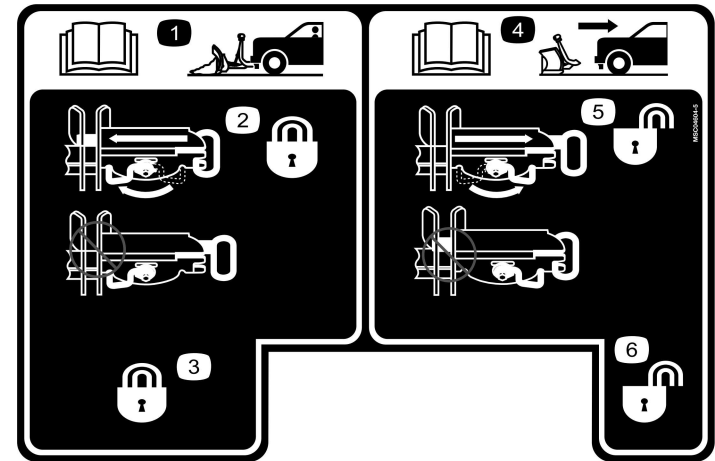

MSC04604-5

g230550

1. Read the *Owner's Manual* for information on removing the plow.
2. Coupler spring pin unlock
3. Coupler spring pin unlock

4. Read the *Owner's Manual* for information on attaching the plow.
5. Coupler spring pin lock
6. Coupler spring pin lock

1. Read the *Owner's Manual* for information on attaching the plow.
2. Coupler spring pin lock
3. Coupler spring pin lock

4. Read the *Owner's Manual* for information on removing the plow.
5. Coupler spring pin unlock
6. Coupler spring pin unlock

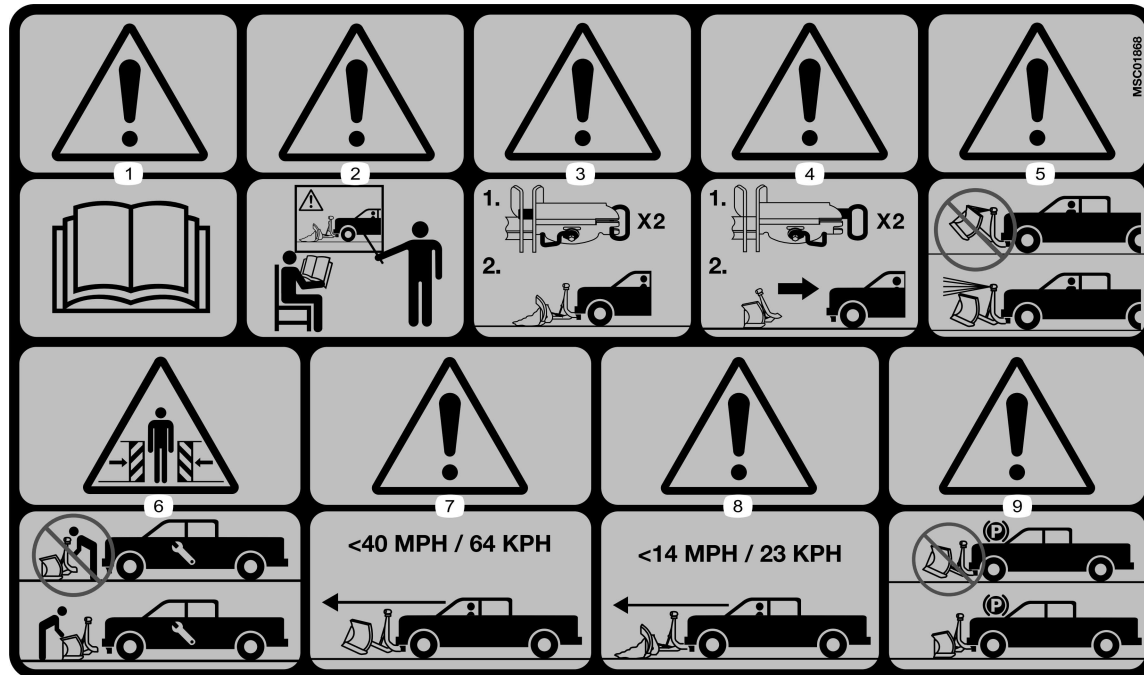

MSC01868

g230547

1. Warning—read the *Owner's Manual*.
2. Warning—all operators should be trained before operating the machine.
3. Warning—coupler spring pins must be locked before plowing.
4. Warning—coupler spring pins must be unlocked to remove the plow.
5. Warning—do not block the vehicle headlights with the plow.
6. Crushing hazard—do not stand between the plow and vehicle during maintenance.
7. Warning—do not exceed 64 km/h (40 mph) when transporting the plow.
8. Warning—do not exceed 22 km/h (14 mph) when plowing.
9. Warning—lower the plow when the vehicle is not in use.

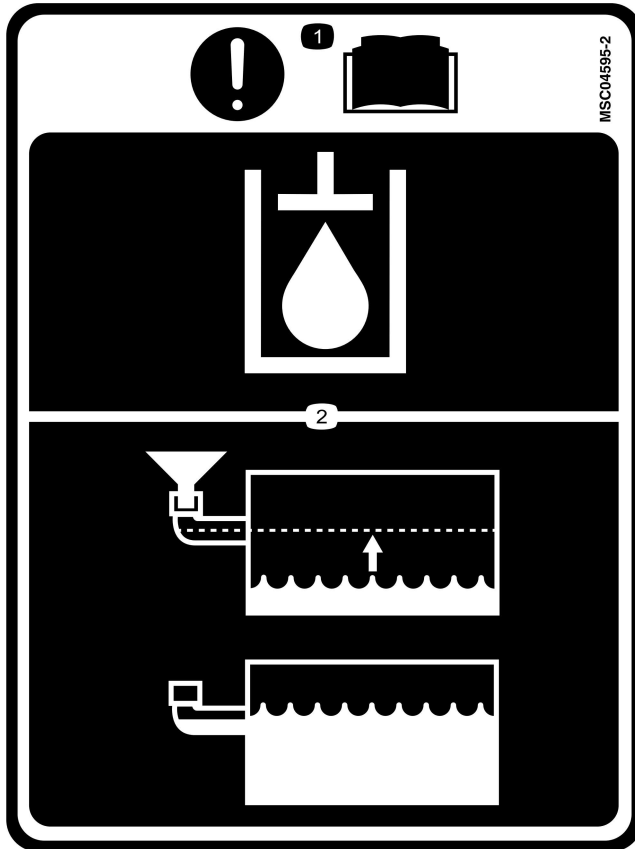

MSC04595

g230548

1. Important—read the *Owner's Manual*.
2. Fill the hydraulic fluid to the bottom of the fill elbow.

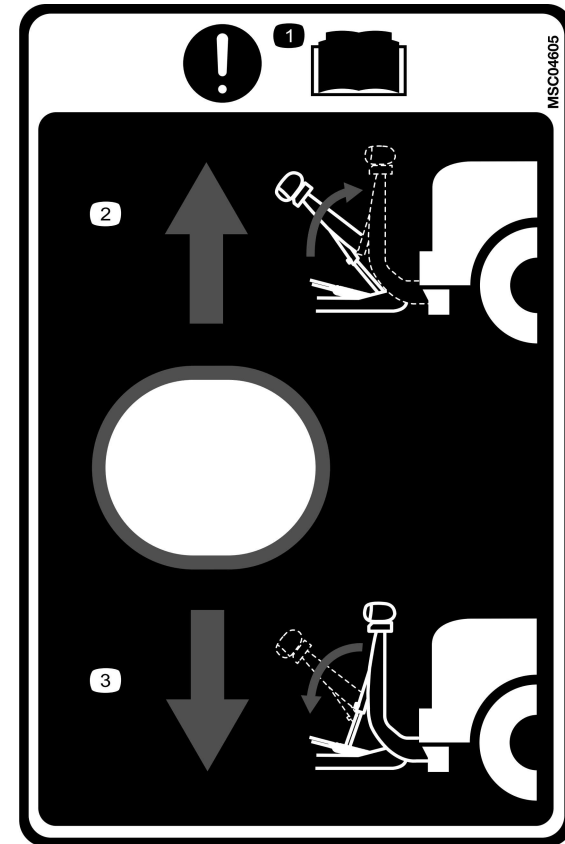

MSC04605

g230551

1. Important—read the *Owner's Manual*.
2. Raise the coupler tower.
3. Lower the coupler tower.

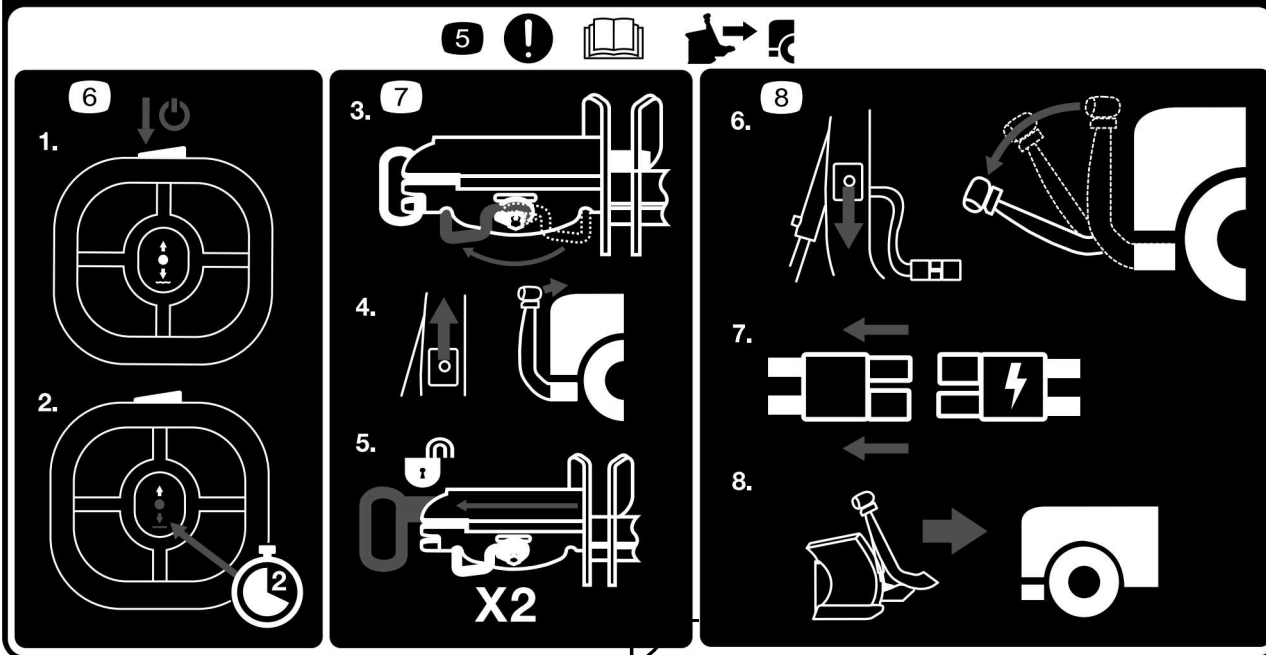
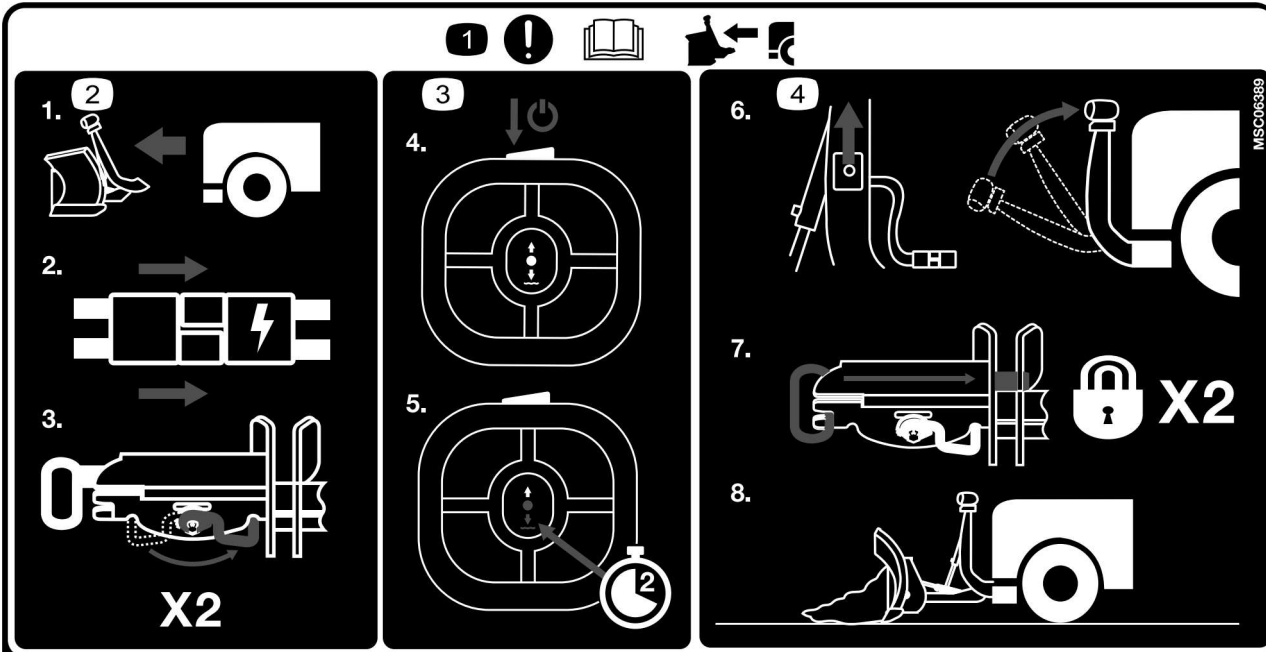

Product Overview

V-Blade Plows

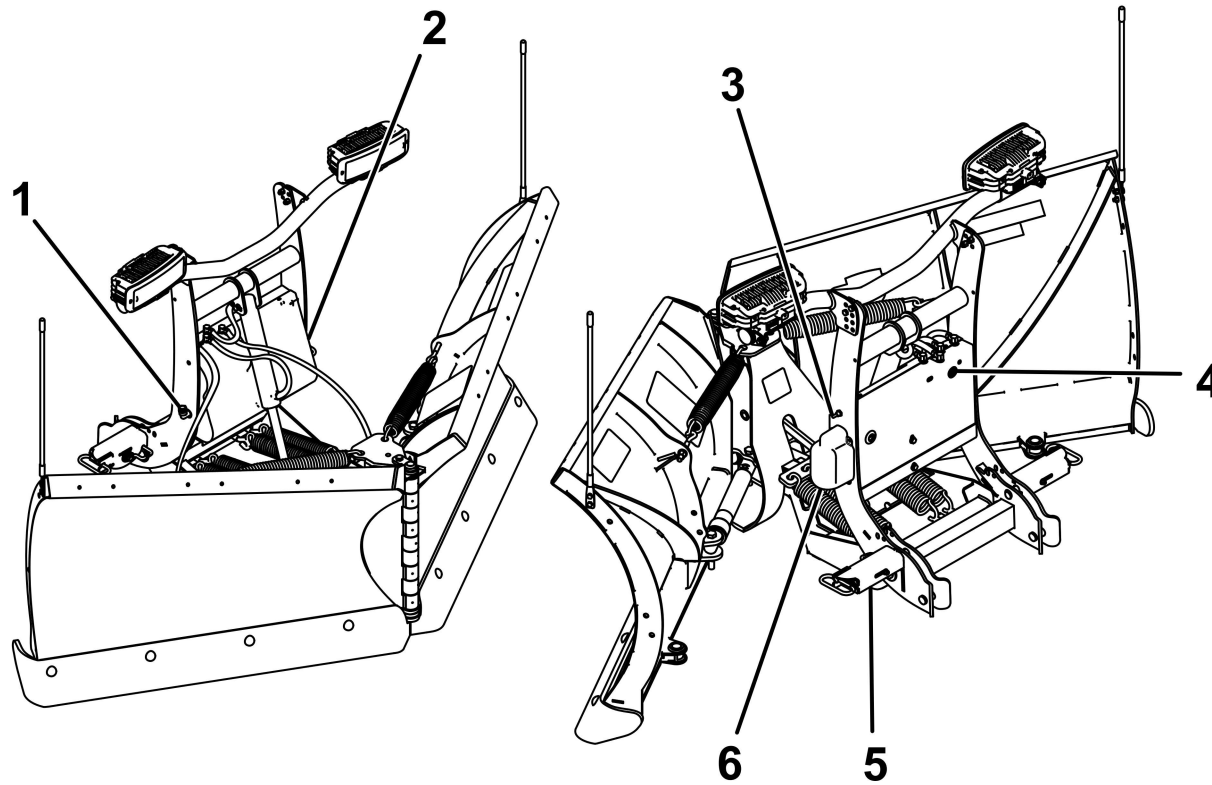

Figure 8

- | | | |
|-----------------------------------|---------------------------------|-----------------------------------|
| 1. Hydraulic reservoir fill elbow | 3. SmartHitch2 switch | 5. Spring pin |
| 2. Coupler-tower cover | 4. Hydraulic flow-control valve | 6. D-Force accumulator (optional) |

g285415

V-Blade Controls

Become familiar with all the controls before you operate the plow.

Joystick Controller

The joystick controller operates the movement of the snowplow. You can rotate the Raise/Lower switch for right or left hand operation by pulling up the joystick and rotating it to the desired position.

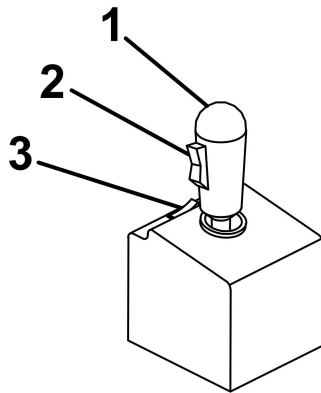

Figure 9

g230716

- 1. Joystick
- 2. Raise/Lower switch
- 3. On/Off switch

- On/Off switch—turns the plow controller on and off. A red light illuminates when the controller is on.
Note: Turn off the controller when not in use to prevent accidental activation of the plow.
- Raise/Lower switch—raises or lowers the plow blade. Press the switch up to raise the plow. Press the switch down to lower the plow.
- Directional joystick—controls the direction that the plow moves
 - To activate the Float feature, press the Raise/Lower switch down until it clicks into the detent position, allowing the plow blade to follow the contour of the ground. The switch stays in the Float position until it is pressed up again.
 - To move the right plow wing out, push the joystick diagonally right and forward.
 - To move the left plow wing out, push the joystick diagonally left and forward.
 - To make the scoop shape with the plow, move both wings out and push the joystick forward.

- To make the V shape with the plow, move both wings in and pull the joystick backward.
- To move the right plow wing in, pull the joystick diagonally right and backward.
- To move the left plow wing in, pull the joystick diagonally left and backward.
- To angle the entire plow blade right, move the right wing in, the left wing out, and push the joystick right.
- To angle the entire plow blade left, move the right wing out, the left wing in, and push the joystick left.

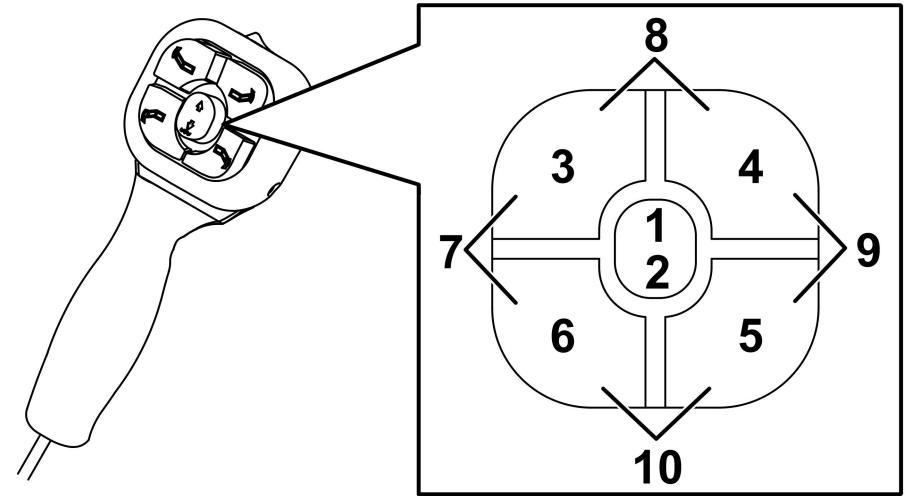

G033007
g033007

Figure 10

- | | |
|--------------------------|------------------------|
| 1. Raise button | 6. Left Wing In button |
| 2. Lower button | 7. Angle left |
| 3. Left Wing Out button | 8. Scoop |
| 4. Right Wing Out button | 9. Angle right |
| 5. Right Wing In button | 10. V |

SmartTouch2 Controller

The SmartTouch2 controller operates the movement of the snowplow.

Note: Plows equipped with D-Force must have a SmartTouch2 controller with a red center button.

- On/Off switch—turns the plow controller on and off. A green light illuminates when the controller is on.

Note: Turn off the controller when not in use to prevent accidental activation of the plow.

- Raise button—raises the plow blade. Pressing the button quickly twice automatically raises the blade when Express Raise mode is enabled; refer to [Setting Express Raise Mode \(page 54\)](#).
- Lower button—lowers the plow blade and activates the FLOAT and D-FORCE features.
 - FLOAT—double tapping the button or holding it for 2 seconds automatically lowers the blade and activates the FLOAT feature, allowing the plow blade to follow the contour of the ground. A red light illuminates when the FLOAT feature is active.
 - D-FORCE (optional)—if your plow is equipped with the D-FORCE feature, double tapping the button a second time activates it, applying a downward force on the blade to improve back blading. An orange light illuminates when the D-FORCE feature is active.

Note: You can only activate the D-FORCE feature twice before the plow must be raised.

Important: Use the D-Force feature only while back dragging to prevent damage to the plow or vehicle.

- Left Wing Out button—moves the left wing out
- Right Wing Out button—moves the right wing out
- Left Wing In button—moves the left wing in
- Right Wing In button—moves the right wing in
- Sleep mode—If you do not use the controller for 20 minutes, it enters sleep mode and the controller lights flash green and red. Turn the controller off and on again to deactivate the sleep mode.

To perform different tasks, you can configure the plow wings as follows:

- To angle the entire plow blade right, press the Right Wing In and Right Wing Out buttons simultaneously until the blades are fully angled.
- To angle the entire plow blade left, press the Left Wing In and Left Wing Out buttons simultaneously until the blades are fully angled.

- To make the scoop shape with the plow, press the Left Wing Out and Right Wing Out buttons simultaneously until the blades are fully extended.
- To make the “V” shape with the plow, press the Left Wing In and Right Wing In buttons simultaneously until the blades are fully retracted.

SmartHitch2 Switch

The SmartHitch2 switch controls the movement of the coupler tower to facilitate plow attachment and removal. With the controller in the Float mode, press the switch up to raise the tower and down to lower the tower.

Spring Pins

The spring pins secure the plow to the vehicle pushbeam. Turn the levers toward the coupler tower to lock the spring pins. Turn the levers away from the coupler tower to unlock the spring pins.

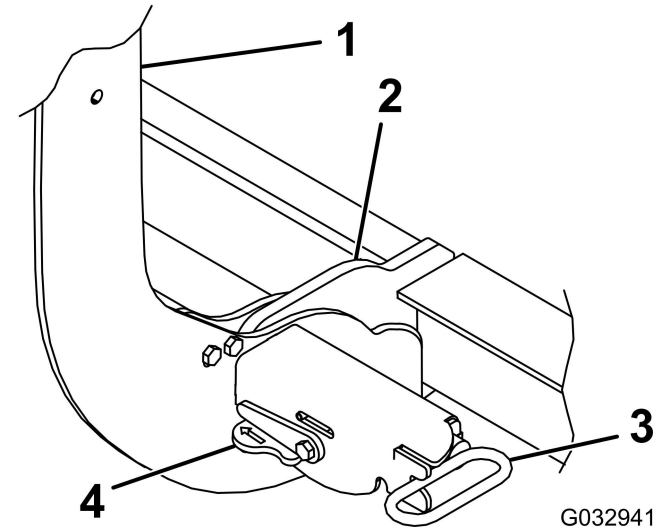

Figure 11

- | | |
|------------------|---------------|
| 1. Coupler tower | 3. Spring pin |
| 2. Pin receiver | 4. Lever |

Headlight Toggle Switch

The headlight toggle switch controls which set of headlights is being used. Move the switch to the TRUCK position to use the headlights on the vehicle. Move the switch to the PLOW position to use the headlights on the plow.

Straight-Blade Plows

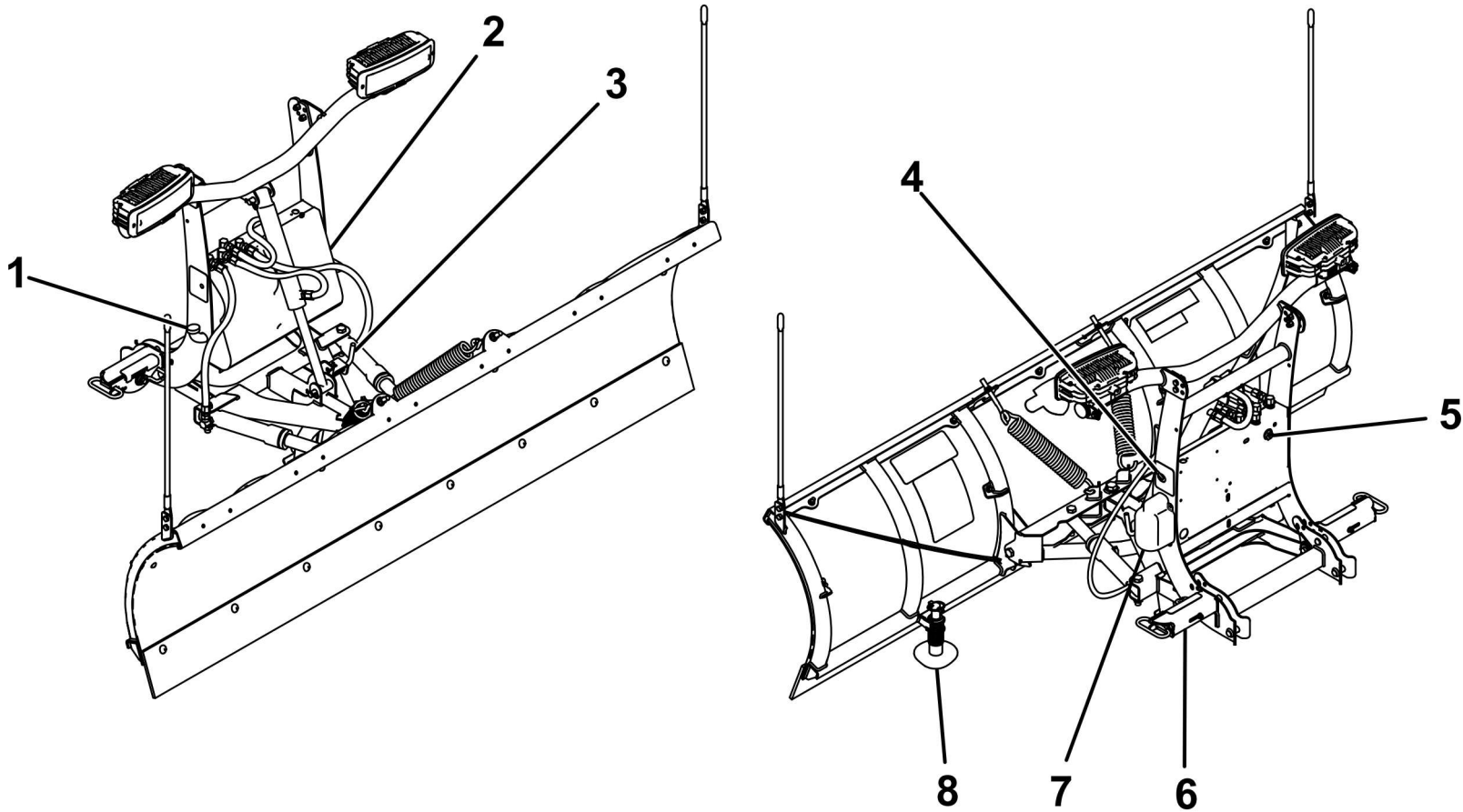

Figure 12

g230574

- | | | |
|-----------------------------------|---------------------------------|-----------------------------------|
| 1. Hydraulic reservoir fill elbow | 4. SmartHitch2 switch | 7. D-Force accumulator (optional) |
| 2. Coupler-tower cover | 5. Hydraulic flow-control valve | 8. Plow shoe |
| 3. Kickstand | 6. Spring pin | |

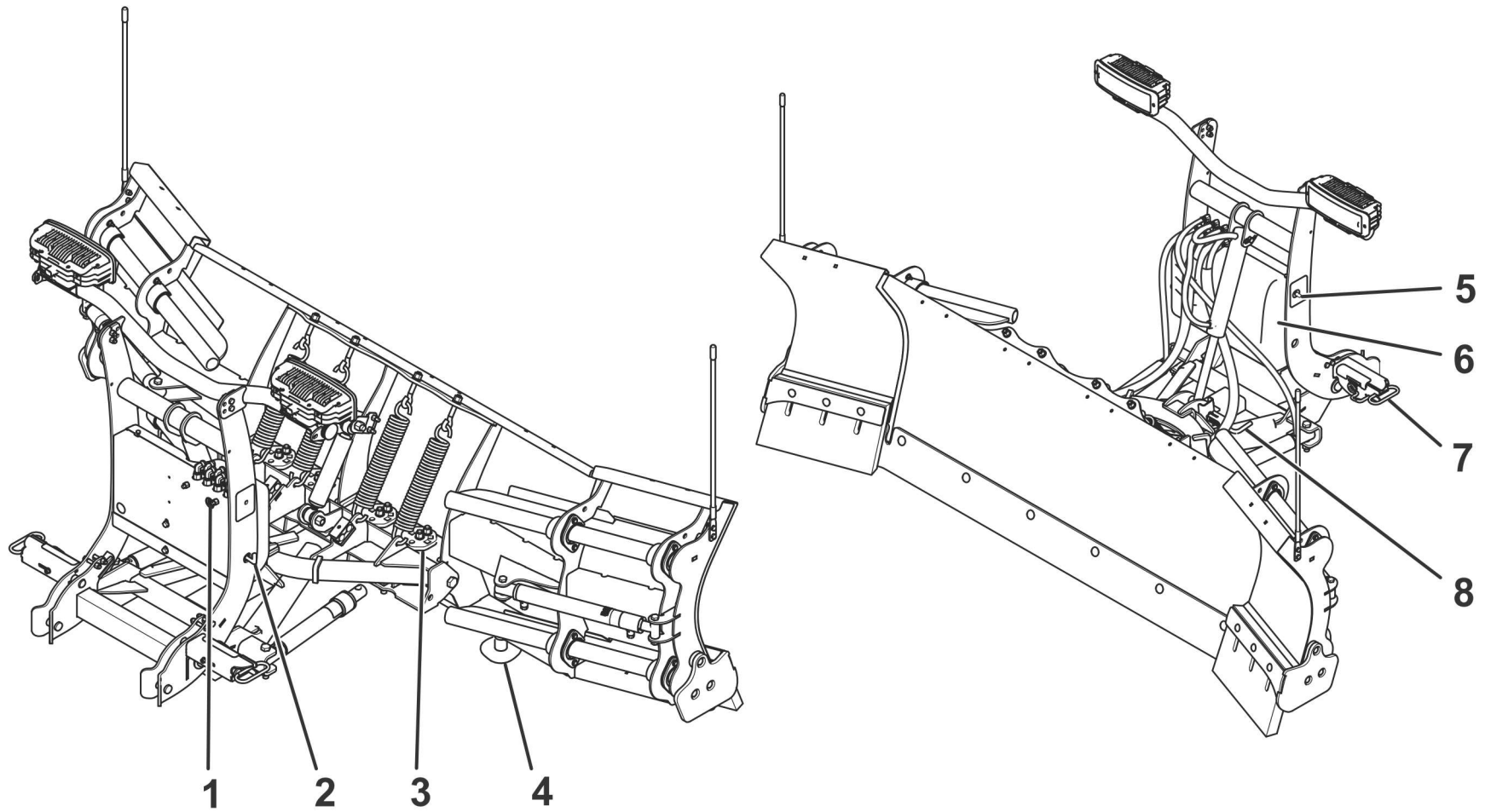

Figure 13
EXT Straight-Blade Plow

- 1. Hydraulic flow-control valve
- 2. Hydraulic reservoir fill elbow
- 3. Cam

- 4. Plow shoe
- 5. SmartHitch2 switch
- 6. Coupler-tower cover

- 7. Spring pin
- 8. Kickstand

g288290

Straight-Blade Controls

Joystick Controller

The joystick controller operates the movement of the snowplow.

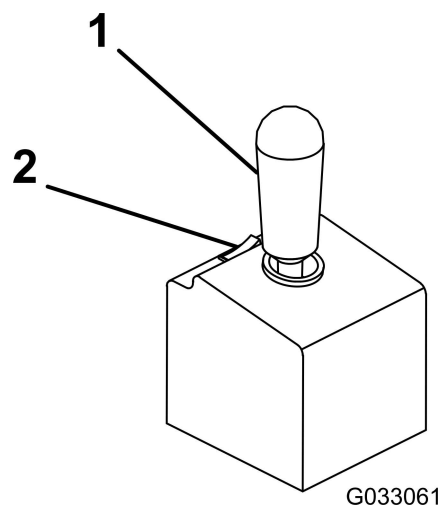

Figure 14

1. Joystick

2. On/Off switch

- On/Off switch—turns the plow controller on and off. A red light will illuminate when the controller is on.

Note: Turn off the controller when not in use to prevent accidental activation of the plow.

- Directional joystick—controls the direction that the plow moves
 - To raise the plow blade, pull the joystick back.
 - To lower the plow blade, push the joystick forward.
 - To angle the plow blade right, push the joystick right.
 - To angle the plow blade left, push the joystick left.
 - To activate the Float feature, push the joystick forward until it clicks into the detent position, allowing the plow blade to follow the contour of the ground. The joystick stays in the Float position until it is centered again.

SmartTouch2 Controller

The SmartTouch2 controller operates the movement of the snowplow.

Note: Plows equipped with D-Force must have a SmartTouch2 controller with a red center button.

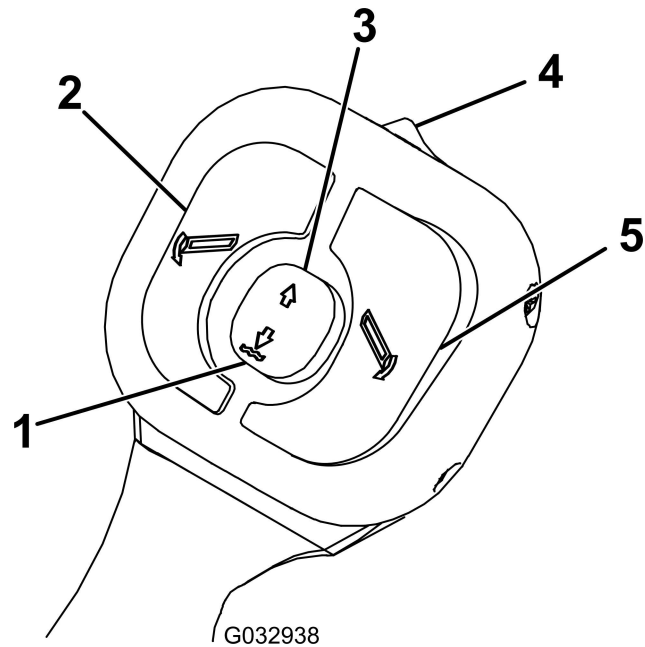

Figure 15

- | | |
|-----------------|------------------|
| 1. Lower button | 4. On/Off switch |
| 2. Left button | 5. Right button |
| 3. Raise button | |

- On/Off switch—turns the plow controller on and off. A green light illuminates when the controller is on.

Note: Turn off the controller when not in use to prevent accidental activation of the plow.

- Raise button—raises the plow blade. Pressing the button quickly twice automatically raises the blade when Express Raise mode is enabled; refer to [Setting Express Raise Mode \(page 54\)](#).
- Lower button—lowers the plow blade and activates the FLOAT and D-FORCE features.
 - FLOAT—double tapping the button or holding it for 2 seconds automatically lowers the blade and activates the FLOAT feature, allowing the plow blade to follow the contour of the ground. A red light illuminates when the FLOAT feature is active.
 - D-FORCE (optional)—if your plow is equipped with the D-FORCE feature, double tapping the button a second time activates it, applying a downward force on the blade to improve back blading. An orange light illuminates when the D-FORCE feature is active.

Note: You can only activate the D-FORCE feature twice before the plow must be raised.

Important: Only use the D-Force feature while back dragging to prevent damage to the plow or vehicle.

- Left button—angles the plow blade to the left
- Right button—angles the plow blade to the right
- Sleep mode—If you do not use the controller for 20 minutes, it enters sleep mode and the controller lights flash green and red. Turn the controller off to deactivate the sleep mode.

SmartHitch2 Switch

The SmartHitch2 switch controls the movement of the coupler tower to facilitate plow attachment and removal. With the controller in the Float mode, press the switch up to raise the tower and down to lower the tower.

Spring Pins

The spring pins secure the plow to the vehicle pushbeam. Turn the levers toward the coupler tower to lock the spring pins. Turn the levers away from the coupler tower to unlock the spring pins.

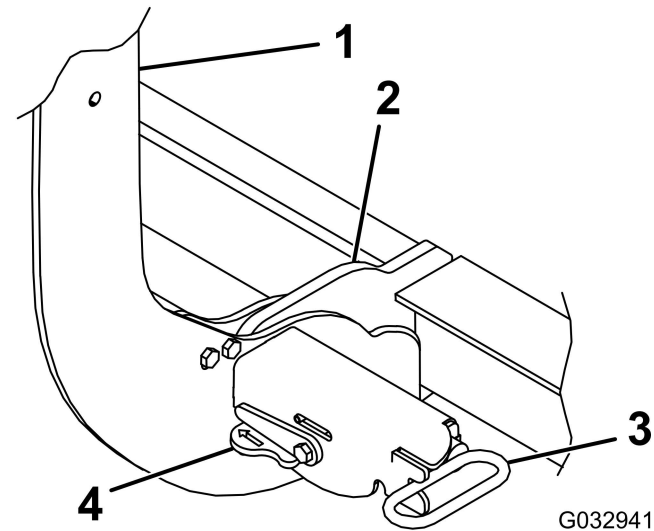

Figure 16

- | | |
|------------------|---------------|
| 1. Coupler tower | 3. Spring pin |
| 2. Pin receiver | 4. Lever |

Headlight Toggle Switch

The headlight toggle switch controls which set of headlights is being used. Move the switch to the TRUCK position to use the headlights on the vehicle. Move the switch to the PLOW position to use the headlights on the plow.

Kickstand

Pull the kickstand spring pin to raise and lower the kickstand.

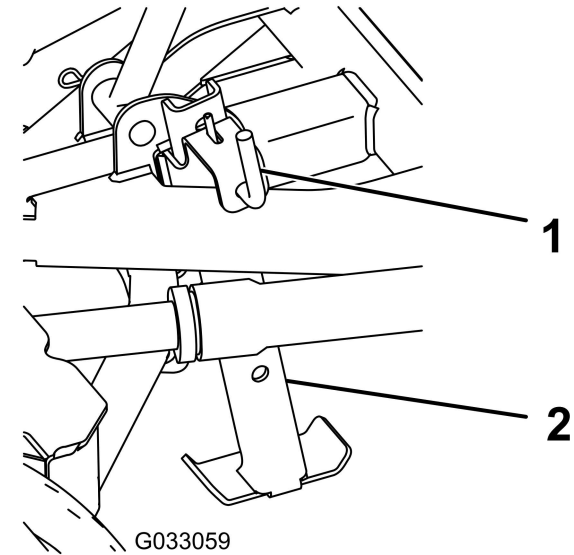

g033059

Figure 17

1. Kickstand spring pin 2. Kickstand

Plow Shoes

Plow shoes control how much contact the cutting edge of the plow has with the surface being plowed. When plowing solid, level areas, such as parking lots, roads, or driveways, plow shoes should be raised to increase contact. When plowing loose or uneven surfaces, such as dirt, gravel, or grass, plow shoes should be lowered

to decrease contact and prevent the surface from being dug up.

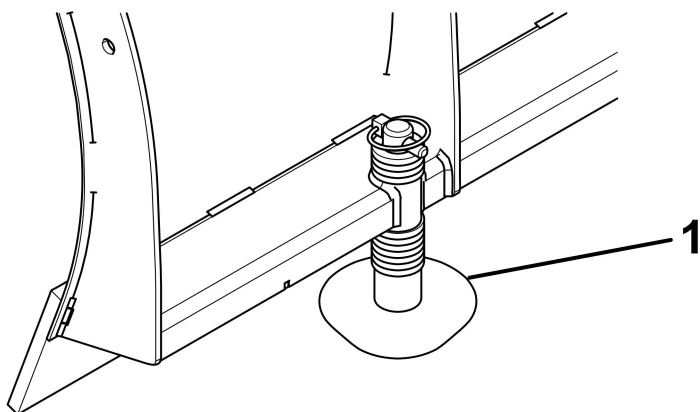

Figure 18

g230717

1. Plow shoe

EXT Straight-Blade Controls

SmartTouch2 Controller

The SmartTouch2 controller operates the movement of the snowplow.

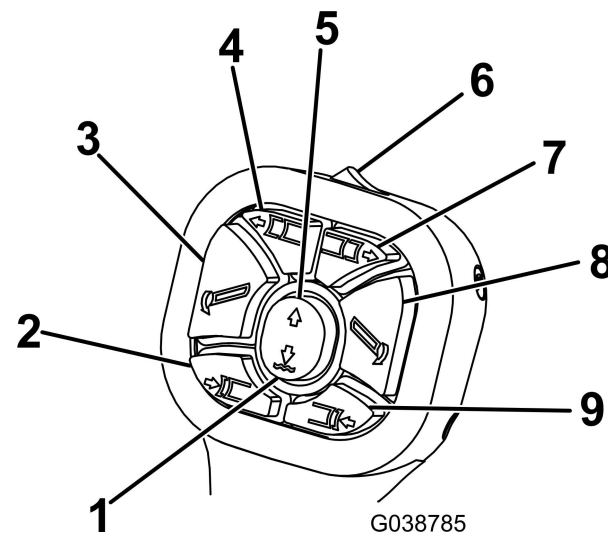

Figure 19

G038785

g038785

1. Lower/Float button
2. Left wing retract button
3. Left button
4. Left wing extend button
5. Raise button
6. On/Off switch
7. Right wing extend button
8. Right button
9. Right wing retract button

-
- On/Off switch—turns the plow controller on and off. A green light illuminates when the controller is on.

Note: Turn off the controller when not in use to prevent accidental activation of the plow.

- Raise button—raises the plow blade. Pressing the button quickly twice automatically raises the blade.
- Lower/Float button—lowers the plow blade and activates the FLOAT feature. Pressing the button quickly twice or holding it for 2 seconds automatically lowers the blade and activates the FLOAT feature, allowing the plow blade to follow the contour of the ground. A red light illuminates when the FLOAT feature is active.
- Left button—angles the plow blade to the left
- Right button—angles the plow blade to the right
- Left wing extend button—extends the left plow wing
- Right wing extend button—extends the right plow wing
- Left wing retract button—retracts the left plow wing

- Right wing retract button—retracts the right plow wing
- Sleep mode—If you do not use the controller for 20 minutes, it enters sleep mode and the controller lights flash green and red. Turn off the controller to deactivate the sleep mode.

SmartHitch2 Switch

The SmartHitch2 switch controls the movement of the coupler tower to facilitate plow attachment and removal. With the controller in the Float mode, press the switch up to raise the tower and down to lower the tower.

Spring Pins

The spring pins secure the plow to the vehicle pushbeam. Turn the levers toward the coupler tower to lock the spring pins. Turn the levers away from the coupler tower to unlock the spring pins.

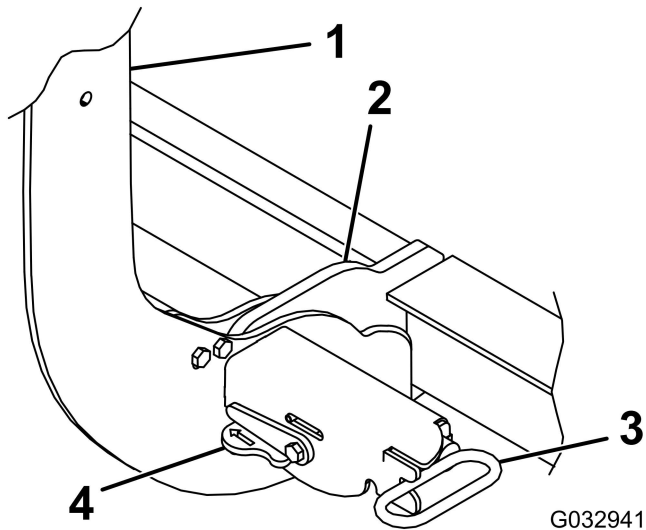

Figure 20

- | | |
|------------------|---------------|
| 1. Coupler tower | 3. Spring pin |
| 2. Pin receiver | 4. Lever |

Headlight Toggle Switch

The headlight toggle switch controls which set of headlights is being used. Move the switch to the TRUCK position to use the headlights on the vehicle. Move the switch to the PLOW position to use the headlights on the plow.

Kickstand

Pull the kickstand spring pin to raise and lower the kickstand.

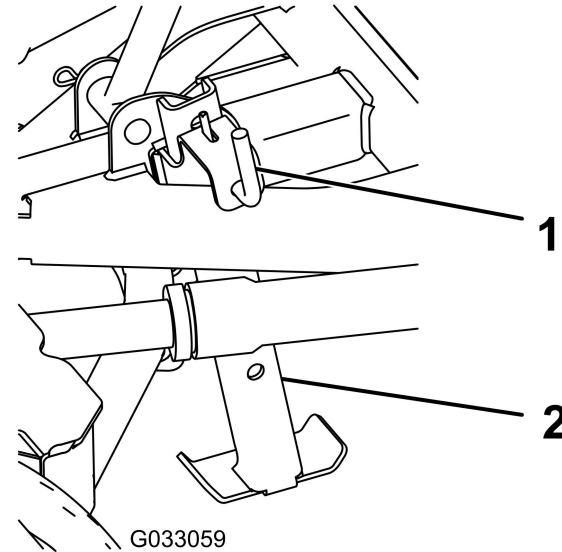

Figure 21

- | | |
|-------------------------|--------------|
| 1. Kickstand spring pin | 2. Kickstand |
|-------------------------|--------------|

Plow Shoes

Plow shoes control how much contact the cutting edge of the plow has with the surface being plowed. When plowing solid, level areas, such

as parking lots, roads, or driveways, plow shoes should be raised to increase contact. When plowing loose or uneven surfaces, such as dirt, gravel, or grass, plow shoes should be lowered to decrease contact and prevent the surface from being dug up.

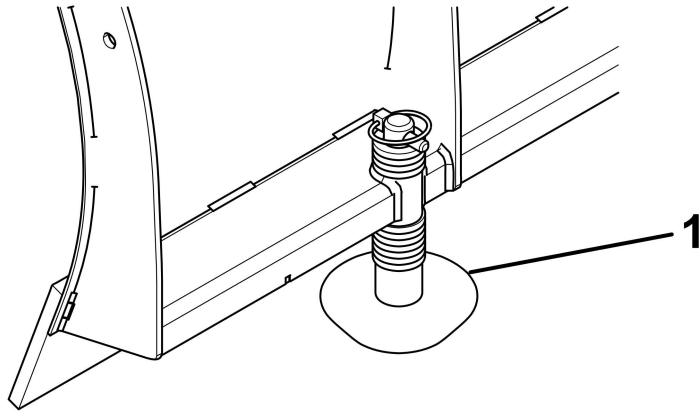

g230717

Figure 22

1. Plow shoe
-

Specifications

Note: Additional specifications are located at www.BOSSPlow.com.

Specifications and design are subject to change without notice.

Plow Type	Recommended push beam height
HTX straight-blade	36.8 cm (14-1/2 inches)
HTX V-blade	
Standard-duty straight-blade	39.3 cm (15-1/2 inches)
Super-duty straight-blade	
Trip-Edge straight-blade	
EXT straight-blade	
XT V-blade	
DXT V-blade (excluding the 10 ft DXT)	
10 ft DXT V-blade	41.9 cm (16-1/2 inches)
Heavy-duty straight-blade	

Attachments/Accessories

A selection of BOSS approved attachments and accessories is available for use with the machine to enhance and expand its capabilities. Contact your Authorized Service Dealer or authorized BOSS distributor or go to www.BOSSPlow.com for a list of all approved attachments and accessories.

To ensure optimum performance and continued safety certification of the machine, use only genuine BOSS replacement parts and accessories. Replacement parts and accessories made by other manufacturers could be dangerous, and such use could void the product warranty.

Operation

Determine the left and right sides of the machine from the normal operating position.

Before Operation

- Familiarize yourself with the *Owner's Manual* before operating or servicing your snowplow.
- Familiarize yourself with local snowplowing laws and regulations.
- Carry the following safety equipment and items in case of emergencies:
 - fire extinguisher
 - tool kit
 - tow strap
 - flashlight
 - flares
 - first-aid kit
 - fuses for your vehicle
 - jumper cables
 - lock deicer
 - ice scraper

- washer fluid
- shovel
- bag of salt or sand

Note: In case of emergencies, always carry a cell phone or 2-way radio when plowing.

- Wear warm clothes while plowing, including insulated boots, insulated underwear, a warm jacket, hat, gloves, and sunglasses.
- Carry the following snowplow equipment in case of emergencies:
 - hydraulic fluid
 - hydraulic hoses
 - pump solenoid
 - cutting-edge bolts
 - trip spring
 - BOSS Emergency Spare Parts kit

- Ensure that your vehicle has been maintained according to the manufacturer's recommendation.
- Consider adding a strobe light or backup lights to your vehicle if they are not already equipped.
- Ensure that your vehicle complies with the federal requirements for front and rear weight distribution. Any ballast should be placed behind the rear axle toward the tailgate and secured in place.
- Ensure that all snowplow bolts are tight and torqued properly.
- Ensure that the snowplow lights are properly aligned and functioning.
- Ensure that your snowplow blade is not over-worn and in need of replacing.
- Do not exceed 64 km/h (40 mph) when transporting plow.
- When transporting the plow, keep the plow in the straight or V position to reduce the chance of catching a curb or snowbank.
- Turn off the plow controller when transporting the plow to and from a job site.
- When transporting the plow, do not block the plow headlights or your vision with the raised plow.
- Check the temperature gauge often while transporting the plow or plowing. If the vehicle overheats while transporting the plow, stop and adjust the plow position to allow more airflow to the radiator.
- Before it snows, inspect the location you will be plowing and look for obstacles that will become hidden once it snows. Look for things such as bumper stops, speed bumps, curbs, shrubs, water drains, fire hydrants, fences, and pipes. To prevent damaging the area being plowed, your plow, or your vehicle, mark any obstructions in a way that will be visible after it snows.

Mounting the Snowplow

Mounting V-Blade Snowplows

Note: The vehicle must be running before starting this procedure.

1. Turn the vehicle key to Accessories or start the vehicle.
2. Activate the Float feature on your plow controller.
3. Line up the vehicle with the snowplow and slowly drive forward until the lower pin contacts the push-beam pin receiver ([Figure 23](#)).

Note: Ensure that the pushbeam is at the correct height for your plow. Refer to [Specifications \(page 28\)](#) for the recommended pushbeam height. Refer to [Adjusting the Pushbeam Height \(page 53\)](#) if the pushbeam is not at the correct height.

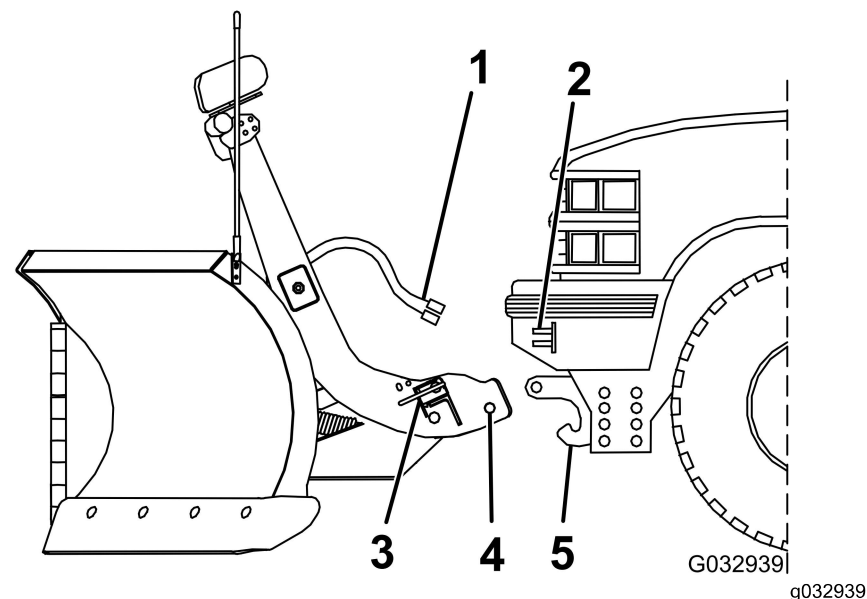

Figure 23

- | | |
|-------------------------|-----------------|
| 1. Plow wire harness | 4. Lower pin |
| 2. Vehicle wire harness | 5. Pin receiver |
| 3. Spring pin | |

-
4. Turn the levers on the spring pins to the LOCK position ([Figure 24](#)).

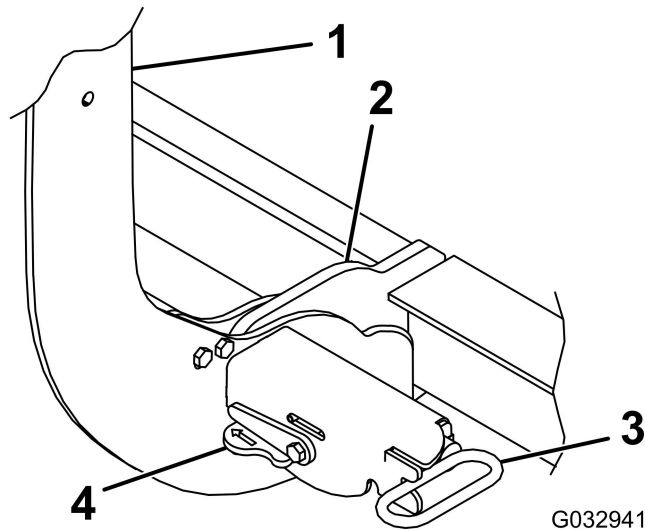

Figure 24

- | | |
|------------------|---------------|
| 1. Coupler tower | 3. Spring pin |
| 2. Pin receiver | 4. Lever |

g032941

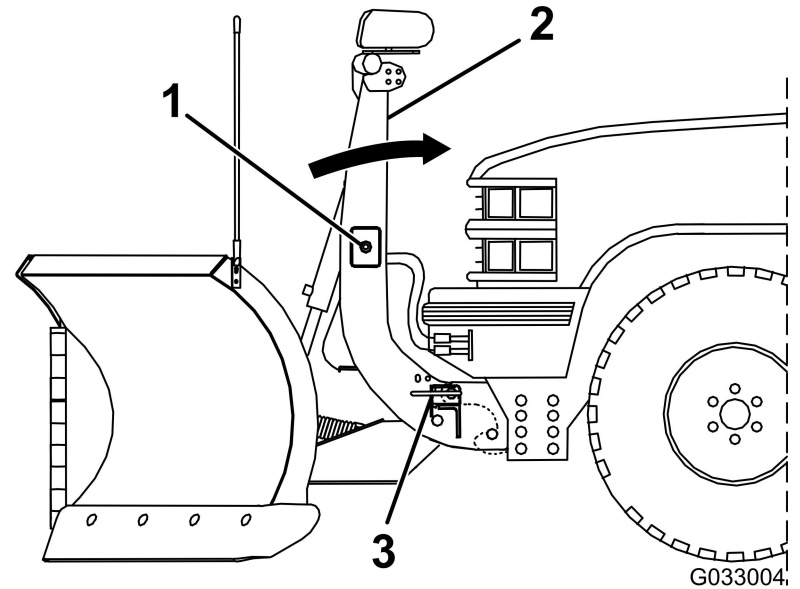

Figure 25

- | | |
|-----------------------|---------------|
| 1. SmartHitch2 switch | 3. Spring pin |
| 2. Coupler tower | |

g033004

-
5. Remove the electrical-plug dust covers and connect the plow wire harness to the vehicle wire harness ([Figure 23](#)).
 6. Push the SmartHitch2 switch on the side of the coupler tower upward and raise the tower until the spring pins lock in ([Figure 25](#)).

-
7. Ensure that both spring pins have fully engaged the coupler ([Figure 24](#)).
- Note:** Move the coupler tower until the spring pins engage completely.
8. Switch the headlight toggle switch to the PLOW position.

Mounting Straight-Blade Snowplows

Note: The vehicle must be running before starting this procedure.

1. Turn the vehicle key to Accessories or start the vehicle.
2. Activate the Float feature on your plow controller.
3. Line up the vehicle with the snowplow and drive forward until the lower pin contacts the push-beam pin receiver ([Figure 26](#)).

Note: Ensure that the pushbeam is at the correct height for your plow. Refer to [Specifications \(page 28\)](#) for the recommended pushbeam height. Refer to [Adjusting the Pushbeam Height \(page 53\)](#) if the pushbeam is not at the correct height.

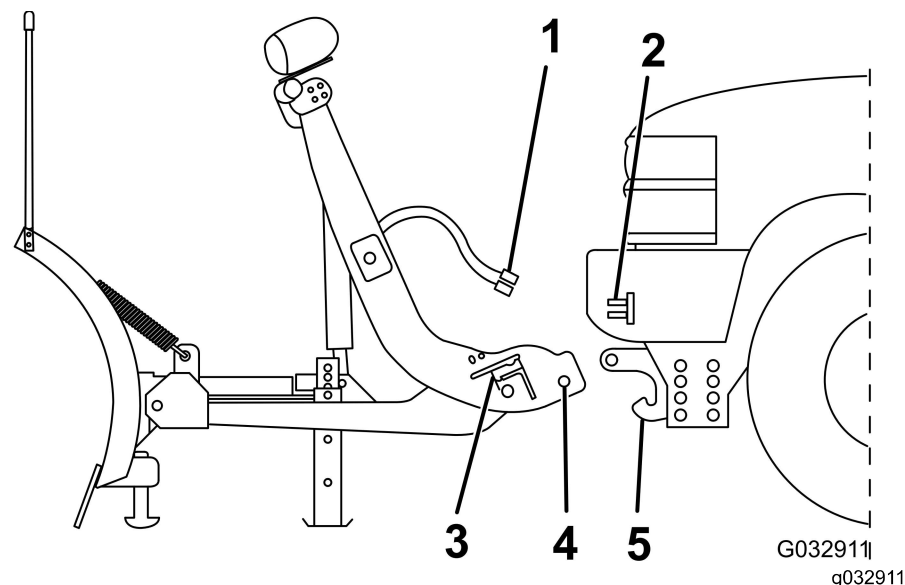

Figure 26

- | | |
|-------------------------|-----------------|
| 1. Plow wire harness | 4. Lower pin |
| 2. Vehicle wire harness | 5. Pin receiver |
| 3. Spring pin | |

-
4. Turn the levers on the spring pins to the LOCK position ([Figure 27](#)).

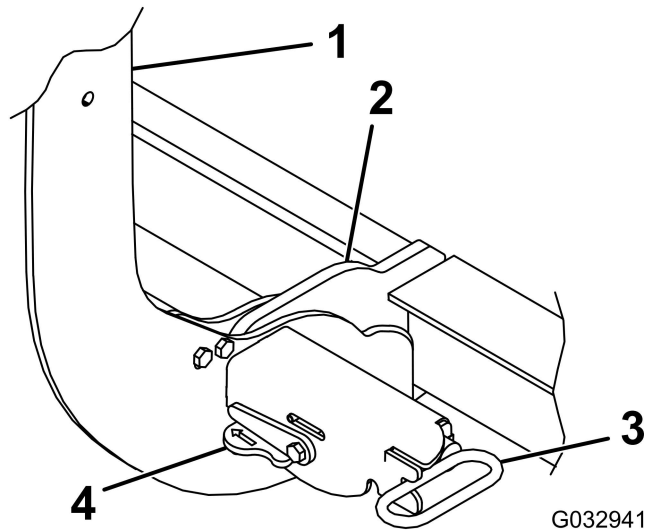

Figure 27

- | | |
|------------------|---------------|
| 1. Coupler tower | 3. Spring pin |
| 2. Pin receiver | 4. Lever |

-
- Remove the electrical-plug dust-covers and connect the plow wire harness to the vehicle wire harness ([Figure 26](#)).
 - Push the SmartHitch2 switch on the side of the coupler tower upward and raise the tower until the spring pins snap in ([Figure 28](#)).

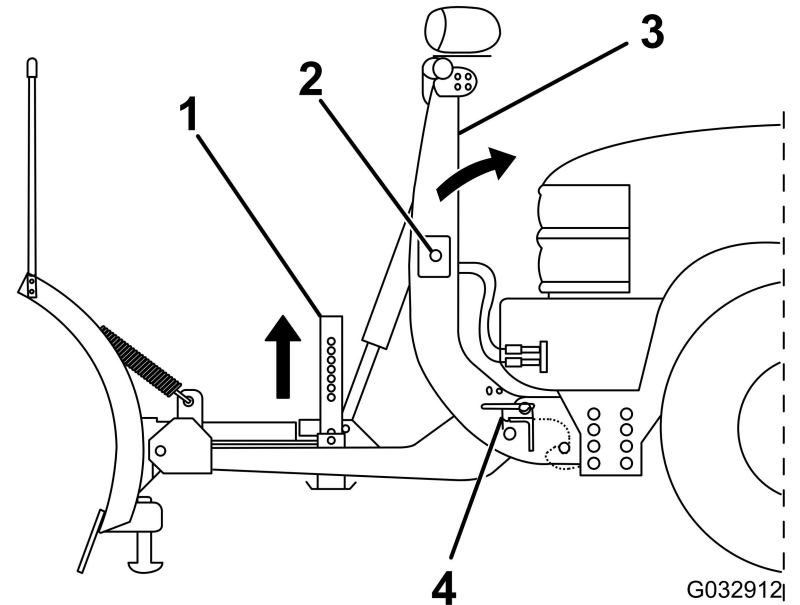

Figure 28

- | | |
|-----------------------|------------------|
| 1. Kickstand | 3. Coupler tower |
| 2. SmartHitch2 switch | 4. Spring pin |

-
- Ensure that both spring pins have fully engaged the coupler ([Figure 27](#)).

Note: Move the coupler tower until the spring pins engage completely.

8. Pull the kickstand spring pin outward and raise the kickstand, then release the spring pin to secure it ([Figure 28](#)).
9. Switch the headlight toggle-switch to the PLOW position.

Checking the Hydraulic Fluid Level

1. With the plow mounted to the vehicle, lower the plow to the ground and ensure that it is in the straight position.

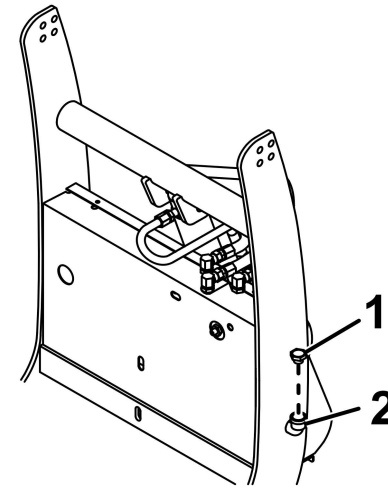

g230862

Figure 29

1. Fill cap
2. Fill elbow

-
2. Clean the area around the fill cap ([Figure 29](#)).
 3. Remove the fill cap from the hydraulic reservoir ([Figure 29](#)).
 4. Ensure that the fluid comes up to the bottom of the fill elbow. If it does not, add more hydraulic fluid; refer to [Adding Hydraulic Fluid \(page 37\)](#).
 5. Install the previously removed fill cap.

Adding Hydraulic Fluid

1. Ensure that the lift cylinder is completely collapsed.

Note: The lights should tilt forward.

Important: Do not manually pull the tower down. This can cause an air pocket to form in the hydraulic system and fluid to spill out of the internal filler cap.

2. Clean the area around the fill cap (Figure 29).
3. Remove the fill cap from the hydraulic reservoir (Figure 30).

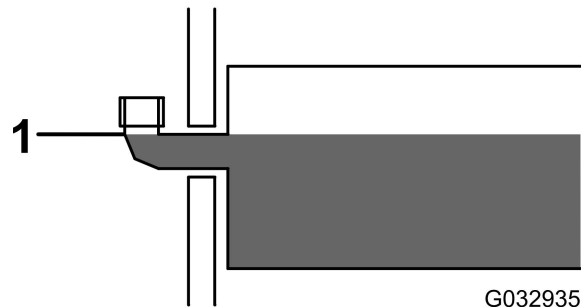

Figure 30

g032935

1. Fill elbow

4. Slowly fill the reservoir with BOSS high-performance hydraulic fluid to the bottom of the fill elbow (Figure 30).

Note: The reservoir holds approximately 1.9 L (2 US qt) of hydraulic fluid.

5. Install the previously removed fill cap.
6. Start the vehicle and operate the plow in its full range of movement.
7. Stop the vehicle, check the hydraulic-fluid level, and replenish the fluid if necessary; refer to [Checking the Hydraulic Fluid Level \(page 36\)](#).

During Operation

- Do not exceed 22 km/h (14 mph) when plowing.
- Always wear a seatbelt while plowing.
- Never plow with your head out the window.
- When moving in reverse, turn and look behind you instead of relying on vehicle mirrors.
- When plowing on dirt or gravel, lower the plow shoes to prevent scraping away the surface.
- When plowing on asphalt or concrete, raise the plow shoes to scrape as close to the surface as possible.
- Start driving forward before lowering the plow for a pass.
- As you come to the end of a pass, lift off the accelerator while starting to use the brake. At the same time, start to raise the blade to help stack the snow and to make it easier on your electrical system.

Protecting Your Transmission

Transmission damage is 1 of the most common problems that occur while plowing. The following steps can help prevent transmission damage:

- Do not plow in overdrive unless your vehicle's *Owner's Manual* recommends it.
- Plan your plow pattern so that you drive forward as much as possible.
- Come to a complete stop before shifting from forward to reverse.
- Wait until the transmission engages before accelerating.
- Accelerate slowly, allowing the tires to grip the road surface for better traction. Avoid spinning the tires.
- Start driving forward before lowering the plow for a pass.
- Whenever possible, back into a cleared area.

- If you have a manual transmission, avoid riding the clutch while plowing.
- Change the transmission fluid before and during the plowing season. If the fluid has a burnt smell, change the fluid as soon as possible.
- You can install an inline transmission heat gauge to monitor the temperature in your transmission. If it reaches 121°C (250°F), let the vehicle idle until the fluid cools.

Plowing Parking Lots

- Make sure you know where the customer wants you to pile the snow.
- Use caution when plowing next to curbs.
- If a significant amount of snow is expected, plow during the storm rather than letting snow accumulate.
- Keep water drains and catch basins clear at all times.
- Do not stack snow by the road and block the visibility of vehicles coming or leaving the parking lot.
- Use caution when plowing next to parked cars.
- When plowing snow that is next to a building, push snow away from the building.
- If you are responsible for clearing sidewalks, shovel them first so that you can plow the snow away.
- Plow areas in front of buildings and overhead doors first. With the blade raised and in the straight position, drive up to the building, drop the blade, and pull the snow away from the building. Turn your vehicle around, then back into the cleared area and push the snow to the outer edges of the lot.
- Push the snowbanks back far enough to accommodate future snowfalls.

- After back dragging snow away from a building, start plowing the lot. Begin by making a pass down the center of the lot, and then push snow in windrows to the outer edges. If there has been a significant amount of snowfall, push as much bulk off the lot as possible, then go over it again. In large lots, it may be best to break your plowing down into smaller areas.
- Do not pile snow in the middle of the lot. It will be difficult to remove later.
- Do not pile snow near handicapped parking areas.
- Plow in straight lines whenever possible, and push snow to the outer edges of the lot. Keep the wind direction in mind and pile snow downwind to minimize drifting.
- Plow snow during low-traffic hours, and always be cautious of cars and people in the lot.
- Once the majority of snow is removed from the lot, start the cleanup work. Begin by plowing next to curbs. Be sure to square off corners where possible, and don't leave trails of snow behind.

Plowing Driveways

- Make sure that you know where the customer wants you to pile the snow.
- Drive up to the garage, drop the blade, then back up, pulling the snow approximately 2 truck lengths back. Turn the vehicle around and back into the cleaned area. With the blade angled to the center of the driveway, push the snow to the end of the driveway. Finish by pushing the snow into the corners at the end of the driveway. Be careful not to leave snow on the road or sidewalks.

Operating Tips

- **Angle position**—the blade is angled either to the left or right of the vehicle. Use this position for windrowing or for widening the first pass.
- **Straight position**—the blade is positioned directly in front of the vehicle. Use this position when back dragging.
- **V position**—the blades are retracted toward the vehicle. Use this position for first passes, plowing through deep snow, or punching through snowdrifts and hard-packed banks or windrows left by city and country plows.
- **Scoop position**—the blades are extended forward to create an inverted V. Use this position when you must push the snow straight ahead and not to the side, or for cleanup work.
- **Windrowing**—the blade is angled to the left or right of the vehicle. Use this to clear large areas by making consecutive passes.
- **Back dragging**—with the blade in the straight position, raise the blade and drive toward the building. Lower the blade and back up, pulling the snow away from the building. Back drag only 2 truck lengths, then turn around and push the snow the rest of the way.
- **Deep snow**—when plowing deep snow, raise the plow several inches off the ground and plow off the top layer of snow. Make several passes, plowing only enough snow to prevent overloading your equipment.
- **Wet snow**—when plowing wet snow, plow until the job is complete. Wet snow left in windrows overnight can freeze and turn into tank traps.

After Operation

- Lower the blade to the ground and turn off the plow controller when you have finished plowing.
- After plowing, let the vehicle idle for at least 10 minutes to allow the transmission fluid time to cool.

Removing the Snowplow

Removing V-Blade Snowplows

Note: The vehicle must be running before starting this procedure.

1. Switch the headlight toggle switch to the TRUCK position.
2. Move both plow wings in to the V position.
3. Activate the Float feature on your plow controller.
4. Turn the levers on the spring pins to the UNLOCK position ([Figure 31](#)).

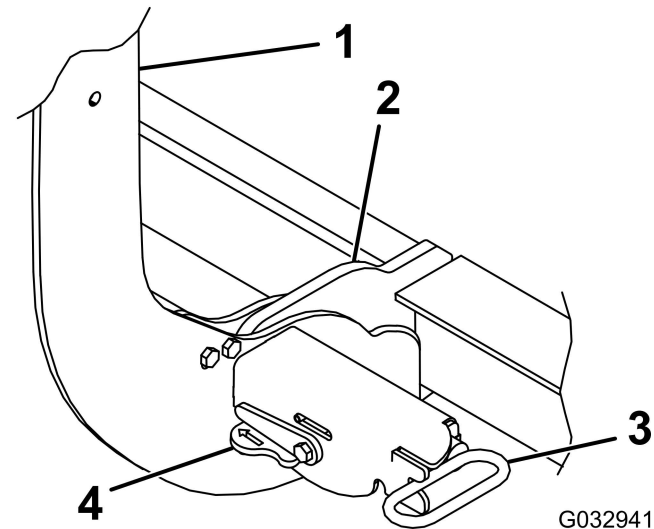

Figure 31

- | | |
|------------------|---------------|
| 1. Coupler tower | 3. Spring pin |
| 2. Pin receiver | 4. Lever |
-
5. Push the SmartHitch2 switch on the side of the coupler tower up to release the pins, then down to lower the tower completely ([Figure 32](#)).

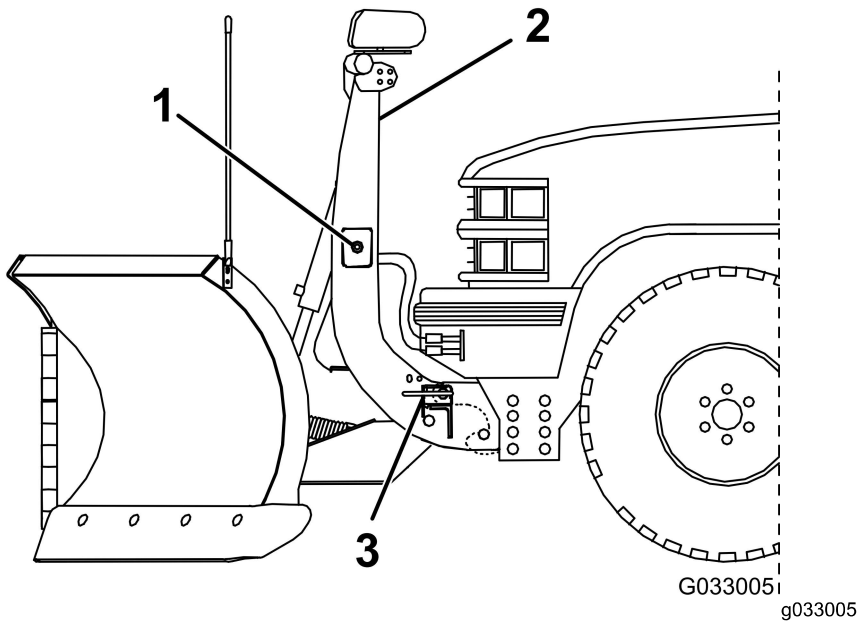

Figure 32

- 1. SmartHitch2 switch
- 2. Coupler tower
- 3. Spring pin

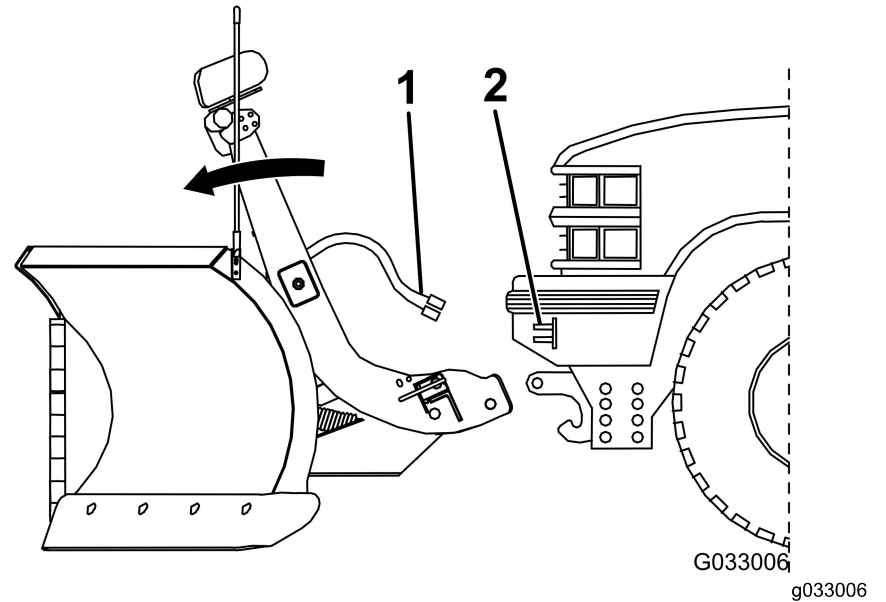

Figure 33

- 1. Plow wire harness
- 2. Vehicle wire harness

-
- 6. Disconnect the plow wire harnesses from the vehicle wire harnesses and secure the electrical-plug dust covers ([Figure 33](#)).

-
- 7. Slowly back the vehicle away from the snowplow.

Removing Straight-Blade Snowplows

Note: The vehicle must be running before starting this procedure.

1. Switch the headlight toggle switch to the TRUCK position.
2. Activate the Float feature on your plow controller.
3. Pull the kickstand spring pin outward and lower the kickstand, then release the spring pin to secure it ([Figure 34](#)).

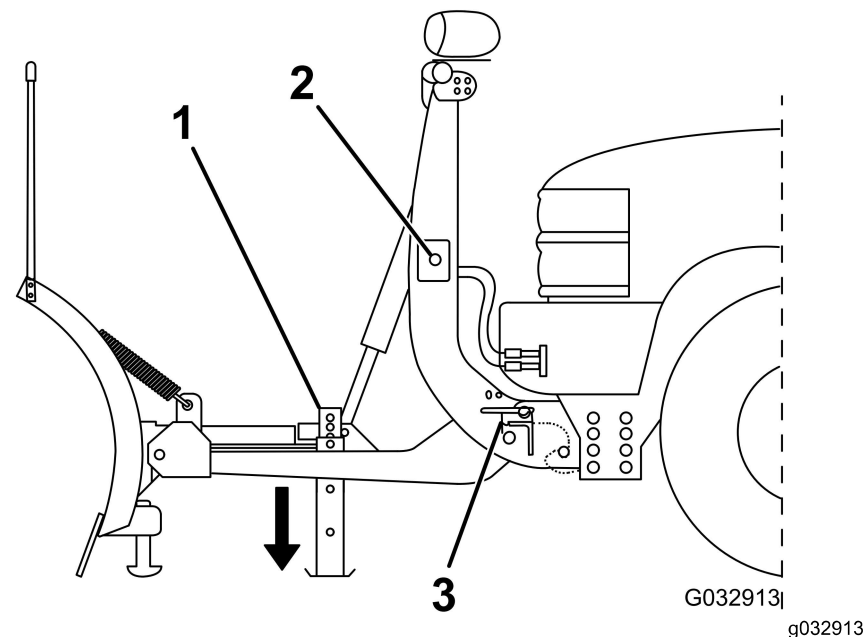

Figure 34

- | | |
|-----------------------|---------------|
| 1. Kickstand | 3. Spring pin |
| 2. SmartHitch2 switch | |

-
4. Turn the levers on the spring pins to the UNLOCK position ([Figure 35](#)).

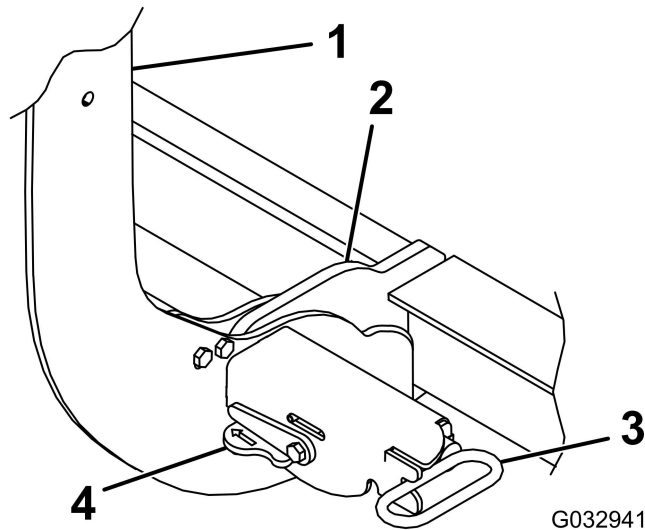

Figure 35

- | | |
|------------------|---------------|
| 1. Coupler tower | 3. Spring pin |
| 2. Pin receiver | 4. Lever |

-
5. Push the SmartHitch2 switch on the side of the coupler tower up to release the pins, then down to lower the tower completely (Figure 36).

g032941

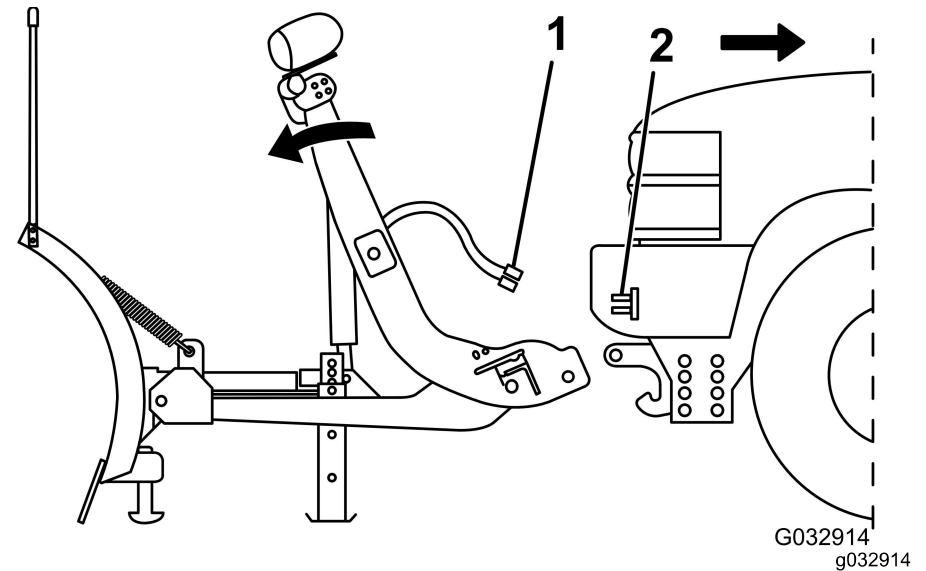

Figure 36

- | | |
|----------------------|-------------------------|
| 1. Plow wire harness | 2. Vehicle wire harness |
|----------------------|-------------------------|

-
6. Disconnect the plow wire harness from the vehicle wire harness and secure the electrical-plug dust covers (Figure 36).
 7. Slowly back the vehicle away from the snowplow.

Maintenance

Note: Determine the left and right sides of the machine from the normal operating position.

⚠ WARNING

Failure to properly maintain the machine could result in premature failure of machine systems, causing possible harm to you or bystanders.

Keep the machine well maintained and in good working order as indicated in these instructions.

⚠ CAUTION

If you leave the key in the switch, someone could accidentally start the engine and seriously injure you or other bystanders.

Remove the key from the switch before you perform any maintenance.

Recommended Maintenance Schedule(s)

Maintenance Service Interval	Maintenance Procedure
Before each use or daily	<ul style="list-style-type: none"> • Check the hydraulic cylinders. • Check the hydraulic-fluid level. • Check the hydraulic lines and hoses. • Check the torque of all fasteners, pins, retainers, nuts, and bolts. • Check the cutting edge. • Check the plow shoes. • Check the wire-harness connector. • Grease the coupler spring pins.
Before storage	<ul style="list-style-type: none"> • Grease the lift-cylinder rods. • Apply dielectric grease to the wire-harness connectors. • Grease the coupler spring pins. • Grease the vertical hinge bushings (V-blade plows only).
Monthly	<ul style="list-style-type: none"> • Apply dielectric grease to the wire-harness connectors.
Yearly	<ul style="list-style-type: none"> • Replace the hydraulic fluid.

Hydraulic System Maintenance

Draining the Hydraulic Fluid

If the oil becomes contaminated, follow the instructions below or contact your authorized BOSS dealer to have the system flushed.

1. Park the vehicle on a level surface, lower the plow, and fully collapse the hydraulic lift-cylinder. Turn off the vehicle and remove the keys.
2. Remove the hairpin cotter and clevis pin from the top of the lift cylinder and lean it forward (Figure 37).
3. Remove the 2 thumbscrews securing the coupler-tower cover to the coupler tower (Figure 37).
4. Remove the coupler-tower cover, pulling it toward the passenger side of the plow.

Note: You may need to tug the cover back and forth several times to get it free.

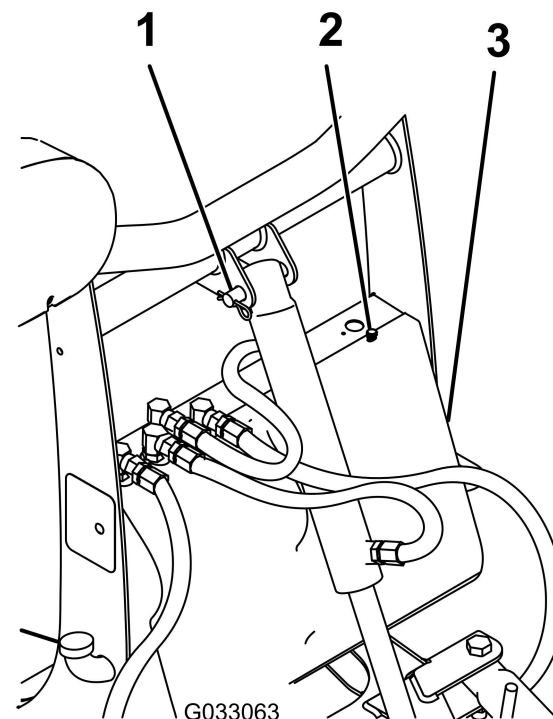

Figure 37

1. Hairpin cotter and clevis pin
 2. Thumbscrew
 3. Coupler-tower cover
-
5. Clean the area around the drain plug (Figure 38).

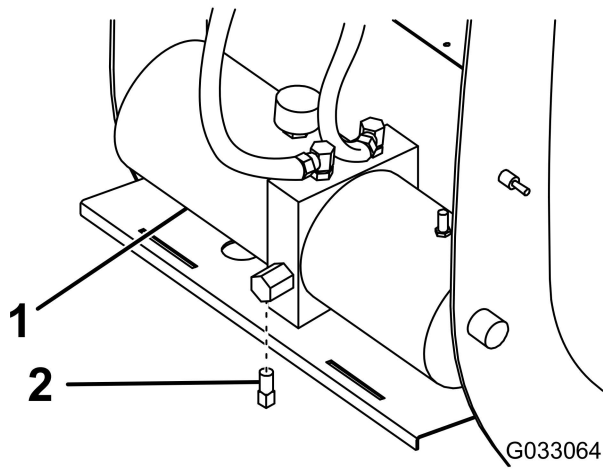

Figure 38

1. Hydraulic reservoir 2. Drain plug

Adding Hydraulic Fluid

1. Ensure that the lift cylinder is completely collapsed.

Note: The lights should tilt forward.

Important: Do not manually pull the tower down. This can cause an air pocket to form in the hydraulic system and fluid to spill out of the internal filler cap.

2. Clean the area around the fill cap ([Figure 39](#)).

-
6. Place a drain pan under the plug and remove the plug.
 7. Clean the drain plug.
 8. Allow the fluid to fully drain, then replace the plug. Torque the plug to 17 to 28 N·m (150 to 250 in-lb).
 9. Attach the previously removed coupler-tower cover.
 10. Attach the previously removed lift cylinder.

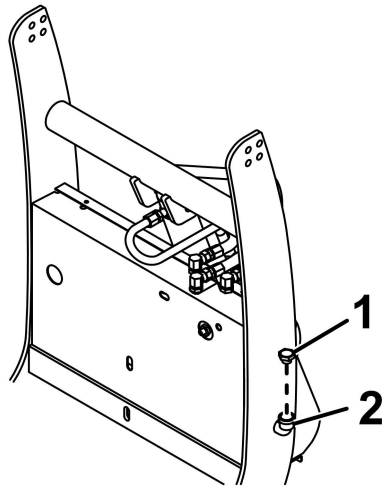

Figure 39

g230862

1. Fill cap
2. Fill elbow

-
3. Remove the fill cap from the hydraulic reservoir ([Figure 40](#)).

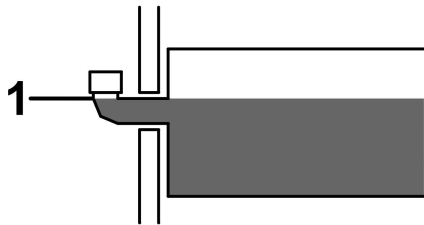

Figure 40

g231064

1. Fill elbow

4. Slowly fill the reservoir with BOSS high-performance hydraulic fluid to the bottom of the fill elbow ([Figure 40](#)).

Note: The reservoir holds approximately 1.9 L (2 US qt) of hydraulic fluid.

5. Install the previously removed fill cap.
6. Start the vehicle and operate the plow in its full range of movement.
7. Stop the vehicle, check the hydraulic-fluid level, and replenish the fluid if necessary; refer to [Checking the Hydraulic Fluid Level \(page 36\)](#).

Adjusting the Hydraulic Lowering Speed

⚠ WARNING

Adjusting the flow-control valve can cause the plow to drop suddenly, resulting in bodily harm.

- Ensure that all observers are standing a safe distance from the plow.
- Ensure that the controller is off before adjusting the plow.
- Keep your body away from the plow blade.

Note: There is no flow-control valve on the green hydraulic manifolds used for HTX snowplows.

1. Loosen the jam nut on the back of the hydraulic manifold ([Figure 41](#)).

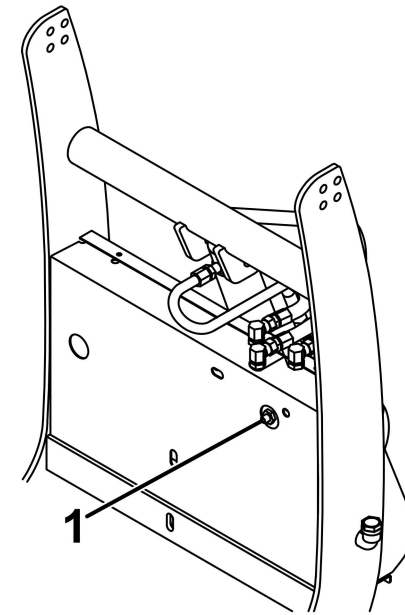

Figure 41

g230888

1. Jam nut

2. Adjust the set screw until you find the desired lowering speed.

Note: Turning the set screw clockwise decreases the lowering speed; turning the set screw counterclockwise increases the lowering speed.

3. Turn the jam nut until it is finger tight, then turn it 2 to 3 more times until snug.

Checking the Hydraulic Lines and Hoses

⚠ WARNING

Hydraulic fluid escaping under pressure can penetrate the skin and cause injury.

- **Ensure that all hydraulic-fluid hoses and lines are in good condition and all hydraulic connections and fittings are tight before applying pressure to the hydraulic system.**
- **Keep your body and hands away from pinhole leaks or nozzles that eject high-pressure hydraulic fluid.**
- **Use cardboard or paper to find hydraulic leaks.**
- **Safely relieve all pressure in the hydraulic system before performing any work on the hydraulic system.**
- **Get immediate medical help if fluid is injected into skin.**

Check the hydraulic lines and hoses daily for leaks, kinked lines, loose mounting supports, wear, loose fittings, weather deterioration, and chemical deterioration. Make all necessary repairs before operating.

Miscellaneous Maintenance

Adjusting the Pushbeam Height

1. Measure the distance from the ground to the coupler spring-pin holes on the undercarriage pushbeam (Figure 42). The measurement should match the height listed for your plow in Specifications (page 28).
2. If the pushbeam is not at the correct height, remove the fasteners securing the pushbeam to the undercarriage (Figure 42).
3. Move the pushbeam up or down and secure it with the previously removed hardware.
4. Torque the fasteners to 76 N·m (56 ft-lb).

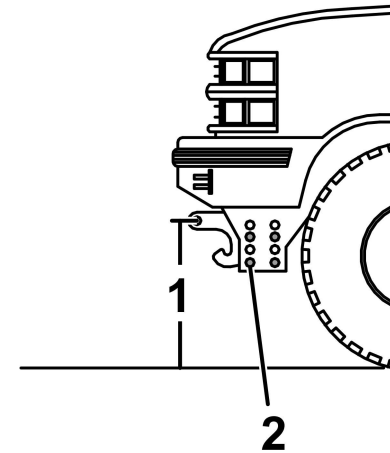

Figure 42

g230889

1. Measure this distance.
 2. Fastener
-

Setting Express Raise Mode

Non-EXT Snowplows Only

When Express Raise mode is enabled, pressing the Raise button on the controller quickly twice automatically raises the blade. To turn Express Raise mode on or off, perform the following steps.

1. With the controller turned off, press and hold the Raise button.
2. While still pressing the Raise button, turn the controller on. The controller will alternate flashing red and green.
3. Release the Raise button during the appropriate colored flash for the desired setting:
 - Release the button during the green flash to enable Express Raise mode.
 - Release the button during the red flash to disable Express Raise mode.

Note: The controller saves your setting until you change it using the above procedure.

Setting Heavy-Duty Mode

Non-EXT Snowplows Only

When Heavy-Duty mode is enabled, additional time is added to all plow functions. To turn Heavy-Duty mode on or off, perform the following steps.

1. With the controller turned off, press and hold the Lower button.
2. While still pressing the Lower button, turn the controller on. The controller will alternate flashing red and green.
3. Release the Lower button during the appropriate colored flash for the desired setting:
 - Release the button during the green flash to disable Heavy-Duty mode.
 - Release the button during the red flash to enable Heavy-Duty mode.

Note: The controller saves your setting until you change it using the above procedure.

Leveling the Plow Blades

V-Blade Snowplows Only

For XT and DXT V-Blade Snowplows

1. Loosen and carefully remove the 4 lock nuts and 4 washers from the trip-spring eye bolts (Figure 43).

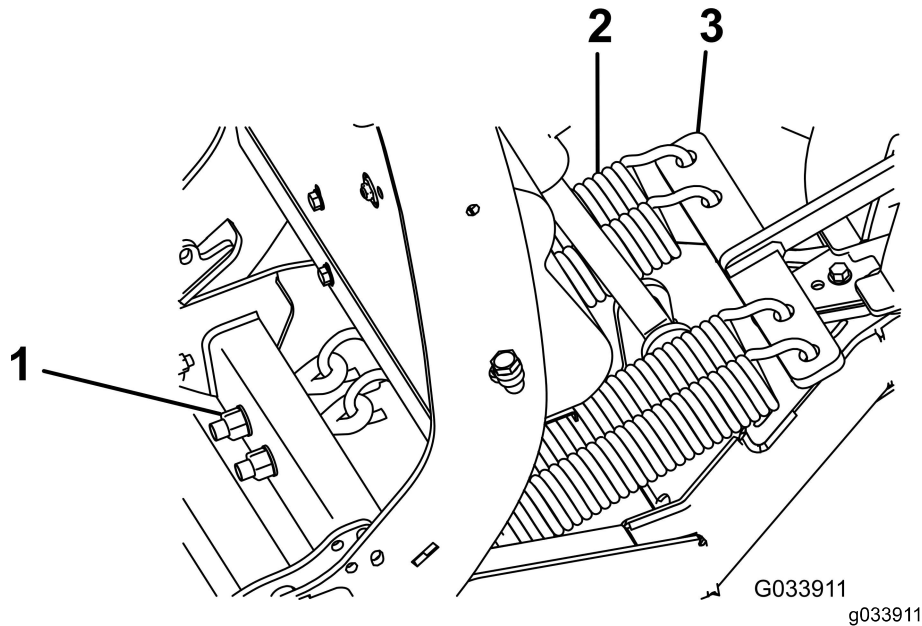

Figure 43

- | | |
|-----------------------|----------------|
| 1. Locknut and washer | 3. Spring yoke |
| 2. Trip spring | |

2. Adjust the bumper-stop plate (Figure 44).

Note: Slide the plate in to lower the center of the plow; slide the plate out to raise the center of the plow.

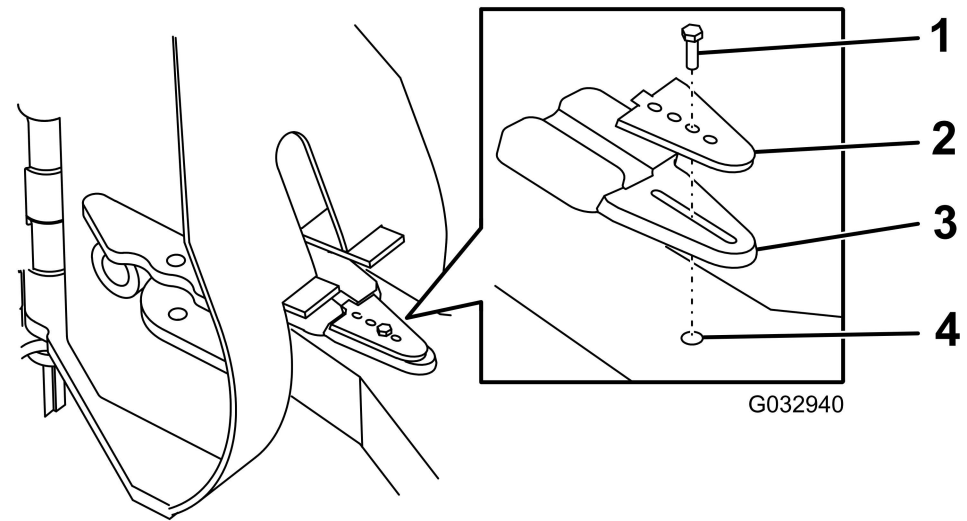

Figure 44

- | | |
|----------------------|----------------|
| 1. Bolt | 3. Bumper stop |
| 2. Bumper-stop plate | 4. Push frame |

3. Secure the plate to the bumper stop and push frame using the previously removed bolt (Figure 44). Torque the bolt to 31 N·m (23 ft-lb).

For HTX V-Blade Snowplows

1. Park the vehicle on a level surface and lower the plow in the V-position. If the plow is not flush against the ground, proceed to step 2. If the plow is flush against the ground, proceed to step 10.
2. Loosen and carefully remove the fasteners from the trip-spring eye bolts (Figure 45).

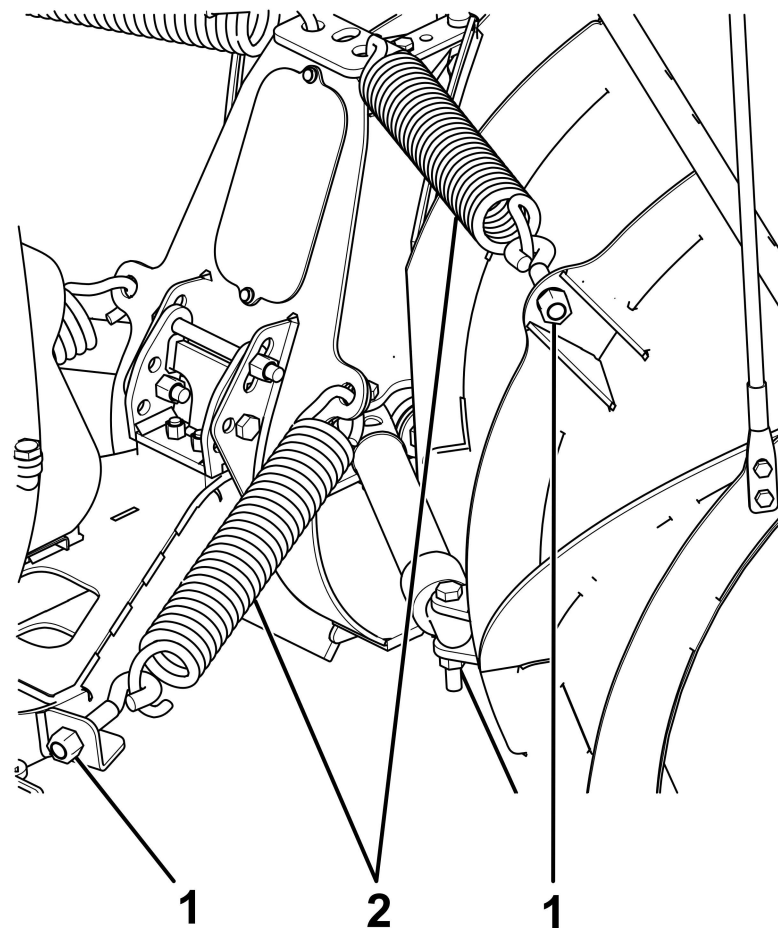

g270743

Figure 45

1. Fasteners

2. Trip spring

3. Loosen the fasteners securing the top of the bumper stop to the blade center section ([Figure 46](#)).

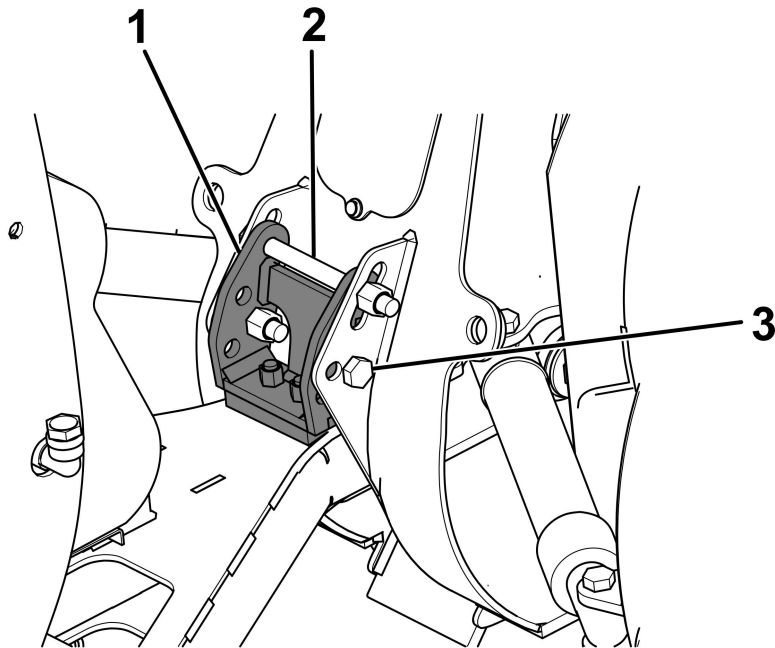

g270775

Figure 46

1. Bumper stop
2. Top fastener
3. Side fastener

-
4. Remove the 2 fasteners securing the sides of the bumper stop to the blade center section ([Figure 46](#)).

5. Slide the bumper stop to the desired position and secure it to the blade center section using the previously removed side fasteners.

Note: Slide the bumper stop down to lower the center of the plow; slide the bumper stop up to raise the center of the plow.

6. Tighten the fasteners securing the top of the bumper stop.
7. Torque the fasteners to 76 N·m (56 ft-lb).
8. Secure the trip-spring eye bolts with the previously removed fasteners ([Figure 45](#)).
9. Tighten the fasteners until there is a gap of 0.8 mm (1/32 inch) between the trip spring coils.
10. Raise the plow, then lower the blade in the scoop position. If the plow is not flush against the ground, repeat steps [2](#) through [9](#).

Adjusting the Angle of Attack

EXT Straight-Blade Snowplows Only

1. Park the vehicle on a level surface and lower the plow completely. If the plow is not flush against the ground, adjust the angle of attack.
2. Loosen the trip springs.
3. On the cams, remove the bolt in the square hole and loosen the bolt in the center (Figure 47).
4. Rotate the cam clockwise to angle the bottom of the blade back. Rotate the cam counterclockwise to angle the bottom of the blade forward.

Note: Use a 1/2 inch ratchet to help rotate the cams.

5. Insert the previously removed bolt, and torque it to 76 N·m (56 ft-lb).

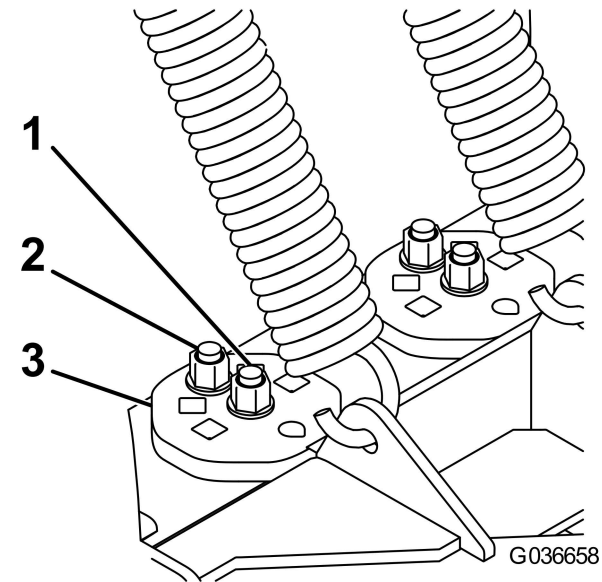

Figure 47

g036658

- | | |
|-------------------------|--------|
| 1. Center bolt (loosen) | 3. Cam |
| 2. Square bolt (remove) | |
-
6. Tighten the center bolt, and torque it to 76 N·m (56 ft-lb).
 7. Tighten the trip springs until there is a gap of 0.8 mm (1/32 inch) between the trip spring coils.

Replacing the Torsion Springs

DXT Snowplows Only

Removing the Torsion Springs

1. Park the vehicle on a level surface, lower the plow so that the pushframe is supported on jack stands, and fully collapse the hydraulic lift-cylinder. Turn off the vehicle and remove the key.
2. Remove the nuts securing the tension pins ([Figure 48](#)).
3. Place the end of a strong pipe on the upper spring leg and relieve the tension enough to remove the tension pin ([Figure 48](#)). Gently return the spring to a resting position.

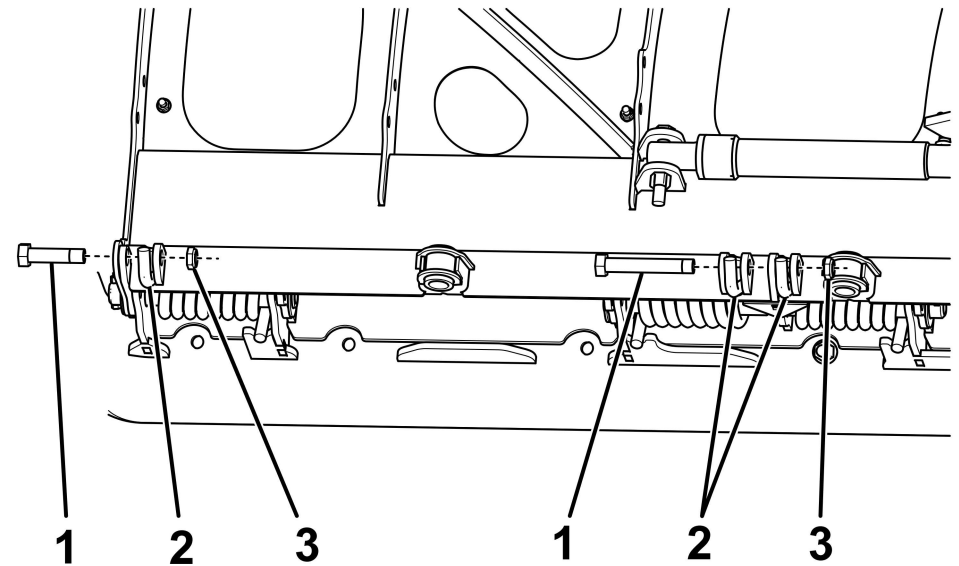

g275239

Figure 48

- | | |
|---------------------|--------|
| 1. Tension pin | 3. Nut |
| 2. Upper spring leg | |

4. Remove the fasteners securing the spring pins (Figure 49).

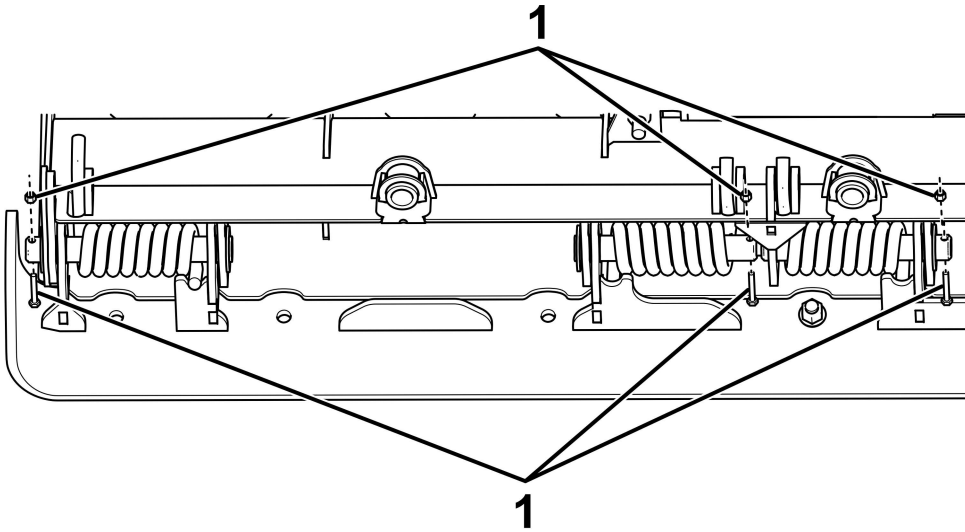

Figure 49

g275240

1. Remove
-

5. Remove the spring pins and torsion springs (Figure 50).

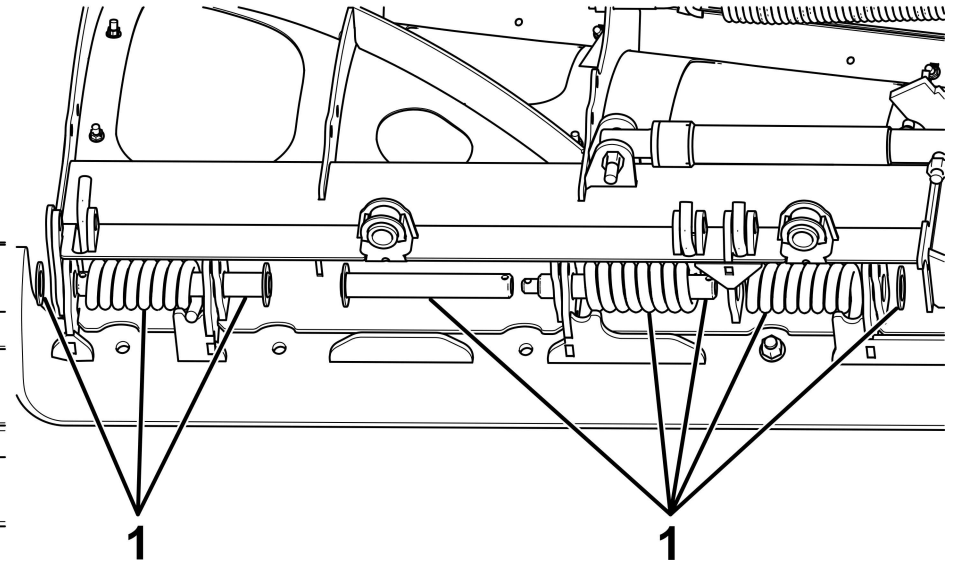

Figure 50

g275241

1. Remove
-

Installing the Torsion Springs

1. Position the torsion springs so that the long, angled leg is inserted through the hole in the bottom channel ([Figure 51](#)).

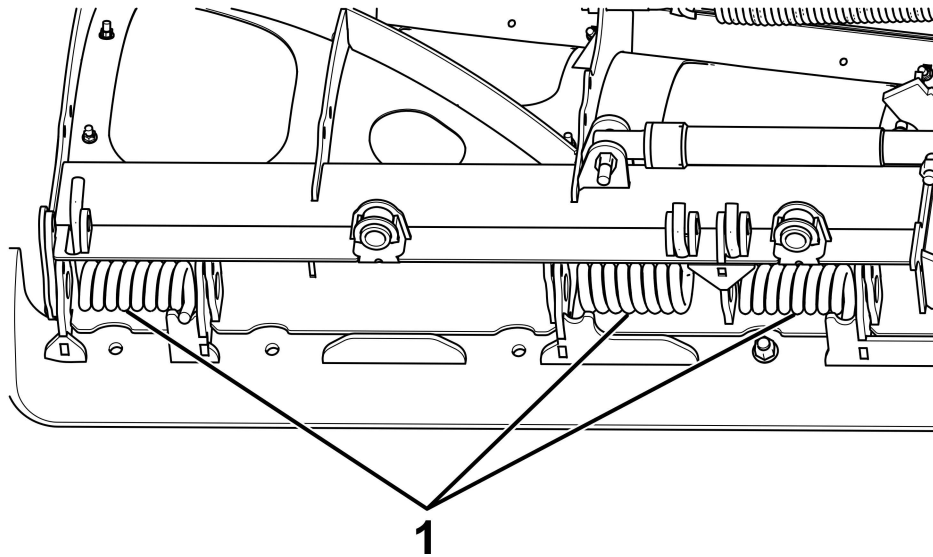

Figure 51

1. Torsion spring
-
2. Secure the outer spring with the single spring pin, washer (1-1/4 inches), bolt (1/4 x 20 inches), and nut (1/4 inch) as shown in [Figure 52](#).

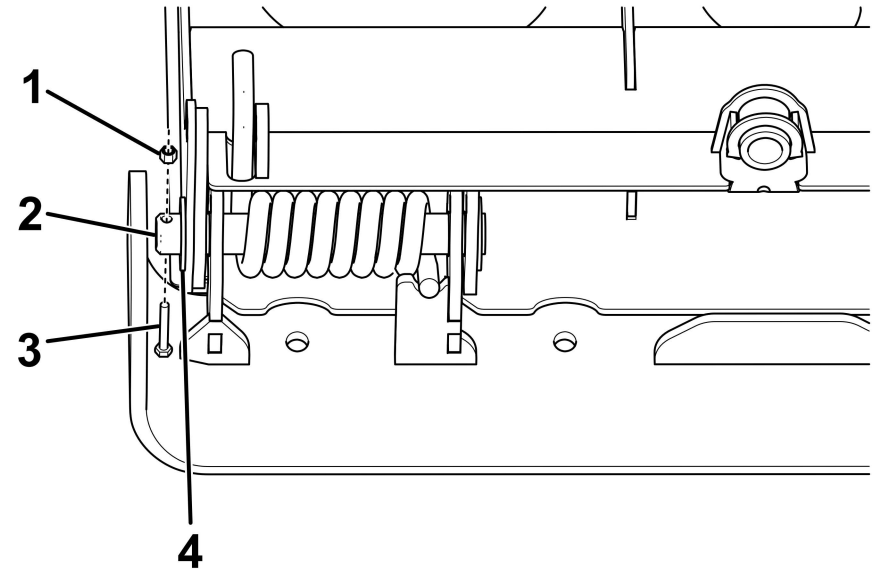

Figure 52

- | | |
|----------------------|---------------------------|
| 1. Nut (1/4 inch) | 3. Bolt (1/4 x 20 inches) |
| 2. Single spring pin | 4. Washer (1-1/4 inches) |

3. Slide the male and female spring pins through the 2 inner springs and secure them using a washer (1-1/4 inches), 2 bolts (1/4 x 20 inches), and nut (1/4 inch) as shown in [Figure 53](#).

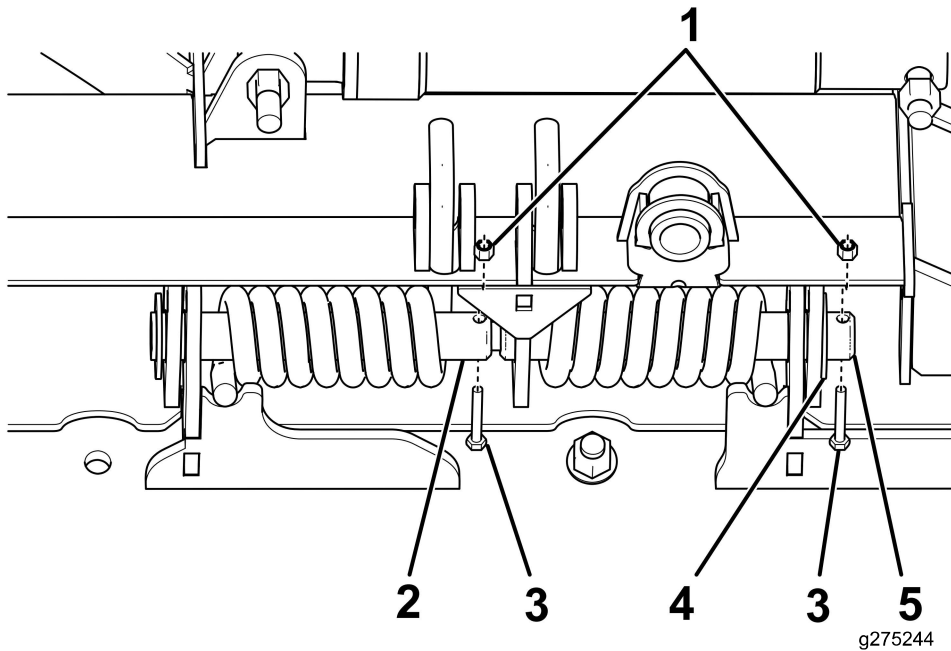

Figure 53

- | | |
|---------------------------|--------------------------|
| 1. Nut (1/4 inch) | 4. Washer (1-1/4 inches) |
| 2. Female spring pin | 5. Male spring pin |
| 3. Bolt (1/4 x 20 inches) | |

-
- Place the end of a strong pipe on the upper spring leg and move it enough to fully insert the tension pins, sliding the bushings between the tension pin brackets ([Figure 54](#)). Gently return the spring to a resting position.

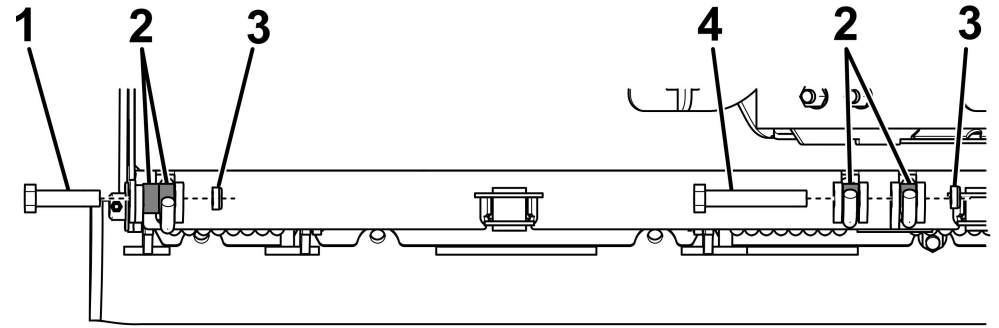

Figure 54

- | | |
|----------------------|---------------------|
| 1. Short tension pin | 3. Nut (3/4 inch) |
| 2. Bushing | 4. Long tension pin |

-
- Secure the tension pins with a nut (3/4 inch).

Replacing the Trip Bar DXT Snowplows Only

- Park the vehicle on a level surface, lower the plow so the pushframe is supported on jack stands, and fully collapse the hydraulic lift-cylinder. Turn off the vehicle and remove the key.
- Remove the cutting edge from the trip bar if you are not replacing it at this time.

3. Remove all of the torsion springs from the bottom of the plow and discard the trip bar; refer to [Removing the Torsion Springs \(page 59\)](#).
4. Line up the new trip bar with the pivot tabs on the bottom channel ([Figure 55](#)).

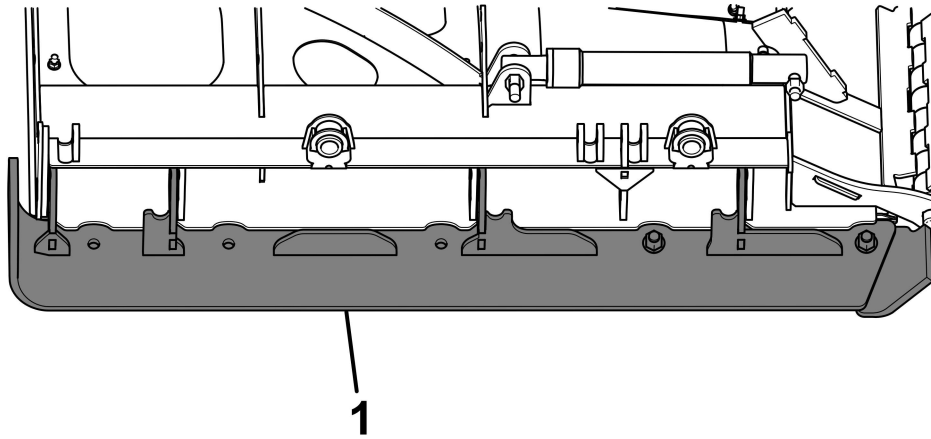

Figure 55

g275246

1. Trip bar

5. Install the torsion springs; refer to [Installing the Torsion Springs \(page 61\)](#).
6. Install the cutting edge to the trip bar using the previously removed fasteners. If you are installing a new cutting edge, refer to

the *Installation Instructions* for your cutting edge.

Adjusting the Aim of the Plow Headlights

Important: Certify that the installation of the snowplow lights conforms to applicable federal motor vehicle safety standards.

1. Park the vehicle on a level surface 7.5 m (25 ft) away from a matte white screen or garage door.

Note: The screen should be perpendicular to both the ground and the front of the vehicle.

2. Ensure that the vehicle is equipped for normal operation with the snowplow attached and in the raised position.
3. Perform the following actions to ensure optimal headlight alignment:
 - Remove any ice or mud from under the fenders.

- Ensure that all tires are fully and evenly inflated.
- Check vehicle springs for sag or broken leaves.
- Check the function of any level ride controls.
- Stabilize the suspension by rocking the vehicle sideways.
- Ensure that there is no load in the vehicle other than the driver.
- Clean the headlights and matte white screen.

4. Mark the vertical vehicle centerline on the screen ([Figure 56](#)).

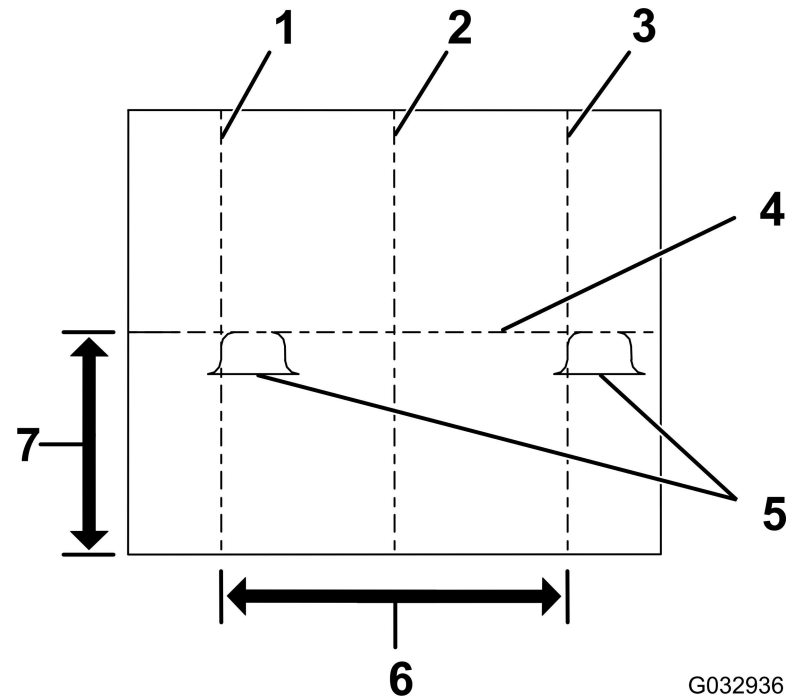

G032936
g032936

Figure 56

- | | |
|--|--|
| 1. Vertical left headlight centerline | 5. Brightest points |
| 2. Vehicle centerline | 6. Distance between headlight centers |
| 3. Vertical right headlight centerline | 7. Distance from ground to headlight centers |
| 4. Horizontal headlight centerline | |

5. Mark the vertical headlight centerline on the screen ([Figure 56](#)).
6. Mark the horizontal headlight centerline on the screen ([Figure 56](#)).
Note: The horizontal headlight centerline should be the distance from the ground to the center of the headlight.
7. Adjust the plow headlights until the brightest part of the plow low-beam lights are aligned as shown in [Figure 56](#).
8. Tighten the 4 bolts securing each headlight to the headlight brackets and torque them to 8 N·m (6 ft-lb).

Storage

Storing the Plow

1. Grease any exposed chrome or nitro bar on the plow-angle lift cylinders.
2. Drive the snowplow to your storage location and remove the plow; refer to [Removing the Snowplow \(page 42\)](#).
3. Power the coupler tower forward until the lift cylinder is completely compressed.
4. Apply dielectric grease to all of the wire-harness connectors and install the dust caps.
5. Lightly sand and use touch-up paint on painted areas that are scratched, chipped, or rusted.
6. Loosen the trip-return springs.
7. If you have a V-blade plow, loosen the blade-return springs.
8. Grease the coupler spring-pins.

9. If you have a V-blade plow, grease the vertical hinge bushings.

Removing the Plow from Storage

1. Check the plow for cracked welds.
2. Check the torque of all fasteners, pins, retainers, nuts, and bolts; tighten as necessary.
3. Check the hydraulic lines and hoses for cracks or leaks.
4. Replace the hydraulic fluid; refer to [Draining the Hydraulic Fluid \(page 48\)](#).
5. Check the cutting edge for wear.
6. Check the plow shoes for wear.
7. Tighten the trip-return springs.
8. If you have a V-blade plow, tighten the blade-return springs.
9. Lightly sand and use touch-up paint on painted areas that are scratched, chipped, or rusted.

10. Grease the coupler spring-pins.
11. If you have a V-blade plow, grease the vertical hinge bushings.
12. Apply dielectric grease to all of the wire harness connectors.
13. Attach the plow to the vehicle; refer to [Mounting the Snowplow \(page 32\)](#).
14. Move the plow through its range of motion to check the hydraulic cylinder rods.
15. Align the plow lights; refer to [Adjusting the Aim of the Plow Headlights \(page 63\)](#).

Troubleshooting

Problem	Possible Cause	Corrective Action
The pump motor does not run.	<ol style="list-style-type: none"> 1. The power/ground cables or control cables are not connected. 2. The pump motor has failed or the pump has seized 3. The cable between the battery and the solenoid is disconnected or broken. 4. The solenoid has failed. 5. Power from the relay is disconnected. 	<ol style="list-style-type: none"> 1. Connect the cables. 2. Check for voltage at the pump motor while the ignition switch is on and the Raise button is pressed on the controller. If voltage is present, the motor brushes or pump/motor assembly may be replaced. 3. Check for power to the solenoid by testing for voltage between both large terminals and ground. If voltage is not present between one large terminal and ground, connect or replace the cable. 4. Check for voltage between the other large terminal of the solenoid and ground while jumping power to the small terminal with the white/black wire. If no voltage is present, replace the solenoid. If voltage is present, connect or replace the wire from the small terminal of the solenoid to ground. 5. Test the voltage between the black wire and ground at the white 9-pin connector. If no voltage is present, connect the relay. If voltage is present, check the wiring and controller switches.

Problem	Possible Cause	Corrective Action
<p>The pump continues to run while the switch is in neutral.</p>	<ol style="list-style-type: none"> 1. The solenoid has failed in the closed position. 2. There is a short between the black and white/black wire in the controller. 3. The switch has failed. 	<ol style="list-style-type: none"> 1. Disconnect the controller and turn the ignition on. If the pump continues to run, quickly remove power to the pump by disconnecting the power/ground cables to the plow and replace the solenoid. 2. Disconnect the controller and turn the ignition on. If the pump stops running, replace the wire. 3. Replace the switch.

Problem	Possible Cause	Corrective Action
The plow does not lower.	<ol style="list-style-type: none"> 1. The power/ground cables or control cables are not connected. 2. The flow-control valve is closed. 3. The wiring on the valve block is not connected. 4. The solenoid valve or valve coil has failed. 5. Power from the relays is disconnected. 	<ol style="list-style-type: none"> 1. Connect the cables if they are not connected. 2. Place the controller in neutral, then open the flow-control valve. 3. Refer to the wiring schematic. 4. Check for voltage between the solenoid valve terminal and ground while the ignition switch is on and the controller is in the Float position. If voltage is present, replace the valve or valve coil. 5. Check the voltage between the black wire and ground at the white 9-pin connector. If no voltage is present, connect the relays. If voltage is present, check the wiring and switch off the controller.
The plow lowers too fast.	<ol style="list-style-type: none"> 1. The flow-control valve is open too much. 	<ol style="list-style-type: none"> 1. Close the flow-control valve to the desired drop speed.

Problem	Possible Cause	Corrective Action
<p>The plow does not raise or raises slowly.</p>	<ol style="list-style-type: none"> 1. The hydraulic-fluid level is low. 2. The power/ground cables or the control cable are not connected. 3. The wiring on the valve block is not connected. 4. The battery is weak or needs replacing. 5. The motor brushes are bad. 6. The pump pressure relief valve is set to less than 172 bar (2,500 psi), contaminated, or damaged. 7. The pump is worn 8. The Raise control solenoid valve is not opening completely. 9. The Lower control solenoid valve is stuck open. 	<ol style="list-style-type: none"> 1. Check the hydraulic-fluid level; refer to the Checking the Hydraulic Fluid section. 2. Connect the cables. 3. Refer to the wiring schematic. 4. Load a test battery and replace it if necessary. 5. Check the motor brushes and replace them if necessary. 6. Ensure that the pressure is set to 172 bar (2,500 psi). Check the pressure again. If it is less than 172 bar (2,500 psi) at the end of the lift, clean or replace the pressure relief valve. 7. Replace the pump. 8. Replace the valve. 9. Replace the valve.

Problem	Possible Cause	Corrective Action
The plow angles while plowing.	<ol style="list-style-type: none"> 1. The ANGLE control solenoid valve is contaminated or damaged. 2. The pressure relief valve is contaminated or damaged. 3. The pressure relief valve is set incorrectly. 	<ol style="list-style-type: none"> 1. Clean or replace the ANGLE control solenoid valve. 2. Clean or replace the pressure relief valve. 3. Contact your authorized BOSS dealer.
The plow does not angle or angles slowly.	<ol style="list-style-type: none"> 1. The hydraulic-fluid level is incorrect. 2. The power/ground cables and/or the control cables are not connected properly. 3. The wiring connections on the valve block are not connected properly. 4. The battery is damaged or depleted. 5. The ANGLE control solenoid valve does not open completely. 	<ol style="list-style-type: none"> 1. Ensure that the hydraulic-fluid level should be within 2 cm (3/4 inch) of the top of the reservoir when the plow is lowered. 2. Connect the cables if they are not connected. 3. Refer to the manifold wiring schematic included with your <i>Owner's Manual</i>. 4. Load a test battery and replace it if necessary. 5. Replace the ANGLE control solenoid valve.

Problem	Possible Cause	Corrective Action
Fluid leaks from the lift cylinders.	<ol style="list-style-type: none"> 1. The fittings are loose or the O-rings are damaged. 2. The rods are pitted or rough. 	<ol style="list-style-type: none"> 1. Tighten loose fittings. See your authorized BOSS dealer for a seal kit. 2. Polish them with a copus cloth or extra fine steel wool.
The vehicle battery dies when the vehicle is turned off.	<ol style="list-style-type: none"> 1. The wire harness isn't connected to a keyed fuse source. 	<ol style="list-style-type: none"> 1. Connect the wire harness to a keyed fuse source; refer to the wire schematic.
The vehicle battery dies when all of the switches are in the Neutral position.	<ol style="list-style-type: none"> 1. There is a short in the controller wiring. 2. There is a short in the wire harness. 3. There is a short in the valve coils. 	<ol style="list-style-type: none"> 1. Repair or replace the controller. 2. Repair or replace the wire harness. 3. Replace the valve coils.
The plow lights are dim, do not come on, or flicker.	<ol style="list-style-type: none"> 1. The electrical connections are corroded or damaged.. 2. The wrong headlight adapters are being used. 3. The headlight adapters are not installed correctly. 4. The relays are corroded or broken. 	<ol style="list-style-type: none"> 1. Clean and repair the terminals. 2. Replace the headlight adapters with the correct ones. 3. Correctly install the headlight adapters. 4. Clean or replace the relays.

Problem	Possible Cause	Corrective Action
The turn signals flash at a rapid rate.	<ol style="list-style-type: none"> 1. The wrong headlight adapters are being used. 2. The headlight adapters are not installed correctly. 3. The wrong flasher is being used. 	<ol style="list-style-type: none"> 1. Replace the headlight adapters with the correct ones. 2. Correctly install the headlight adapters. 3. Replace the vehicle flasher with a heavy-duty 6 A flasher.
There is no high-beam indicator light, or it does not function properly.	<ol style="list-style-type: none"> 1. The wrong headlight adapters are being used. 2. The headlight adapters are not installed correctly. 	<ol style="list-style-type: none"> 1. Replace the headlight adapters with the correct ones. 2. Correctly install the headlight adapters.
The blade trips too easily.	<ol style="list-style-type: none"> 1. The trip springs are loose or damaged. 2. The pushbeam is not at the correct height. 	<ol style="list-style-type: none"> 1. Tighten the springs or replace them if they are damaged. 2. Adjust the push beam to the proper height.
The plow does not clean up snow from low areas.	<ol style="list-style-type: none"> 1. The controller is not in the FLOAT position. 	<ol style="list-style-type: none"> 1. Activate the FLOAT feature on the controller.
Fluid is running out of the fill cap of the hydraulic pump.	<ol style="list-style-type: none"> 1. The terrain is too steep. 2. The pump reservoir is overfilled. 3. The plow is hitting snowbanks too hard. 	<ol style="list-style-type: none"> 1. Avoid steeply sloped areas. 2. The hydraulic fluid level should be within 2 cm (3/4 inch) of the top of the reservoir. 3. Do not plow recklessly.

Problem	Possible Cause	Corrective Action
The pump chatters when raising or angling the plow.	1. The hydraulic-fluid level is low.	1. Check the hydraulic-fluid level; refer to the Checking the Hydraulic Fluid section.
The SmartHitch2 does not attach to the plow.	<ol style="list-style-type: none"> 1. The controller is not in the FLOAT position. 2. The controller is malfunctioning. 3. The valve block and SmartHitch2 switch are not properly connected. 	<ol style="list-style-type: none"> 1. Turn the vehicle on and put the controller in the FLOAT position. 2. Replace the controller. 3. Check valve block and the SmartHitch2 switch for proper connections; refer to the manifold wiring diagram included with your <i>Owner's Manual</i>.
The plow lights and truck lights are on at the same time.	1. The vehicle wire harness is plugged into the vehicle headlight.	1. Check the wiring connections; refer to the wiring diagram included with your <i>Owner's Manual</i> .
All of the plow and vehicle lights are on at the same time.	1. The headlight adapters are not installed correctly.	1. Correctly install the headlight adapters.
While trying to raise the plow, the wing(s) extend prior to raising the plow and do(es) not retract.	1. The pressure or return lines are incorrectly routed.	1. Ensure that the pressure line is connected from the "P" on the pump to the "P" on the valve manifold, and the return line is connected from the "T" on the pump to the "T" on the valve manifold.

Problem	Possible Cause	Corrective Action
The wings drift back when extended.	<ol style="list-style-type: none"><li data-bbox="722 240 1299 311">1. The wing-return-solenoid valve on the manifold is contaminated.<li data-bbox="722 337 1205 409">2. The pressure-relief valve is contaminated.	<ol style="list-style-type: none"><li data-bbox="1352 240 1696 279">1. Clean or replace it.<li data-bbox="1352 337 1696 376">2. Clean or replace it.

Problem	Possible Cause	Corrective Action
<p>The wing(s) do(es) not extend or extend slowly when the motor runs.</p>	<ol style="list-style-type: none"> 1. The hydraulic-fluid level is low. 2. The power/ground cables or the control cable are not connected. 3. The wiring on the valve block is not connected. 4. The battery if it is weak or needs replacing. 5. The motor brushes are bad. 6. The pump pressure relief valve is set to less than 172 bar (2,500 psi), contaminated, or damaged. 7. The pump is worn 8. The Wing Out control solenoid valve is not opening completely. 9. The wiring or control box is not connected. 	<ol style="list-style-type: none"> 1. Check the hydraulic-fluid level; refer to the Checking the Hydraulic Fluid section. 2. Connect the cables. 3. Refer to the wiring schematic. 4. Load a test battery and replace it if necessary. 5. Check the motor brushes and replace them if necessary. 6. Ensure that the pressure is set to 172 bar (2,500 psi). Check the pressure again. If it is less than 172 bar (2,500 psi) at the end of the lift, clean or replace the pressure relief valve. 7. Replace the pump. 8. Replace it. 9. Refer to the wiring schematic.

Problem	Possible Cause	Corrective Action
The wing(s) extend, but do(es) not retract or retract slowly.	<ol style="list-style-type: none"> 1. The power/ground cables or control cable are not connected. 2. The wiring on the valve block is not connected. 3. The solenoid valve or valve coil has failed. 	<ol style="list-style-type: none"> 1. Connect the cables. 2. Refer to the wiring schematic. 3. Check for voltage between the solenoid valve terminal and ground while the ignition switch is on and the controller is in the Wing In position. If voltage is present, replace the valve or valve coil.
The plow wings do not extend or retract.	<ol style="list-style-type: none"> 1. If the status light on the plow module is green but not blinking, the controller is not communicating correctly. 2. If the status light on the plow module is orange, the plow module may be wired incorrectly. 3. If the status light on the plow module is blinking orange or red, there is a problem with the module driver. 4. If the status light on the plow module is off, the plow module is not getting power. 	<ol style="list-style-type: none"> 1. Check the controller connections. Replace the controller if it is broken. 2. Refer to the wiring diagram included with your <i>Owner's Manual</i>. 3. Check the module connections for shorts. Replace the module if it is broken. 4. Check that the controller is on and that all of the plugs are connected.

Problem	Possible Cause	Corrective Action
The wing(s) retract too easily while plowing.	1. The pressure-relief valve pressure is set too low.	1. See an authorized BOSS dealer for pressure-relief-valve adjustment.
The blade digs into the ground in the V position.	1. The bumper stop is not in the correct position. 2. The pushbeam is installed too high.	1. Adjust the bumper-stop position. 2. Lower the pushbeam.
The blade does not lay flat on the ground in the scoop position.	1. The bumper stop is not in the correct position. 2. The pushbeam is installed too low.	1. Adjust the bumper-stop position. 2. Raise the pushbeam. If the pushbeam is at the highest setting, adjust the bumper stop further into the center section.

BOSS

S N O W P L O W