

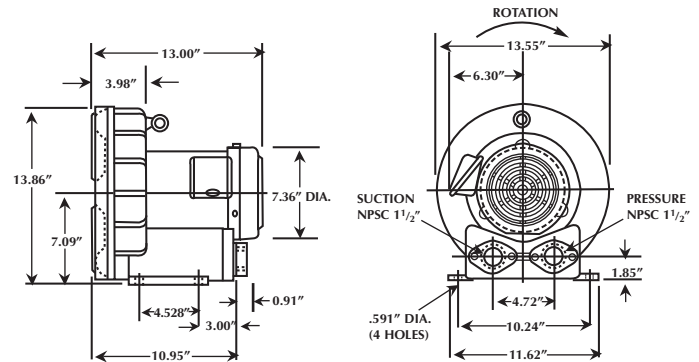

The VFC50 is a singlestage ring compressor with a maximum pressure of 80 in. H₂O, a maximum vacuum of 70 in. H₂O, and a maximum capacity of 154 SCFM. It comes complete with a direct-drive, 2.5 horsepower, TEFC motor capable of operating on a wide range of voltages, and on 50 or 60 Hz. A pilot-duty thermal protector is standard equipment on all 3-phase and 1-phase models. All versions have NEMA class B insulation, are UL recognized, CSA certified, and CE. 575 Volt units are CSA certified only.



SPECIFICATIONS

Model No.	Hz	Voltage	Amps		Max. Pressure	Max. Vacuum	Max. Airflow	Min. Airflow	Max. Temp Rise (ΔT)	Weight
			(Max. Rated)	(Locked Rotor)						
1 Phase VFC508P-2T	60	200/230	12-11	70-80	80	70	154	60	72(40)	97.5(44)
	50	200/230	8.5-8	70-75	60	53	130	45	65(35)	
3 Phase VFC500A-7W	60	200-240/400-480	6.9-6.2/3.4-3.1	44-52/22-26	80	70	154	45	101(55)	70.5(32)
	50	190-230/380-460	5.2-5.4/2.6-2.7	48-56/24-28	60	53	130	25	72(40)	
VFC500A-5W	60	575	2.3	21	80	70	154	45	119(65)	70.5 (32)

ACCESSORIES

Description	Vacuum Relief Valve	Pressure Relief Valve	Inlet Filter	Inlet Filter Cover	Inlet Filter/Receiver	Exhaust Silencer/Muffler
Model No.	VV5	PV5	F-45	C-45	R30P1.5	VFY-024A



NOTE: Maximum allowable time at deadhead is 60 seconds.