

**HARMSCO®**

# Betterfilter®

## INSTALLATION AND OPERATION MANUAL UPFLOW SWIMMING POOL CARTRIDGE FILTER

### CARTRIDGE CLEANING INSTRUCTIONS

#### HARMSCO CARTRIDGES

May be cleaned and reused before replacement is necessary.  
Cartridge cleaning is necessary only when flow falls below that required or  
when pressure increase over start-up pressure exceeds 10 pounds.

#### INSTRUCTIONS FOR CLEANING CARTRIDGES

See Page 4 on how to remove and replace cartridge(s) for cleaning.  
Remove rim gasket to prevent damage during cleaning.

#### Normal Cleaning Procedure.

Normal cleaning is done by using a pressure nozzle on the end of your garden hose. Direct jet spray at cartridges on an angle to remove dirt.

#### Special Cleaning Procedures.

To be used only when normal procedure is insufficient to return cartridge to normal filter runs.

**1 Removing Oils From Cartridges.** If oils coat cartridges and cause reduced flow, this material may be removed by soaking cartridges in a solution of 2 lb. Tri-sodium Phosphate to 10 gallons of water or a Tri-sodium Phosphate based product. Usually 12 hours soaking time will break oil coating from cartridge. Enzyme products are known to release oils from cartridge media and in **some** cases may eliminate the need for soaking. Tri-sodium Phosphate and enzyme products are available at most swimming pool distributors and retail locations. Repeat Normal Cleaning Procedure.

**2 Removing Algae From Cartridges.** If algae coats the cartridges and causes reduced flow, soak cartridges in a solution of 2 lb. Tri-sodium Phosphate to 10 gallons of water. Add 1 pint of swimming pool chlorine to kill the algae. Soak for one hour. Check pool chemistry for cause of algae growth.

**3 Removing Calcium Or Mineral Deposits. \*\*\*Caution\*\*\*** Do not use muriatic acid on cartridges until all oils have been removed as in step #1 above. Make sure all previously used products have been thoroughly rinsed from cartridges.

If calcium deposits are present, perform operation #1 above. Rinse - then, in a solution of 1 part muriatic acid to 20 parts water, soak until bubbling action stops. Use a plastic garbage container or similar vessel. Check pool chemistry for high PH or Alkalinity. Repeat Normal Cleaning Procedure.

**4** The only exception to the above procedures are with the use of biguanides (i.e. Baquacil, SoftSwim or other similar sanitizer). When using a biguanide, always soak the cartridge with muriatic acid first (as described in #3), and then soak in Tri-sodium Phosphate and water, (as described in #1).

Heed all manufacturer's posted instructions, warnings and cautions  
when using any product.

## TYPICAL INSTALLATION OF RESIDENTIAL POOLS

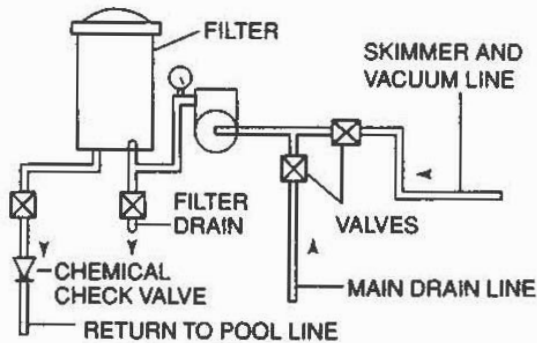

Where unit is being installed below water level of the pool, it is necessary to provide valves as indicated in the drawing as shown, so that the filter housing may be opened without draining the pool.

To protect against electrolysis, all metal components of the water circulation and heating systems must be connected by a wire to ground the entire system.

**Filter housings must be grounded**  
**DO NOT STORE CHEMICALS NEAR FILTER HOUSING**

### TYPICAL INSTALLATIONS\*

For Residential and Commercial Pools

\* See Page 6 for Single Cartridge (SC) Models

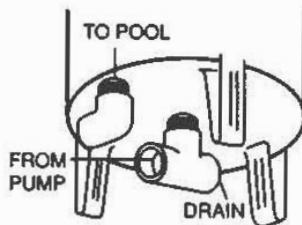

FIG 1:  
 Betterfilter® Models  
 BF42, BF84,  
 BF126

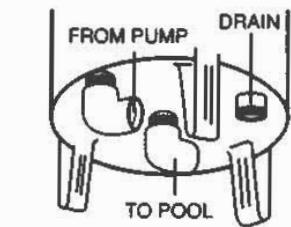

FIG 2:  
 Betterfilter® Models  
 BF96, BF144

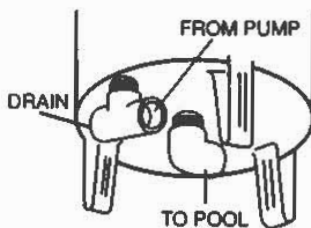

FIG 3:  
 Betterfilter® Models  
 BF168, BF252,  
 BF336, BF450,  
 BF600

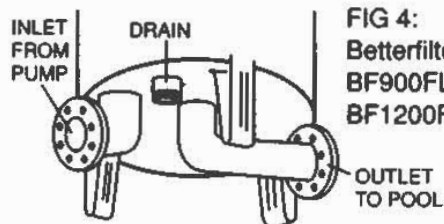

FIG 4:  
 Betterfilter® Models  
 BF900FL,  
 BF1200FL

#### SUGGESTED INSTALLATION (Fig. 1)

1. Install 1-1/2" "T" on the center nipple as shown in figure 1.
2. Pipe water from discharge of pump to one side of this "T".
3. Install a 1-1/2" x approximately 10" nipple from other side of this "T" with 1-1/2" valve at end of nipple. This is for draining filter unit.
4. Install 1-1/2" elbow on the other nipple as illustrated. This is the return-to-pool line.

#### SUGGESTED INSTALLATION (Fig. 2)

1. Install 2" thread to socket PVC elbows on side of nipple marked inlet—Pipe water from pump discharge to this elbow.
2. Install 2" thread to socket PVC elbow on center nipple marked outlet. This is the return to pool line.
3. Install 1" valve or cap on marked drain.

#### SUGGESTED INSTALLATION (Fig. 3)

1. Install thread to socket "T" on the side nipple as shown in figure 3. Pipe water from discharge of pump to one side of this "T".
2. Install nipple and valve in other side of this "T". This is the drain for emptying filter housing.
3. Install thread to socket PVC elbow on center outlet. This is the return-to-pool line.

#### SUGGESTED INSTALLATION (Fig. 4)

1. Install water pipe from the pump to flange marked "inlet".
2. Pipe return-to-pool line flange marked "outlet".
3. Install valve in drain line to threaded nipple marked "drain".

**Operation:** After installation insure all in-line valves are in the open, flow through position. Turn on pump. **WARNING:** Inlet pressure not to exceed 50 psi. Operating temperature: 32° - 105°F.

## ASSEMBLY INSTRUCTIONS FOR BKM BASE MODELS

Models: BF144 BKM, BF105 BKMSC and BF155 BKMSC are 2"

Models: BF42 BKM, BF84 BKM, BF126 BKM are 1-1/2"

Harmsco base kit models are adaptable to different swimming pool pumps.

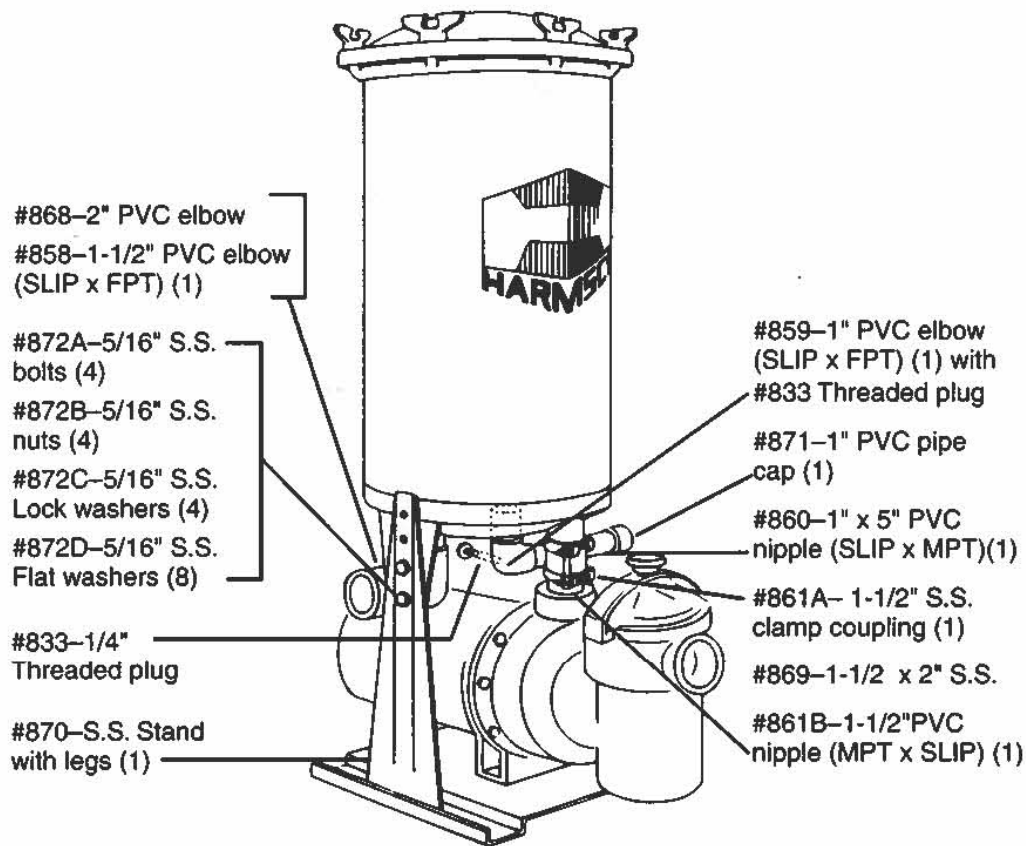

All other parts are the same as equivalent BF Models

**STEP 1.** Read instructions thoroughly and familiarize yourself with parts. (Cartridge cluster may be removed during assembly).

**STEP 2.** Install the 1-1/2" nipple (MPT x SLIP) (#861B) into top of pump using teflon tape. Slip the 1-1/2" S.S.\* clamp coupling (#861A) onto the nipple, tighten bottom bolt only.

**STEP 3.** Turn filter tank upside down and install 1-1/2" PVC elbow (SLIP x FPT) (#858) onto S.S.\* outlet nipple of filter tank. Tighten to desired position.

**STEP 4.** Install 1" PVC elbow (SLIP x FPT) (#859) onto S.S.\* drain nipple of filter tank, tighten to desired position. Glue slip end of 1" PVC nipple (#860) into elbow. Install 1" PVC pipe cap (#871) onto 1" PVC nipple (#860) using teflon tape.

**STEP 5.** Position filter tank in between base kit legs and insert S.S.\* inlet nipple of filter (located directly below name plate decal) into top section of the S.S.\* clamp coupling (#861A). Keeping filter tank level, install 2 S.S.\* 5/16" bolts (#872A), nuts (#872B) and washers (#872C) on each side of stand, using a 1/2" wrench to secure filter tank to stand.

**STEP 6.** Tighten S.S.\* coupling (#861A) top bolt.

**STEP 7.** Screw 1/4" threaded plug (#833) into hole in 1" PVC elbow (#859) which is attached to the drain nipple (or install pressure gauge, not supplied, into the hole in the elbow).

#- Part Number \*- Stainless Steel

## ASSEMBLY INSTRUCTIONS FOR BKP PORTABLE MODELS

Assembly is the same as for BKM Models except for the following:

Proceed exactly as with BKM before Step 5.

1. Slip bolts through holes in accessory bracket before proceeding to tighten nuts, etc.
2. Slide axle into holes on axle bracket.
3. Slip one (1) washer on each side of axle before putting on wheels.
4. Slip on wheels with grease fittings to the outside.
5. Add one washer to axle on each side and then slip cotter pins in place on each side of axle.

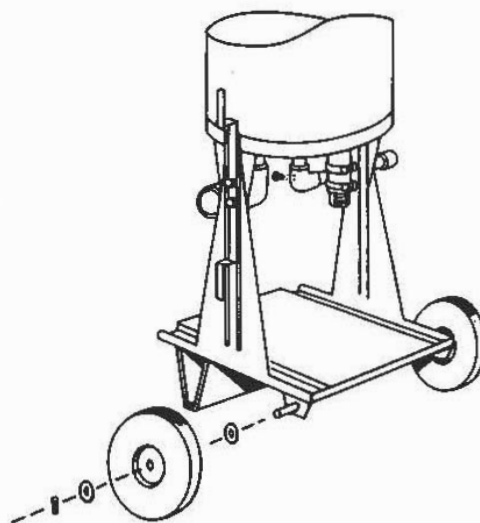

**\*\*WARNING\*\*** Electrical wiring must be done by a qualified electrician to federal, state, and local codes. A ground fault circuit interrupter must be installed at receptacle to protect all electrical components.

All electrical components specified and supplied by others.

### HOW TO REMOVE AND REPLACE CARTRIDGE CLUSTER FOR CLEANING

on residential Betterfilter® Models BF42, BF84, BF96, BF126, BF144 and Models BF42 BKM, BF84 BKM, BK96 BKM, BF126 BKM, BF144 BKM and the Model BKP Portable Filter

1. Turn off pump.
2. Unscrew wing nuts, lift lid from filter.
3. Remove cartridge cluster from housing
4. Clean cartridge cluster as described on cover.
5. Return cluster to housing. Replace gaskets properly.
6. Grease studs; replace wing nuts, hand tighten securely.

### How To Install New Cartridges

1. Follow above steps to remove cartridge cluster from filter housing.
2. Unscrew special straight threaded pipe cap from bottom of cartridge holding rod.
3. Slip spent cartridges from cartridge holding rod.
4. Slip new Harmsco cartridges on cartridge holding rod.
5. Replace special straight threaded pipe caps and tighten by hand so that cartridges are properly sealed.
6. Follow above steps for replacing cartridge cluster in filter housing.

**DO NOT STORE CHEMICALS NEAR FILTER HOUSING**

## SINGLE AND MULTIPLE BETTERFILTER® COMMERCIAL INSTALLATION

### Schematic Diagram of Typical Commercial Pool Installation

- A. Main Drain Line Valve
- B. Vacuum Cleaning Valve
- C. Return-to-Pool Valve
- D. Pump-to-Filter Valve
- E. Pump-to-Drain Valve
- F. Filter Drain Valves
- G. Skimmer Line Valve

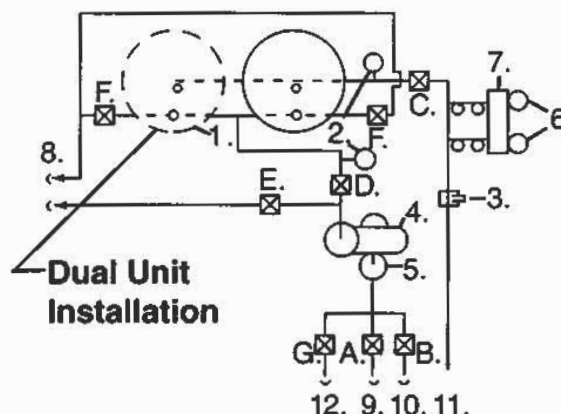

- |  |   |
|--|---|
| 1. Filter Housing(s)                                     | 6. Chemical Crock                       |
| 2. Pressure Gauges 2-1/2" Face-0-60 PSI                  | 7. One Double or Two Single Head Feeder |
| 3. Flow Rate Indicator-Post Filter Installation Required | 8. Filter Housing Drain Line            |
| 4. Pump and Motor  | 9. Pool Main Drain Line                 |
| 5. Hair and Lint Strainer -To Meet Code Requirements     | 10. Pool Vacuum Line                    |
|  | 11. Return to Pool Line                 |
|  | 12. Skimmer Line                        |

### All Filter Housings Must Be Grounded

To protect against electrolysis, all metal components of the water circulation and heating systems must be connected by a wire to ground the entire system.

### HOW TO REMOVE AND REPLACE CARTRIDGES ON BETTERFILTERS 168, 252, 336, 450, 600, 900FL, 1200FL

- |   |   |
|---|---|
| <p>1. Turn off pump. 2. Drain filter housing. 3. Unscrew wing nuts. 4. Lift lid from filter. 5. Remove top stainless steel plate from unit. 6. Take off top rubber seal. 7. Lift out cartridge lifters (with cartridges) from filter housing. 8. Clean cartridges (See cover for cleaning instructions). 9. Return car-</p> | <p>tridge lifters (with cartridges) to housing. 10. Re-place rubber top seal properly. 11. Put stainless steel plate in place. 12. Replace lid. 13. Grease studs. 14. Replace wing nuts, alternately tightening nuts on opposite sides. 15. Close drain valve. 16. Put filter back service.</p> |
|---|---|

**DO NOT STORE CHEMICALS NEAR FILTER HOUSING**

## REPLACEMENT PARTS AND ILLUSTRATION

### Betterfilter® Models BF55 SC, BF105 SC, BF155 SC

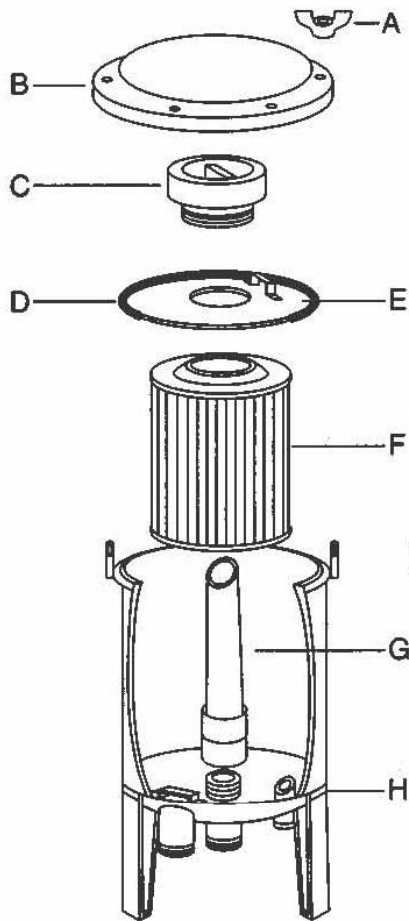

- A. Wing Nut
- B. Lid
- C. Cartridge Retainer Nut
- D. Rim Gasket
- E. Top Plate
- F. Cartridge
- G. Standpipe
- H. Tank

Note: Number of parts required per filter are in parenthesis

MODEL NUMBER			
	BF55 SC	BF105 SC	BF155 SC
A.	(6)202	(6)202	(6)202
B.	(1)530	(1)530	(1)530
C.	(1)905	(1)905	(1)905
D.	(1)550	(1)550	(1)550
E.	(1)903	(1)903	(1)903
F.	(1)ST55	(1)ST105	(1)ST155
G.	(1)562	(1)563	(1)564
H.	(1)55TK	(1)105TK	(1)155TK

#### SUGGESTED INSTALLATION

1. Install 2" thread to socket PVC elbows on side of nipple marked inlet—Pipe water from pump discharge to this elbow.
2. Install 2" thread to socket PVC elbow on center nipple marked outlet. This is the return to pool line.
3. Install 1" valve or cap on marked drain.

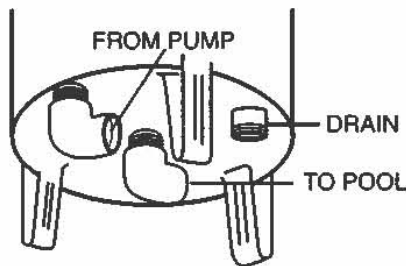

#### TO INSTALL NEW CARTRIDGES

1. Turn off pump.
2. Remove wing nuts, lift lid from filter.
3. Remove cartridge (with top plate) from filter. Unscrew cartridge retainer nut from cartridge.
4. Apply wax or vaseline to threads on new cartridge. Screw cartridge retainer nut through top plate into cartridge.
5. Tighten until top of cartridge fits snugly against bottom of top plate
6. Reassemble filter.

## RESIDENTIAL BETTERFILTER® REPLACEMENT PARTS

### Betterfilter® Models BF42, BF84, BF96, BF126, BF144

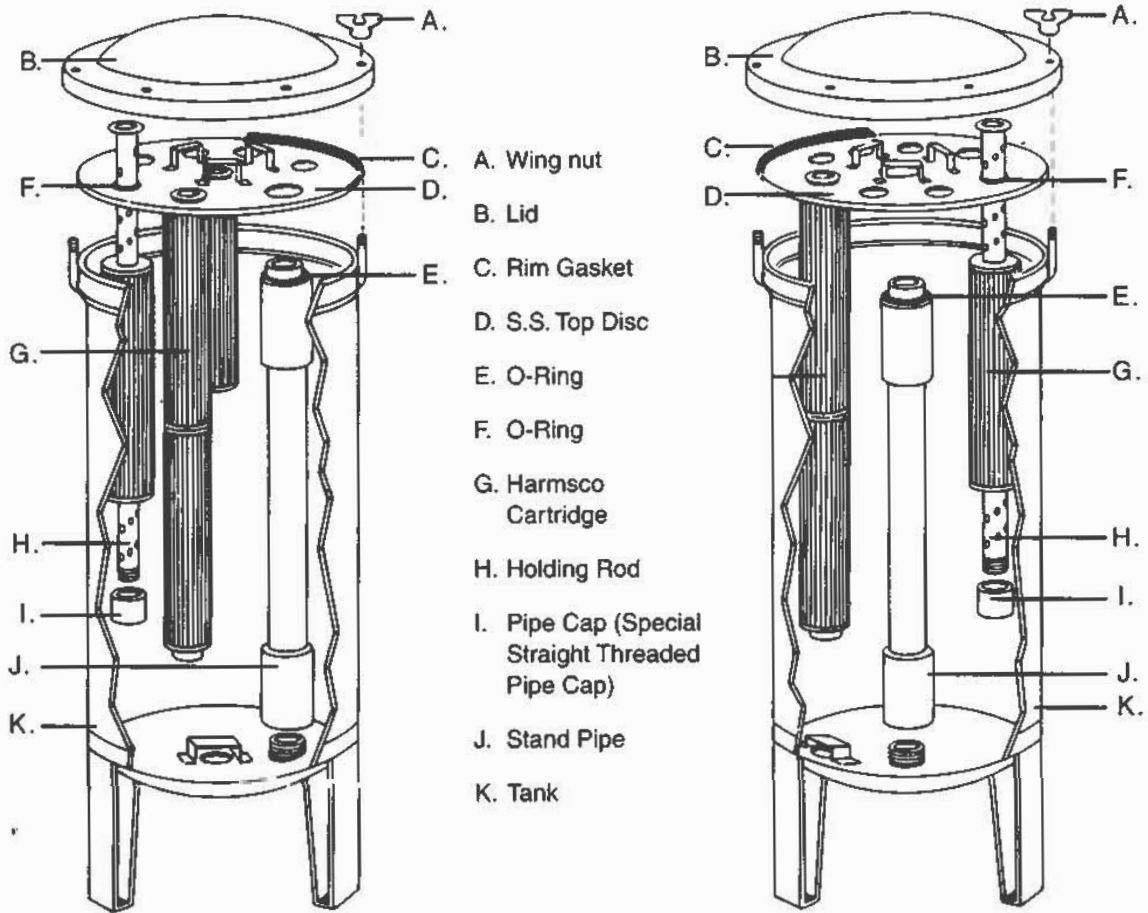

Note: Number of parts required per filter are in parenthesis

<b>MODEL NUMBER</b>					
	<b>BF42</b>	<b>BF84</b>	<b>BF96</b>	<b>BF126</b>	<b>BF144</b>
A.	(6)202	(6)202	(6)202	(6)202	(6)202
B.	(1)530	(1)530	(1)530	(1)530	(1)530
C.	(1)550	(1)550	(1)550	(1)550	(1)550
D.	(1)519	(1)519	(1)901	(1)519	(1)901
E.	(1)551	(1)551	(1)930	(1)551	(1)930
F.	(7)552	(7)552	(8)552	(7)552	(8)552
G.	(7)ST/6	(14)ST/6	(16)ST/6	(21)ST/6	(24)ST/6
H.	(7)555	(7)512	(8)512	(7)534	(8)534
I.	(7)513	(7)513	(8)513	(7)513	(8)513
J.	(1)560	(1)531	(1)965	(1)532	(1)1445
K.	(1)42TK	(1)84TK	(1)96TK	(1)126TK	(1)144TK

**BETTERFILTER® MODELS BF42 BKM, BF84 BKM, BF96 BKM,  
BF126 BKM, BF144 BKM, BF105 BKMSC, BF155 BKMSC,**

For parts A through K see corresponding BF model number

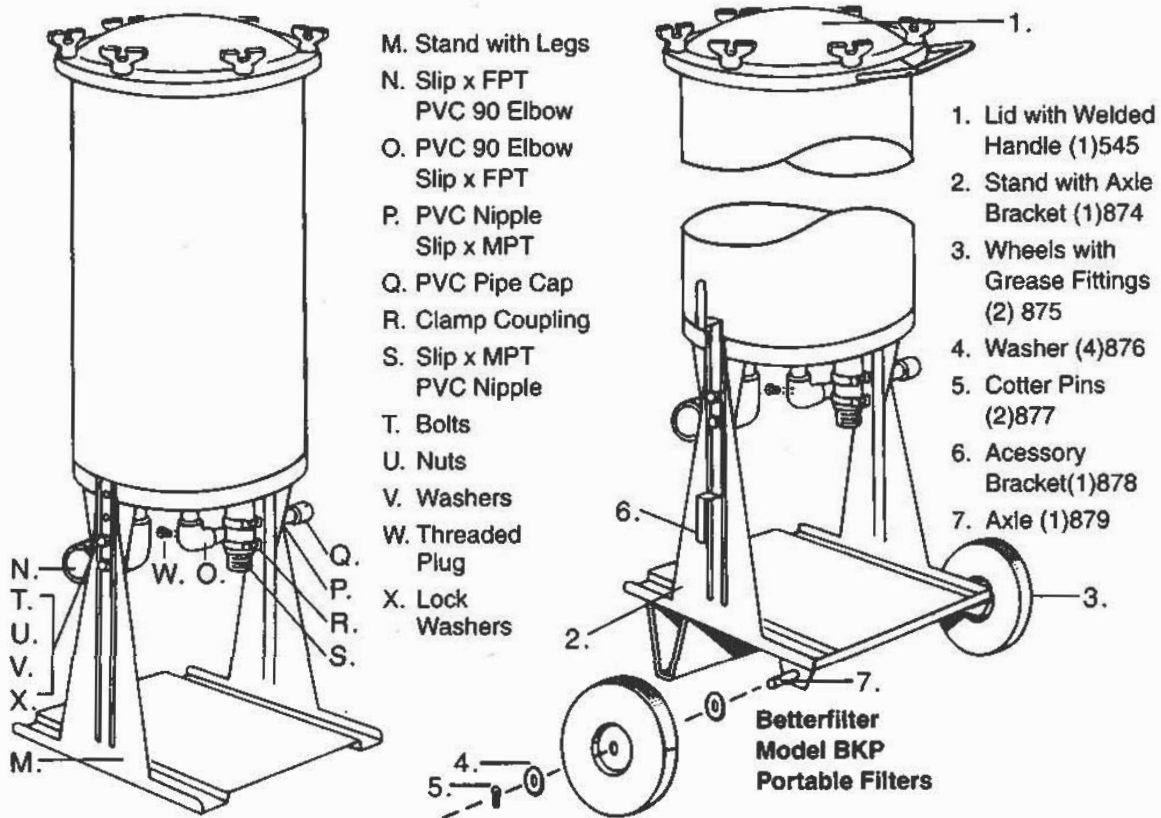

MODEL NUMBER					
	BF42 BKM	BF84 BKM	BF105 BKMSC BF96 BKM	BF126 BKM	BF105 BKMSC BF144 BKM
M.	(1)870	(1)870	(1)870	(1)870	(1)870
N.	(1)858	(1)858	(1)868	(1)858	(1)868
O.	(1)859	(1)859	(1)859	(1)859	(1)859
P.	(1)860	(1)860	(1)860	(1)860	(1)860
Q.	(1)871	(1)871	(1)871	(1)871	(1)871
R.	(1)861A	(1)861A	(1)869	(1)861A	(1)869
S.	(1)861B	(1)861B	(1)861B	(1)861B	(1)861B
T.	(4)872A	(4)872A	(1)872A	(4)872A	(4)872A
U.	(4)872B	(4)872B	(4)872B	(4)872B	(4)872B
V.	(8)872D	(8)872D	(8)872D	(8)872D	(8)872D
W.	(1)833	(1)833	(1)833	(1)833	(1)833
X.	(4)872C	(4)872C	(4)872C	(4)872C	(4)872C



## COMMERICAL BETTERFILTER® REPLACEMENT PARTS

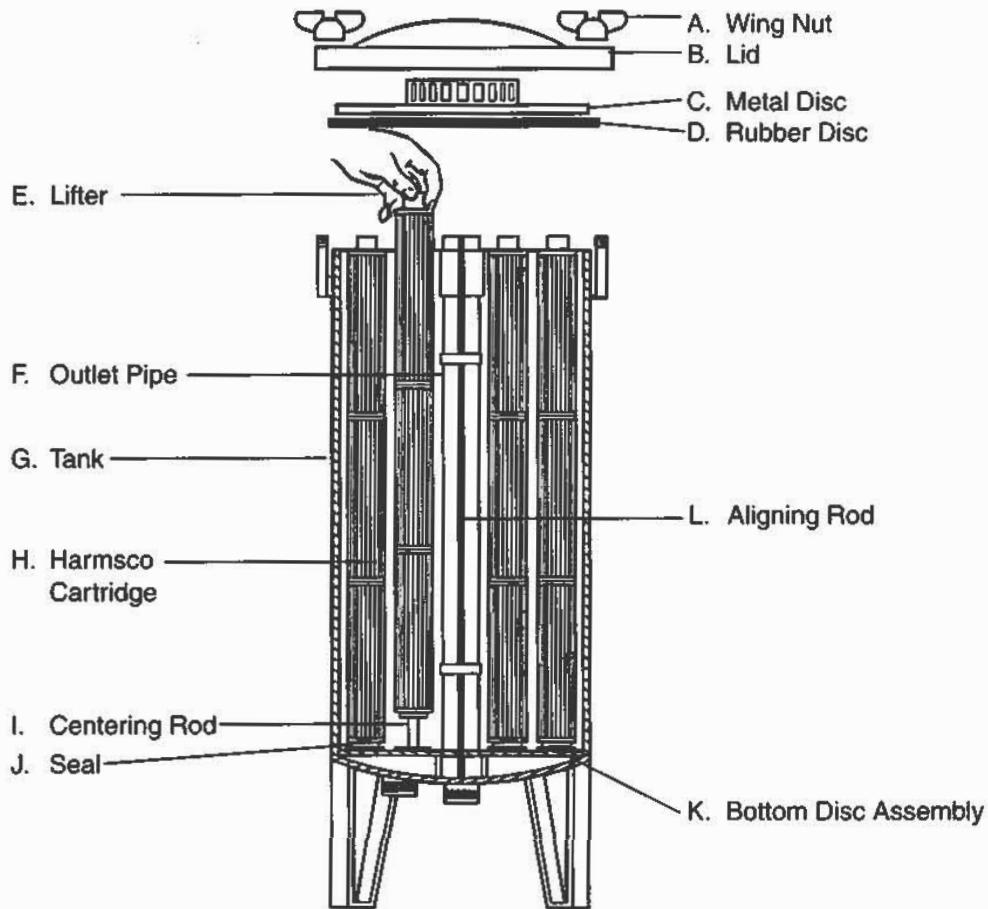

Note: Number of parts required per filter are in parenthesis.

MODEL NUMBER							
	BF168	BF252	BF336	BF450	BF600	BF900FL*	BF1200FL*
A.	(8)202	(8)202	(8)202	(10)202	(10)202	(20)202	(20)202
B.	(1)611	(1)611	(1)611	(1)669	(1)669	(1)613	(1)613
C.	(1)633	(1)633	(1)634	(1)670	(1)670	(1)651	(1)651
D.	(1)635	(1)635	(1)636	(1)671	(1)671	(1)653	(1)653
E.	(14)621	(14)622	(14)623	(25)622	(25)623	(50)622	(50)623
F.	(1)629	(1)630	(1)673	(1)672	(1)673	(1)646	(1)647
G.	(1)168TK	(1)252TK	(1)336TK	(1)450TK	(1)600TK	(1)900TK	(1)1200TK
H.	(28)ST/6	(42)ST/6	(56)ST/6	(75)ST/6	(100)ST/6	(150)ST/6	(200)ST/6
I.	(14)625	(14)625	(14)625	(25)625	(25)625	(50)625	(50)625
J.	(14)639	(14)639	(14)639	(25)639	(25)639	(50)639	(50)639
K.	(1)637	(1)637	(1)637	(1)677	(1)677	(1)638	(1)638
L.				(1)678-3	(1)679-3	(1)678-4	(1)679-4

\*BF900FL and BF1200FL have flange fittings instead of thread fittings.

# Performance Curves

## BF42A

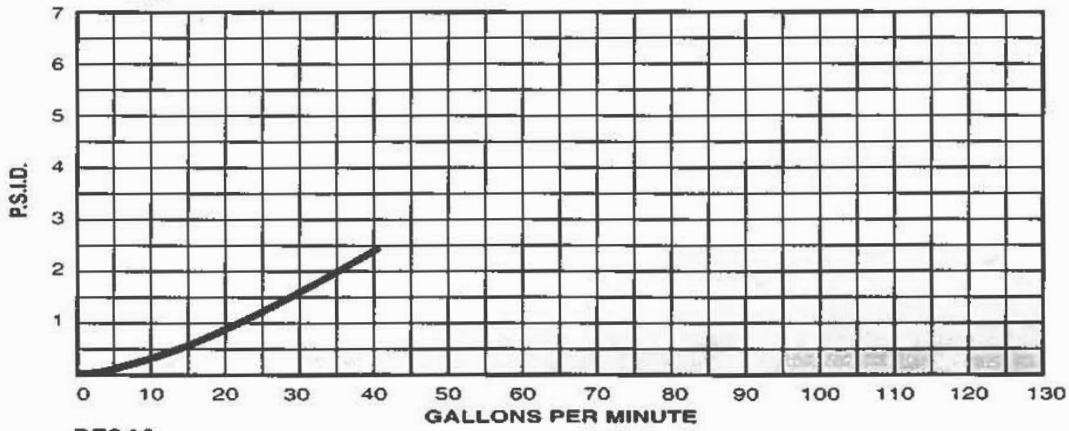

## BF84A

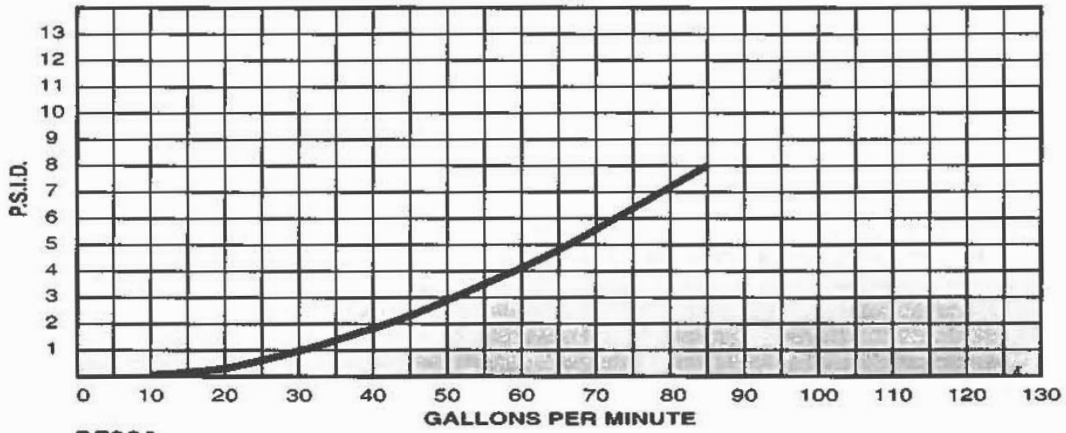

## BF96A

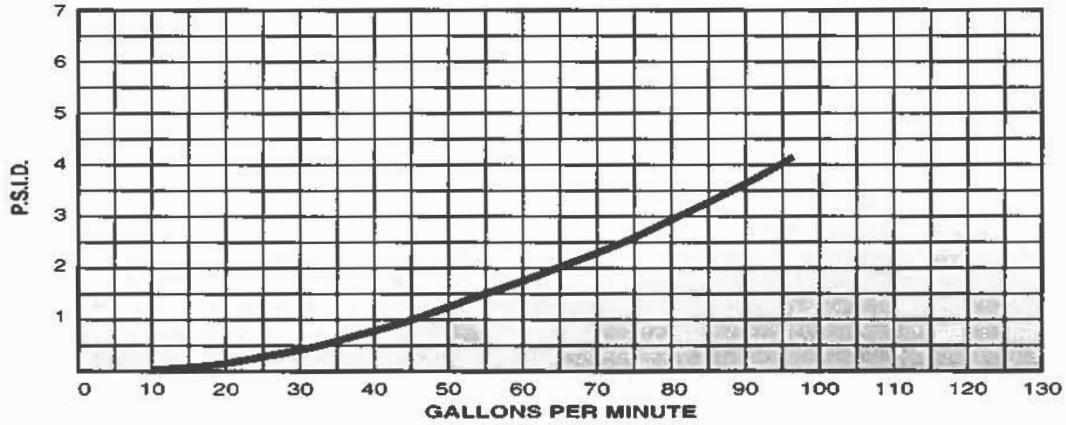

## BF126A

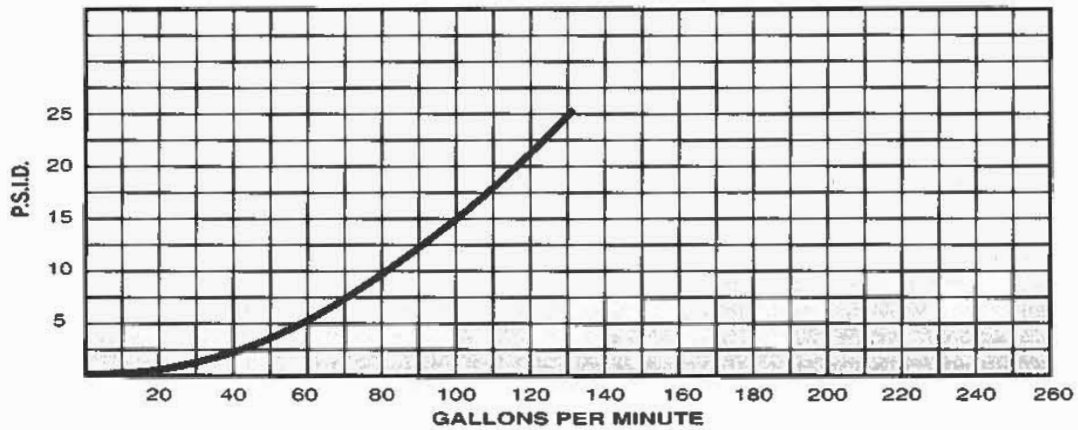

# Performance Curves

## BF144A

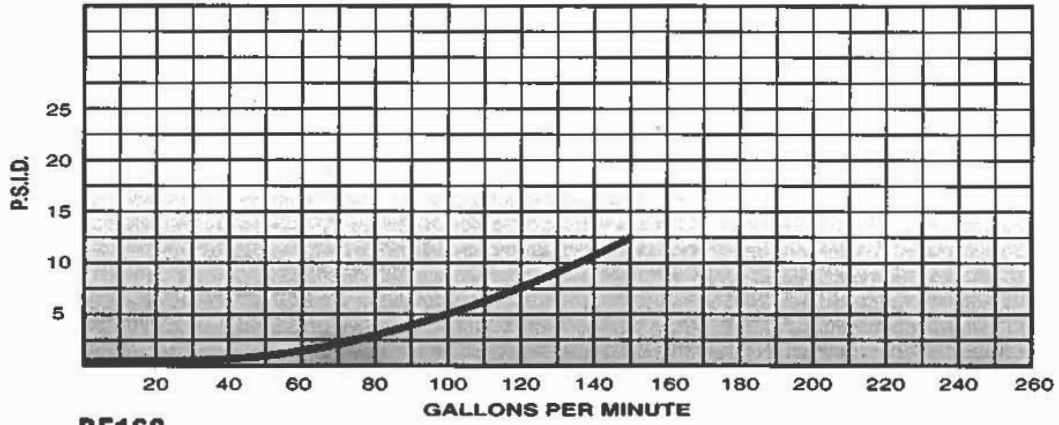

## BF168

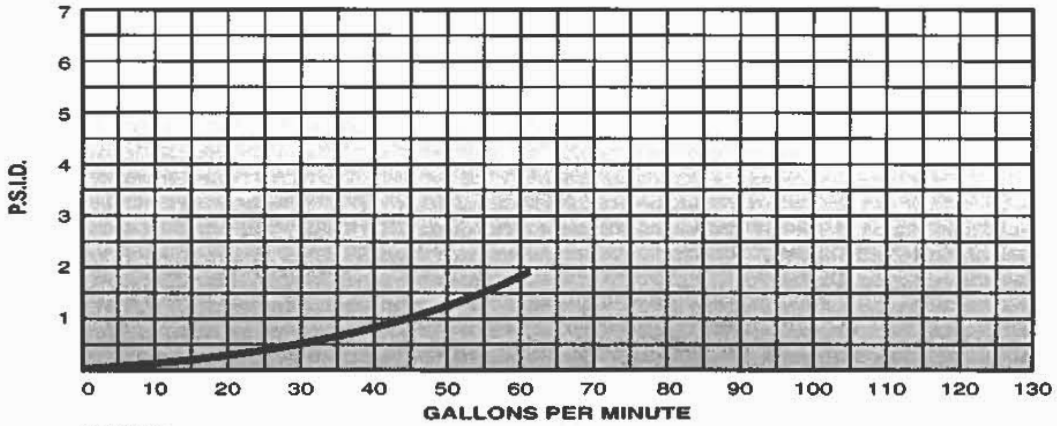

## BF252

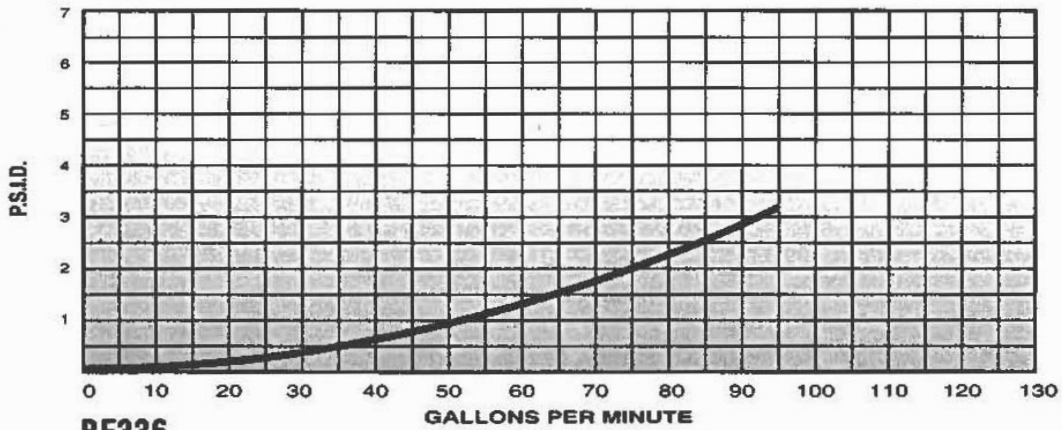

## BF336

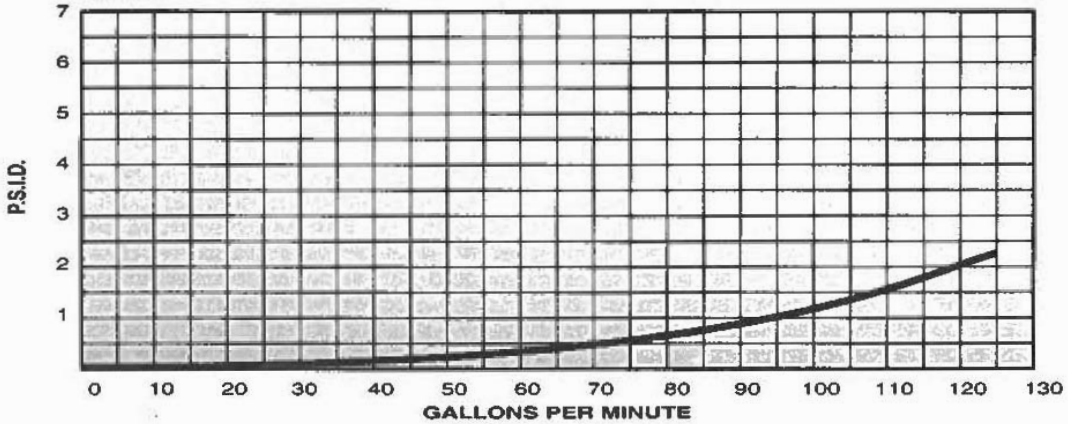

# Performance Curves

**BF450**

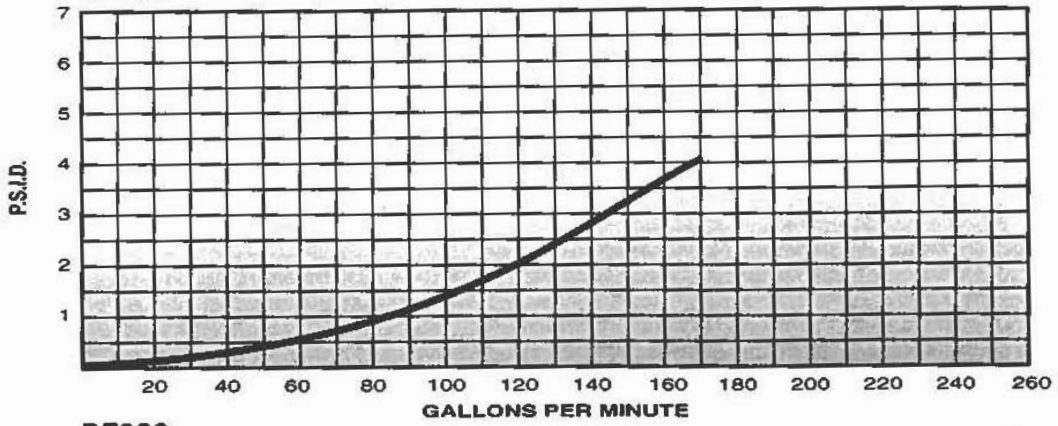

**BF600**

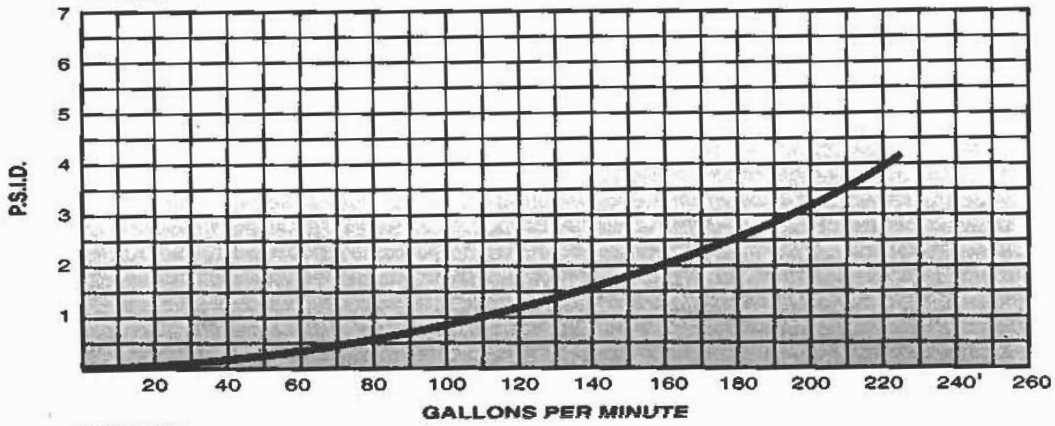

**BF900FL**

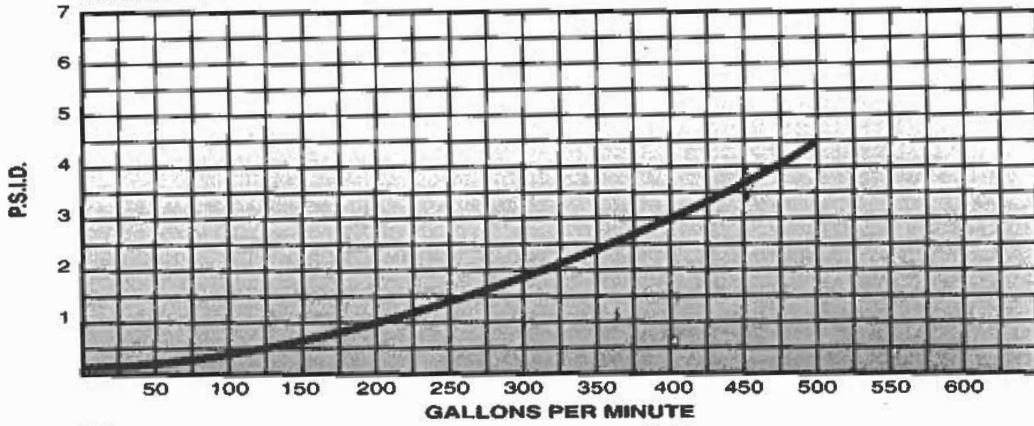

**BF1200FL**

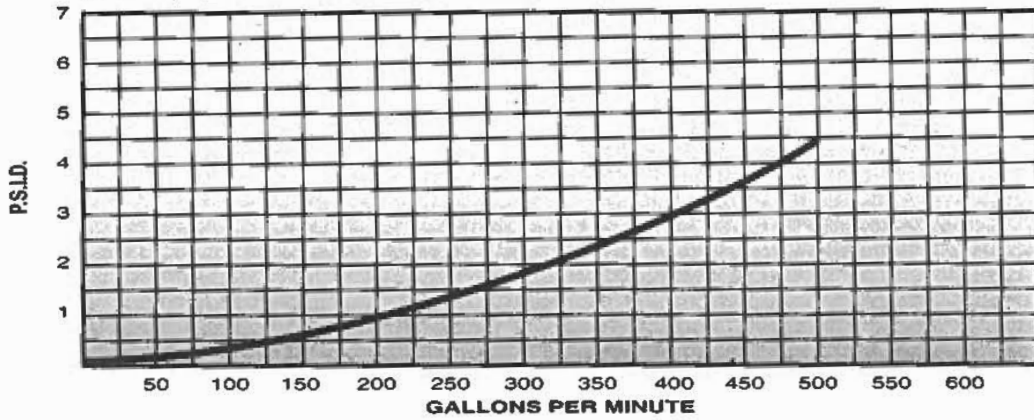

# Performance Curves

## BF55SCA

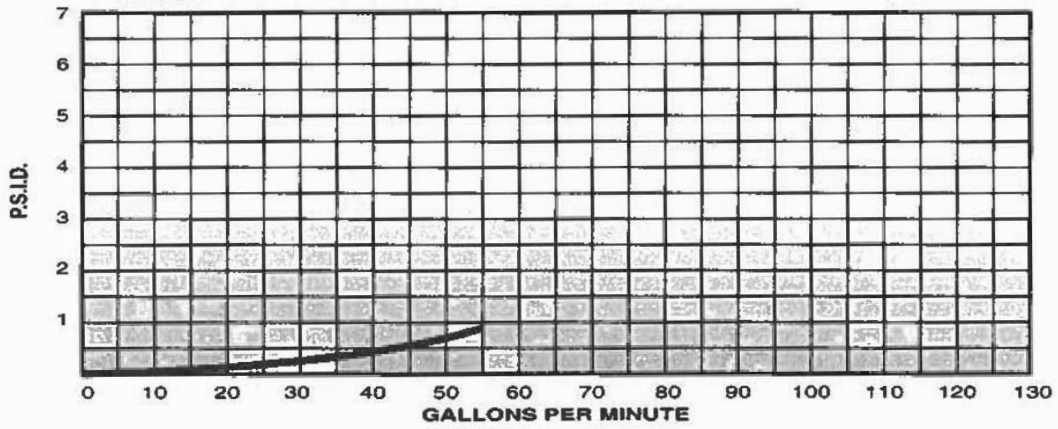

## BF105SCA

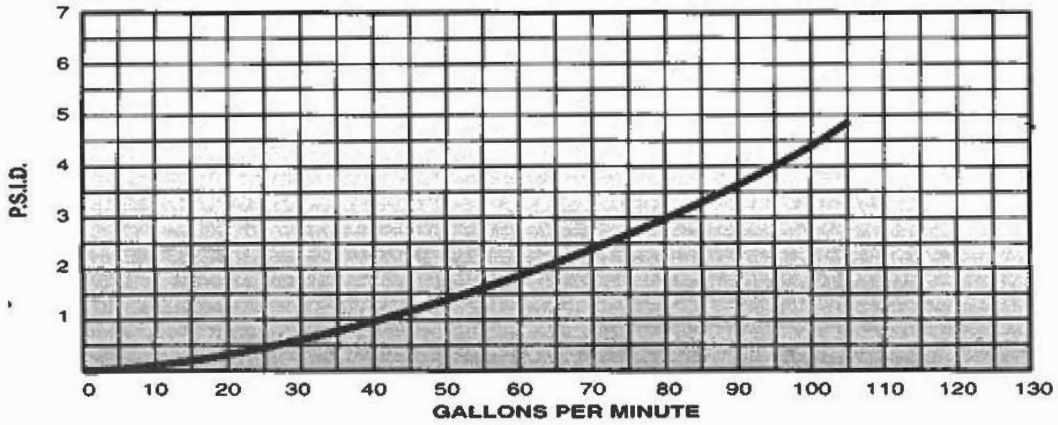

## BF155SC

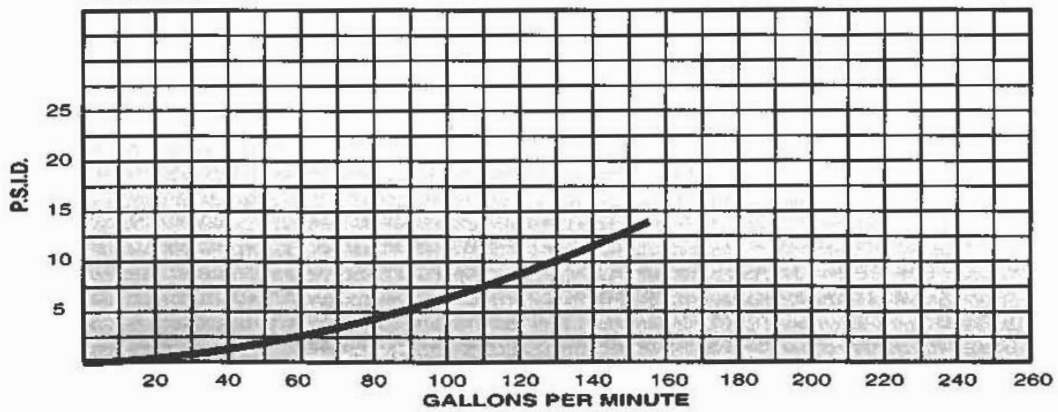

# WARRANTY

## HARMSCO® INC. LIMITED WARRANTY UPFLOW SWIMMING POOL CARTRIDGE FILTER

I. Harmsco, Inc. extends this warranty to the original purchaser of the filter unit only, provided that the "warranty information card" is completed and returned to Harmsco, Inc. within thirty (30) days of installation of the filter unit.

The filter unit is warranted against all defects in material and workmanship for the first year. During that year Harmsco will pay factory labor and parts for repair of the unit, together with shipping charges to and from the factory, provided proper shipping instructions have first been obtained from the factory.

**This warranty excludes the following:**

1. Any fresh water unit installed for sea water use.
2. Defects caused by improper installation, operation or care.
3. Damage caused by chemicals. (We strongly discourage the storage of chemicals or the use of chemical feeders near your unit). Make sure adequate ventilation is provided. If you can not comfortably breathe in closed pump room, ventilation is not adequate.
4. Gasket, wing nuts, top plates, bottom plates, cartridge lifter or holding rods, cartridges, outlet pipes, PVC fittings.
5. The cost of labor and material expended in removal and reinstallation of the unit.
6. Damage caused by electrolysis or galvanic attack.
7. Damage caused by salt added to the water for the purpose of generating chlorine.
8. Any unit not grounded / bonded.

II. Service under this warranty is to be provided by the dealer who sold the unit. If the dealer can not service the unit, please contact the factory: HARMSCO, INC., 7169 49th Terrace N, Riviera Beach, FL 33407  
ATTN: Service Dept. (561) 848-9628.

**Please be prepared with the following information:**

- Model number of your filter
- Date of installation
- Name of installer
- Nature of problem
- Your address and telephone number

Factory repair may be obtained by shipping your unit to the factory after first obtaining proper shipping instructions from the factory. The shipping charges are the purchaser's obligation, unless the unit has been installed for less than one year, in which event Harmsco will pay the charges. The shipping address is:

HARMSCO, INC.  
7169 49th Terrace North  
Riviera Beach, FL 33407

Any unit shipped to the factory must have all piping removed or a labor charge (at the then prevailing rate) will be made for removal.

A letter of explanation, including the following information, must be enclosed:

- Model number of your filter
- Date of installation
- Name of installer
- Nature of problem
- Your address and telephone number

III. Harmsco allows for repair or replacement of warranted fresh water filter units during the ten (10) year period following initial installation at a prorated price. The replacement or repair price shall be prorated upon the following schedule.

YEAR OF SERVICE	REPLACEMENT PRICE
2nd	20% of then current list
3rd	30% of then current list
4th	40% of then current list
5th	50% of then current list
6th	60% of then current list
7th	70% of then current list
8th	80% of then current list
9th & 10th	90% of then current list

Specially coated filters for sea water (SW) use are warranted for one year only from the date of installation. The warranty for filters with special coatings is limited to the recoating of the defective parts, due to failure in materials or workmanship, for one year from date of installation.

Waterwarmer units and portable (BKP) units are warranted for one year.

IV. This warranty gives you specific legal rights, and you may also have other rights which vary from state to state.

V. There are no implied warranties for fitness nor merchantability which extend beyond the duration of this written warranty. Some states do not allow limitations on how long an implied warranty lasts, so the above limitation may not apply to you.

Harmsco, Inc. disclaims liability under this warranty for any damage to the filter unit caused by the use of improperly sized or improperly fitted filter cartridges.

Harmsco, Inc. disclaims liability under this warranty for any filter installed on any application other than a swimming pool.

----- FILL IN AND RETURN THIS CARD -----

**FILTER WARRANTY INFORMATION CARD**

Date of Installation \_\_\_\_\_

Purchased From (name and address of firm) \_\_\_\_\_

**Harmsco Betterfilter Model No. BF** \_\_\_\_\_ **Serial #:** \_\_\_\_\_

Size of Pool: \_\_\_\_\_ Gallons: \_\_\_\_\_

(check one box only:)  For Fresh Water  For Salt Water

Make of Pump \_\_\_\_\_

Horsepower of Pump \_\_\_\_\_

Your Name (owner) \_\_\_\_\_

Street \_\_\_\_\_

City \_\_\_\_\_ State \_\_\_\_\_ Zip \_\_\_\_\_

## SUGGESTED CHEMICAL OPERATIONAL PARAMETERS

The following information is provided by the National Spa and Pool Institute

CHLORINATION	Min	Ideal	Max.
Disinfectant Levels			
Free Chlorine, PPM	1.0	1.0-3.0	5.0
Combined Chlorine, PPM	None	None	0.2
<b>CHEMICAL VALUES</b>			
PH	7.2	7.4-7.6	7.8
Total Alkalinity, PPM	60	80-100	180
Total Dissolved Solids, PPM	300	1000-3000	3000
Hardness	150	200-400	500-1000
<b>REMEDIAL PRACTICES</b>			
Superchlorination	Monthly	When combined chlorine is 0.2 or more	Weekly

Note: Some high use spas and pools may need superchlorination three times a week or more.

### COMMENTS:

\* **Superchlorinate Regularly**

\* combined chlorine is eliminated by **Superchlorination**

NOTE: In order to maintain a proper chemical balance, you must have a good test kit and know how to use it.

To protect against electrolysis, all metal components of the water circulation and heating systems must be connected by wire to ground the entire system.

**Filter housings must be grounded**

**DO NOT STORE CHEMICALS NEAR FILTER HOUSING**



**HARMSCO, INC.** 7169 49th Terrace North, Riviera Beach, FL 33407 U.S.A.

(561) 848-9628 • (800) 327-3248 • Fax: (561) 845-2474 • email: sales@harmsco.com

HIM 2 08 1M

PLACE  
STAMP  
HERE

**HARMSCO, INC.**

7169 49th Terrace North  
Riviera Beach, FL 33407