

## WCR SERIES WATER COLLECTION & REMOVAL SYSTEMS

### APPLICATIONS

Collection of sewage, effluent, drainage or seepage water where concealed routing of plumbing and cables is desired

### FEATURES

- Pre-packaged 20" x 30" (51 cm x 76 cm) polyethylene basin with 4/10 hp sewage pump or 1 hp grinder
- Handles up to 2" (51 mm) solids
- Options of structural foam or steel covers
- Includes schedule 40 PVC discharge piping with pre-drilled air-bleed hole
- Designed with side outlets for discharge and electrical cords
- Includes 2" (51 mm) bulkhead fitting to easily route power cords out of basin
- Once installed, no digging required for system servicing
- Molded inlet hub, anti-torque stops, and 360° lifting handle
- Radial rib design for extra strength
- Integrated anti-floatation collar



### SERIES SPECIFICATIONS

Item No.	Model	Pump HP	Discharge	Check Valve	Cover	Volts	Weight lbs (Kg)	Pump Item No.	Pump Model
509081	WCR-9SP	4/10	2" 51 mm	2" Slip x Slip	Structural Foam	115	65 (29.5 Kg)	509412	9SC-CIA-RF
509082	WCR-9SS	4/10	2" 51 mm	2" Slip x Slip	Steel*	115	69 (31.3 Kg)	509412	9SC-CIA-RF
509817	WCR-16GP	1	2" 51 mm	2" Slip x Slip	Structural Foam	115	108 (49.0 Kg)	509810	16G-F151-20

\*Steel cover is not rated for foot or vehicle traffic

Basin Assemblies			
Item No.	Model No.	Basin Only Sub-Assy	Cover Only Sub-Assy
513245	BC2030CS-LG	113095	113002 (Structural Foam)
-	-	113095	113003 (Steel)

Note: Pump and switch assembly not included. If parts/sub-assemblies are ordered separately, the hardware is not necessarily included to assemble entire system.

### PUMP SPECIFICATIONS

HP	Volts	Hz	Amps	Watts	Gallons per minute (Liters per minute) @ Height				Shut-Off	PSI / Bar
					5'	10'	15'	20'		
4/10	115	60	8	870	100 (379)	80 (303)	60 (227)	-	20' (6.1 m)	8.7 / 0.60
1	115	60	12.5	-	51 (193)	49 (187)	47 (178)	44 (166)	53' (16.2 m)	22.9 / 1.58

Item No.	Model	HP	Volts	Discharge	Switch Type / Operation	On Level	Off Level	Cord	Weight lbs (Kg)
509412	9SC-CIA-RF	4/10	115	2"	Piggyback Mechanical Float	9" - 14" (22.86 cm - 35.56 cm)	2" - 6" (5 cm - 15.24 cm)	20' (6.1 m)	35.5 (16.1 Kg)
509810	16G-F151-20	1	115	2"	Piggyback Mechanical Float	13" - 18" (33.02 cm - 45.72 cm)	8" - 10" (20.3 cm - 25.4 cm)	20' (6.1 m)	78 (35.4 Kg)

### PUMP OPTIONS



9SC - 4/10 hp Sewage Ejector



16G - 1 hp Grinder Pump

# WCR SERIES - WATER COLLECTION & REMOVAL SYSTEMS

## ENGINEERING DATA

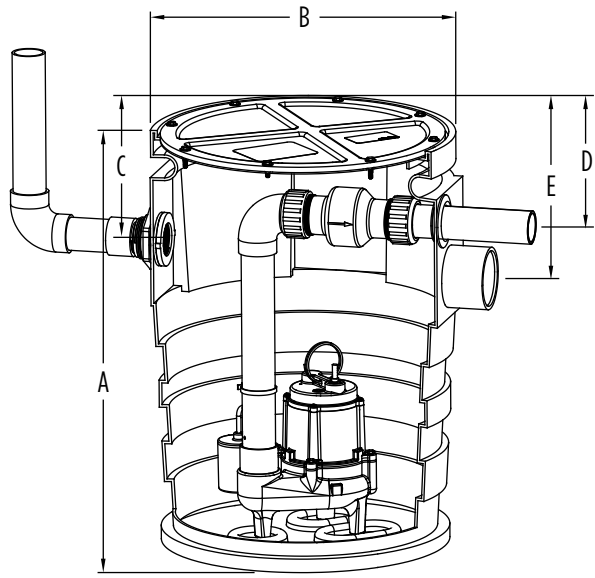

A	B	C	D	E
30" (76.2 cm)	22" (55.88 cm)	8.5" (21.59 cm)	5.5" (13.97 cm)	10" (25.4 cm)

### TYPICAL INSTALLATION

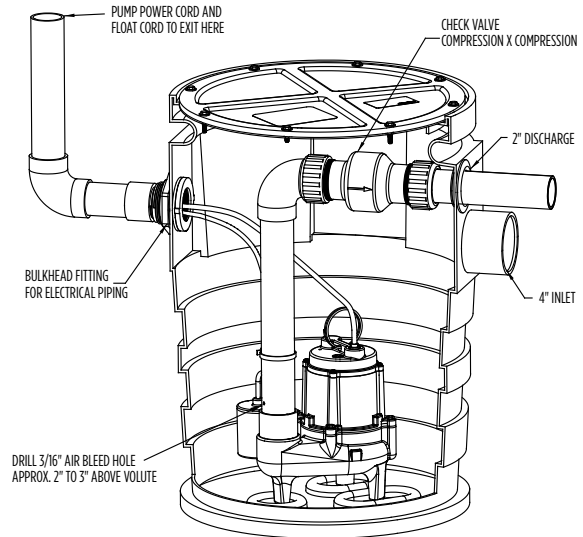

## PERFORMANCE DATA

### 9SC - 4/10 HP SEWAGE EJECTOR

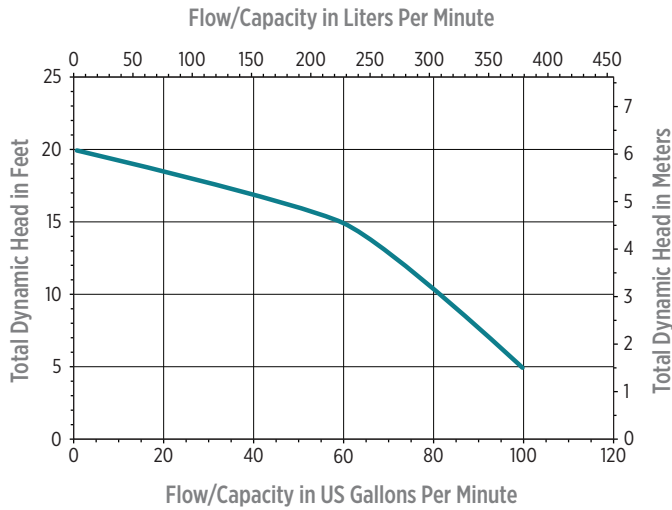

### 16G - 1 HP GRINDER PUMP

