

5 SERIES - 1/6 HP

APPLICATIONS

The 5-Series is one of the most compact utility pumps on the market. Ideal for light commercial and multi-purpose residential applications where water removal, transfer, or circulation is required.

FEATURES

- Corrosion- and rust-resistant, epoxy-coated cast aluminum pump housing gives strength and high heat dissipation for both consumer and professional use
- Rated for continuous duty which allows for a wide range of applications and uses
- Compact design with manual version weighing in just under seven pounds makes this pump truly portable
- 1/6 hp energy efficient and oil free PSC motor is environmentally friendly and delivers 1500 gph maximum capacity
- FKM triple-lip seal
- Upper and lower ball bearings for long life
- 1" FNPT discharge (includes garden hose adapter for quick plug and play)
- Removable inlet screen allows for easy cleaning without tools
- In manual operation, pumps down to 1/8" (3.2 mm) with screen, and down to 1/16" (1.6 mm) without screen to reduce overall water removal clean up time and effort
- Multiple switch options for automatic operation gives application flexibility
- Multiple power cord lengths available
- Fully certified for continuous duty liquid temperature rating of up to 86 °F (30 °C)
- cULus on items 505723, 505712, 505714, 505715, 505717



5-MSP

5-ASP



SERIES SPECIFICATIONS

Volts	Hz	Amps FLA	Watts	Gallons per hour (Liters per hour) @ Height					Shut-Off	PSI
				1'	3'	5'	10'	20'		
115	60	2.0	220	1500 5678	1464 5542	1395 5281	1191 4508	528 1999	26' (7.9 m)	11.43
230	60	1.0	220	1500 5678	1464 5542	1395 5281	1191 4508	528 1999	26' (7.9 m)	11.43

Item No.	Model	HP	Volts	Switch Type / Operation	On Level	Off Level	Cord	Weight lbs (Kg)
505715	5-ASP	1/6	115	Piggyback Diaphragm (Standard Version)	6" - 9" 15.2 cm - 22.9 cm	1" - 4" 2.5 cm - 10.2 cm	10' (3 m)	7.5 (3.4 kg)
505717	5-ASP-LL	1/6	115	Piggyback Diaphragm (Low Level Version)	2" - 3" 5.1 cm - 7.6 cm	1/2" - 1-1/2" 1.3 cm - 3.8 cm	18' (5.5 m)	8.0 (3.6 kg)
505711	5-MSP Hydroponics	1/6	115	Manual	-	-	10' (3 m)	7.0 (3.2 kg)
505723	5-MSP	1/6	115	Manual	-	-	10' (3 m)	7.0 (3.2 kg)
505712	5-MSP	1/6	115	Manual	-	-	25' (7.6 m)	7.4 (3.4 kg)
505714	5-MSP	1/6	230	Manual	-	-	12' (3.7 m)	7.0 (3.2 kg)
505721	5-MSP	1/6	127	Manual	-	-	18' (5.5 m)	7.2 (3.3 kg)

5 SERIES - 1/6 HP

ENGINEERING DATA

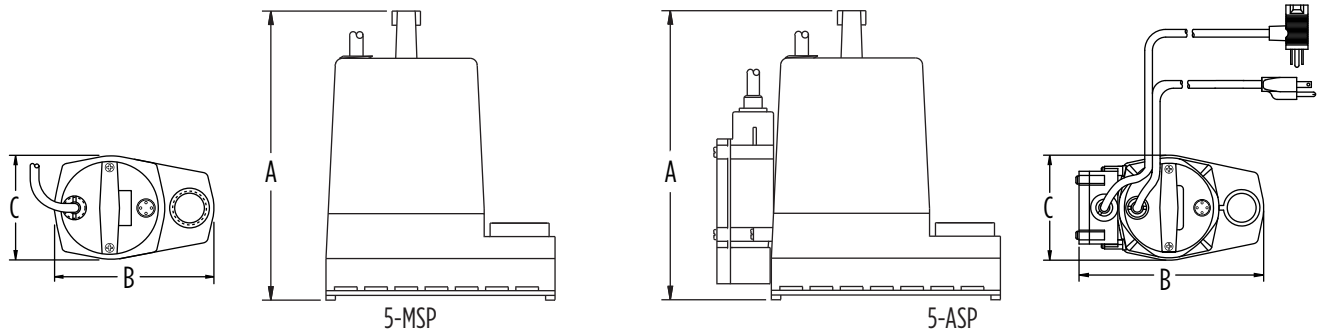

Model	A	B	C
5-MSP	8.07" (20.50 cm)	6.10" (15.50 cm)	4.29" (10.90 cm)
5-ASP	8.07" (20.50 cm)	7.75" (19.69 cm)	4.29" (10.90 cm)v

PERFORMANCE DATA

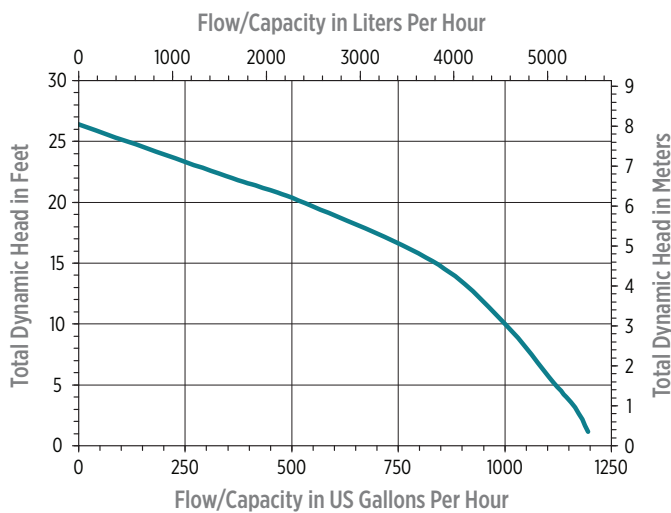

CONSTRUCTION

Motor Housing	Epoxy-coated cast aluminum
Impeller Material	Nylon
Impeller Type	Semi-open
Volute	Nylon
Motor Shaft	Stainless steel
Shaft Seal	Fluoroelastomer (FKM)
Fasteners	Stainless steel
Bearings	Upper and lower ball bearing
Power Cord	SJTW
RPM	3450
Motor Type	PSC