

9EC SERIES - 4/10 HP

APPLICATIONS

Effluent wastewater removal, dewatering, water transfer

FEATURES

- Permanent Split Capacitor (PSC)
- Designed for continuous duty
- Energy-saving low amp draw
- 1-1/2" FNPT (38 mm) discharge
- Handles solids up to 3/4" (19 mm) diameter
- Multiple switch options for automatic operation
- 140 °F (60 °C) liquid temperature rating
- cCSAus listed



SERIES SPECIFICATIONS

Model	HP	Volts	HZ	Amps		Watts	Max. Water Temp.	Gallons per minute (Liters per Minute) @ Height				Shut-Off	PSI / Bar
				FLA	Start			5'	10'	20'	30'		
9EC	4/10	115	60	7.5	14.5	800	140 °F / 60 °C	70 (265)	65 (246)	50 (189)	30 (114)	40' (12.2 m)	17.3 / 1.19
	4/10	208-230	50/60	4/4	10/10	820/900	140 °F / 60 °C	70 (265)	65 (246)	50 (189)	30 (114)	40' (12.2 m)	17.3 / 1.19

Item No.	Model	HP	Volts	Switch Type / Operation	On Level	Off Level	Cord	Weight lbs (Kg)
509804	9EC-CIA-SFS	4/10	115	Integral Float Switch	7" - 10" (18 cm - 25 cm)	2" - 5" (5 cm - 13 cm)	30' (9.1 m)	28.5 (12.93 Kg)
509801	9EC-CIA-RF	4/10	115	Piggyback Float Switch	12" - 15" (30 cm - 38 cm)	6" - 9" (15 cm - 23 cm)	20' (6.1 m)	27.5 (12.47 Kg)
509802	9EC-CIA-RF	4/10	115	Piggyback Float Switch	12" - 15" (30 cm - 38 cm)	6" - 9" (15 cm - 23 cm)	30' (9.1 m)	28.5 (12.93 Kg)
509806	9EC-CIM	4/10	115	Manual	-	-	10' (3.0 m)	27.5 (12.47 Kg)
509805	9EC-CIM	4/10	115	Manual	-	-	20' (6.1 m)	27.5 (12.47 Kg)
509808	9EC-CIM	4/10	115	Manual	-	-	30' (9.1 m)	28.5 (12.93 Kg)
509803	9EC-CIA-RF	4/10	208-230	Piggyback Float Switch	12" - 15" (30 cm - 38 cm)	6" - 9" (15 cm - 23 cm)	20' (6.1 m)	27.5 (12.47 Kg)
509807	9EC-CIM	4/10	208-230	Manual	-	-	20' (6.1 m)	27.5 (12.47 Kg)

EFFLUENT PUMPS

9EC SERIES - 4/10 HP

ENGINEERING DATA

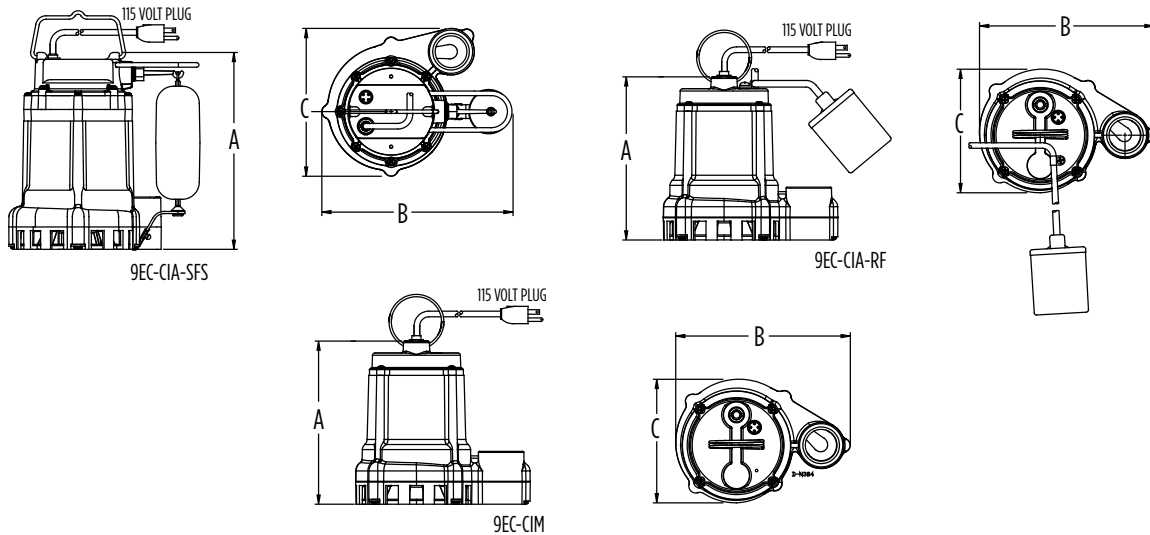

Model	A	B	C
9EC-CIA-SFS	11.8" (30 cm)	10.7" (27.1 cm)	8.4" (21.4 cm)
9EC-CIA-RF	11.0" (28 cm)	8.9" (22.6 cm)	8.4" (21.4 cm)
9EC-CIM	11.0" (28 cm)	8.9" (22.6 cm)	8.4" (21.4 cm)

PERFORMANCE DATA

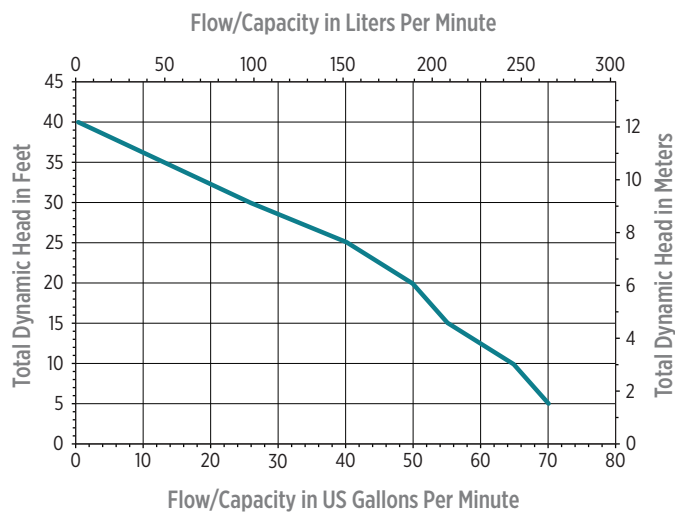

CONSTRUCTION

Cover	Epoxy-coated cast iron/ *Thermoplastic
Motor Housing	Epoxy-coated cast iron
Impeller Material	Thermoplastic elastomer
Impeller Type	Non-clog
Volute	Epoxy-coated cast iron
Motor Shaft	Steel
Mechanical Shaft Seal	Nitrile with carbon and ceramic faces
Fasteners	Stainless steel
Bearings	Upper and lower ball bearings
Power Cord	SJTW **SJTOW

* On SFS models

** On 30' 9EC-CIA-RF and 9EC-CIM models

