

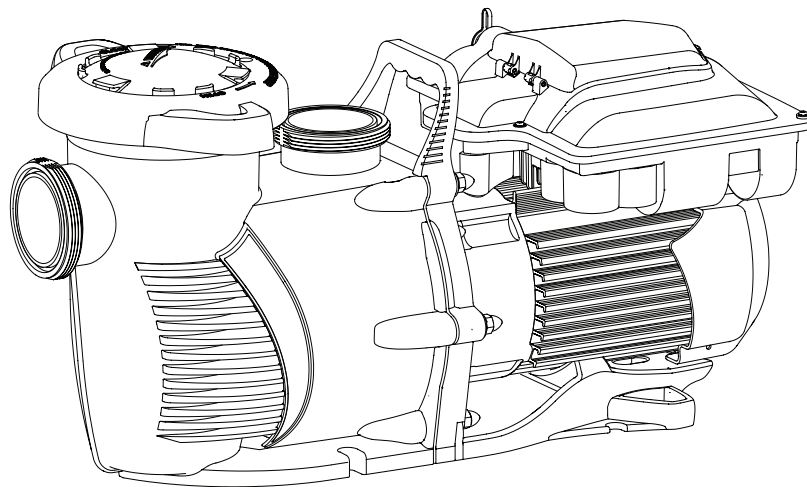

# WHISPERFLOXF<sup>®</sup> VS AND MAX-E-PROXF<sup>®</sup> VS

COMMERCIAL VARIABLE SPEED PUMP



## INSTALLATION AND USER'S GUIDE

IMPORTANT SAFETY INSTRUCTIONS  
*READ AND FOLLOW ALL INSTRUCTIONS*  
SAVE THESE INSTRUCTIONS

# IMPORTANT SAFETY INSTRUCTIONS



## IMPORTANT NOTICE

This guide provides installation and operation instructions for this pump. Consult Pentair with any questions regarding this equipment.

**Attention Installer:** This guide contains important information about the installation, operation and safe use of this product. This information should be given to the owner and/or operator of this equipment after installation or left on or near the pump.

**Attention User:** This manual contains important information that will help you in operating and maintaining this product. Please retain it for future reference.

### READ AND FOLLOW ALL INSTRUCTIONS SAVE THESE INSTRUCTIONS



This is the safety alert symbol. When you see this symbol on your system or in this manual, look for one of the following signal words and be alert to the potential for personal injury.

#### **DANGER**

Warns about hazards that can cause death, serious personal injury, or major property damage if ignored.

#### **WARNING**

Warns about hazards that may cause death, serious personal injury, or major property damage if ignored.

#### **CAUTION**

Warns about hazards that may or can cause minor personal injury or property damage if ignored.

#### NOTE

Indicates special instructions not related to hazards.

Carefully read and follow all safety instructions in this manual and on equipment. Keep safety labels in good condition; replace if missing or damaged.

When installing and using this electrical equipment, basic safety precautions should always be followed, include the following:

#### **DANGER**

FAILURE TO FOLLOW ALL INSTRUCTIONS AND WARNINGS CAN RESULT IN SERIOUS BODILY INJURY OR DEATH. **THIS PUMP SHOULD BE INSTALLED AND SERVICED ONLY BY A QUALIFIED POOL SERVICE PROFESSIONAL. INSTALLERS, POOL OPERATORS AND OWNERS MUST READ THESE WARNINGS AND ALL INSTRUCTIONS IN THE OWNER'S MANUAL BEFORE USING THIS PUMP. THESE WARNINGS AND THE OWNER'S MANUAL MUST BE LEFT WITH THE POOL OWNER.**

#### **WARNING**

Do not permit children to use this product.

#### **WARNING**

**RISK OF ELECTRICAL SHOCK.** Connect only to a branch circuit protected by a ground-fault circuit-interrupter (GFCI). Contact a qualified electrician if you cannot verify that the circuit is protected by a GFCI.

#### **WARNING**

This unit must be connected only to a supply circuit that is protected by a ground-fault circuit-interrupter (GFCI). Such a GFCI should be provided by the installer and should be tested on a routine basis. To test the GFCI, push the test button. The GFCI should interrupt power. Push the reset button. Power should be restored. If the GFCI fails to operate in this manner, the GFCI is defective. If the GFCI interrupts power to the pump without the test button being pushed, a ground current is flowing, indicating the possibility of an electric shock. Do not use this pump. Disconnect the pump and have the problem corrected by a qualified service representative before using.

#### **CAUTION**

This pump is for use with permanent swimming pools and may also be used with hot tubs and spas if so marked. Do not use with storable pools. A permanently-installed pool is constructed in or on the ground or in a building such that it cannot be readily disassembled for storage. A storable pool is constructed so that it is capable of being readily disassembled for storage and reassembled to its original integrity.

### General Warnings

- Never open the inside of the drive motor enclosure. There is a capacitor bank that holds a 230 VAC charge even when there is no power to the unit.
- The pump is not submersible.
- The pump is capable of high flow rates; use caution when installing and programming to limit pumps performance potential with old or questionable equipment.
- Code requirements for electrical connection differ from country to country, state to state, as well as local municipalities. Install equipment in accordance with the National Electrical Code and all applicable local codes and ordinances.
- Before servicing the pump; switch OFF power to the pump by disconnecting the main circuit to the pump.
- This appliance is not intended for use by persons (including children) of reduced physical, sensory or mental capabilities, or lack of experience and knowledge, unless they have been given supervision or instruction concerning the use of the appliance by a person responsible for their safety.

#### **DANGER**

**SUCTION ENTRAPMENT HAZARD: STAY OFF THE MAIN DRAIN AND AWAY FROM ALL SUCTION OUTLETS! THIS PUMP IS NOT EQUIPPED WITH SAFETY VACUUM RELEASE SYSTEM (SVRS) PROTECTION AND DOES NOT PROTECT AGAINST BODY OR LIMB ENTRAPMENTS, DISEMBOWELMENTS (WHEN A PERSON SITS ON A BROKEN OR UNCOVERED POOL DRAIN) OR HAIR ENTANGLEMENTS.**



THIS PUMP PRODUCES HIGH LEVELS OF SUCTION AND CREATES A STRONG VACUUM AT THE MAIN DRAIN AT THE BOTTOM OF THE BODY OF WATER. THIS SUCTION IS SO STRONG THAT IT CAN TRAP ADULTS OR CHILDREN UNDER WATER IF THEY COME IN CLOSE PROXIMITY TO A DRAIN OR A LOOSE OR BROKEN DRAIN COVER OR GRATE.

THE USE OF UNAPPROVED COVERS OR ALLOWING USE OF THE POOL OR SPA WHEN COVERS ARE MISSING, CRACKED OR BROKEN CAN RESULT IN BODY OR LIMB ENTRAPMENT, HAIR ENTANGLEMENT, BODY ENTRAPMENT, EVISCERATION AND/OR DEATH.

**The suction at a drain or outlet can cause:**

**Limb Entrapment:** When a limb is sucked or inserted into an opening resulting in a mechanical bind or swelling. This hazard is present when a drain cover is missing, broken, loose, cracked or not properly secured.

**Hair Entanglement:** When the hair tangles or knots in the drain cover, trapping the swimmer underwater. This hazard is present when the flow rating of the cover is too small for the pump or pumps.

**Body Entrapment:** When a portion of the body is held against the drain cover trapping the swimmer underwater. This hazard is present when the drain cover is missing, broken or the cover flow rating is not high enough for the pump or pumps.

**Evisceration/Disembowelment:** When a person sits on an open pool (particularly a child wading pool) or spa outlet and suction is applied directly to the intestines, causing severe intestinal damage. This hazard is present when the drain cover is missing, loose, cracked, or not properly secured.

**Mechanical Entrapment:** When jewelry, swimsuit, hair decorations, finger, toe or knuckle is caught in an opening of an outlet or drain cover. This hazard is present when the drain cover is missing, broken, loose, cracked, or not properly secured.

**NOTE: ALL SUCTION PLUMBING MUST BE INSTALLED IN ACCORDANCE WITH THE LATEST NATIONAL AND LOCAL CODES, STANDARDS AND GUIDELINES.**

# IMPORTANT SAFETY INSTRUCTIONS

## **⚠ WARNING** TO MINIMIZE THE RISK OF INJURY DUE TO SUCTION ENTRAPMENT HAZARD:

- A properly installed and secured ANSI/ASME A112.19.8 approved anti-entrapment suction cover must be used for each drain.
- Each suction cover must be installed at least three (3') feet apart, as measured from the nearest point to nearest point.
- Regularly inspect all covers for cracks, damage and advanced weathering.
- If a cover becomes loose, cracked, damaged, broken or is missing, replace with an appropriate certified cover.
- Replace drain covers as necessary. Drain covers deteriorate over time due to exposure to sunlight and weather.
- Avoid getting hair, limbs or body in close proximity to any suction cover, pool drain or outlet.
- Disable suction outlets or reconfigure into return inlets.

**⚠ WARNING** The pump can produce high levels of suction within the suction side of the plumbing system. These high levels of suction can pose a risk if a person comes within the close proximity of the suction openings. A person can be seriously injured by this high level of vacuum or may become trapped and drown. It is absolutely critical that the suction plumbing be installed in accordance with the latest national and local codes for swimming pools.

**⚠ WARNING** A clearly labeled emergency shut-off switch for the pump must be in an easily accessible, obvious place. Make sure users know where it is and how to use it in case of emergency.

**The Virginia Graeme Baker (VGB) Pool and Spa Safety Act** creates new requirements for owners and operators of commercial swimming pools and spas.

Commercial pools or spas constructed on or after December 19, 2008, shall utilize:

(A) A multiple main drain system without isolation capability with suction outlet covers that meet ASME/ANSI A112.19.8a Suction Fittings for Use in Swimming Pools, Wading Pools, Spas, and Hot Tubs and either:

(i) A safety vacuum release system (SVRS) meeting ASME/ANSI A112.19.17 Manufactured Safety Vacuum Release systems (SVRS) for Residential and Commercial Swimming Pool, Spa, Hot Tub, and Wading Pool Suction Systems and/or ASTM F2387 Standard Specification for Manufactured Safety Vacuum Release Systems (SVRS) for Swimming pools, Spas and Hot Tubs or

(ii) A properly designed and tested suction-limiting vent system or

(iii) An automatic pump shut-off system.

Commercial pools and spas constructed prior to December 19, 2008, with a single submerged suction outlet shall use a suction outlet cover that meets ASME/ANSI A112.19.8a and either:

(A) A SVRS meeting ASME/ANSI A112.19.17 and/or ASTM F2387, or

(B) A properly designed and tested suction-limiting vent system, or

(C) An automatic pump shut-off system, or

(D) Disabled submerged outlets, or

(E) Suction outlets shall be reconfigured into return inlets.

## **⚠ CAUTION** For Installation of Electrical Controls at Equipment Pad (ON/OFF Switches, Timers and Automation Load Center)



Install all electrical controls at equipment pad, such as on/off switches, timers, and control systems, etc. to allow the operation (startup, shut-down, or servicing) of any pump or filter so the user does not place any portion of his/her body over or near the pump strainer lid, filter lid or valve closures. This installation should allow the user enough space to stand clear of the filter and pump during system start-up, shut down or servicing of the system filter.

## **⚠ DANGER** HAZARDOUS PRESSURE: STAND CLEAR OF PUMP AND FILTER DURING START UP.



Circulation systems operate under high pressure. When any part of the circulating system (i.e. locking ring, pump, filter, valves, etc.) is serviced, air can enter the system and become pressurized. Pressurized air can cause the pump housing cover, filter lid, and valves to violently separate which can result in severe personal injury or death. Filter tank lid and strainer cover must be properly secured to prevent violent separation. Stand clear of all circulation system equipment when turning on or starting up pump. Before servicing equipment, make note of the filter pressure. Be sure that all controls are set to ensure the system cannot inadvertently start during service. Turn off all power to the pump. **IMPORTANT: Place filter manual air relief valve in the open position and wait for all pressure in the system to be relieved.**

Before starting the system, fully open the manual air relief valve and place all system valves in the "open" position to allow water to flow freely from the tank and back to the tank. Stand clear of all equipment and start the pump.

**IMPORTANT: Do not close filter manual air relief valve until all pressure has been discharged from the valve and a steady stream of water appears.** Observe filter pressure gauge and be sure it is not higher than the pre-service condition.

### General Installation Information

- All work must be performed by a qualified service professional, and must conform to all national, state, and local codes.
- Install to provide drainage of compartment for electrical components.
- These instructions contain information for a variety of pump models and therefore some instructions may not apply to a specific model. All models are intended for use in swimming pool applications. The pump will function correctly only if it is properly sized to the specific application and properly installed.

**⚠ WARNING** Pumps improperly sized or installed or used in applications other than for which the pump was intended can result in severe personal injury or death. These risks may include but not be limited to electric shock, fire, flooding, suction entrapment or severe injury or property damage caused by a structural failure of the pump or other system component.

**Pumps and replacement motors that are single speed and one (1) Total HP or greater cannot be sold, offered for sale, or installed in a residential pool for filtration use in California, Title 20 CCR sections 1601-1609.**

## CUSTOMER SERVICE / TECHNICAL SUPPORT

If you have questions about ordering Pentair replacement parts, and pool products, please contact:

### Customer Service and Technical Support, USA

(8 A.M. to 4:30 P.M. — Eastern/Pacific Times)

Phone: (800) 831-7133

Fax: (800) 284-4151

### Web site

Visit [www.pentair.com](http://www.pentair.com) for information about our products.\*

### Sanford, North Carolina (8 A.M. to 4:30 P.M. ET)

Phone: (919) 566-8000

Fax: (919) 566-8920

### Moorpark, California (8 A.M. to 4:30 P.M. PT)

Phone: (805) 553-5000 (Ext. 5591)

Fax: (805) 553-5515

## TABLE OF CONTENTS

<b>Important Safety Instructions</b> .....	<b>i</b>	<b>Maintenance</b> .....	<b>16</b>
<b>Introduction</b> .....	<b>1</b>	Cleaning the Pump Strainer Basket	16
Motor Features	1	Winterizing	16
Drive Assembly and Keypad	1	Motor and Drive Care	17
Drive Features	1	Pump Disassembly	17
External Control	1	Shaft Seal Replacement	18
<b>Using the Drive Keypad</b> .....	<b>2</b>	Pump Reassembly	18
<b>Installation</b> .....	<b>3</b>	Replacing the Drive Assembly	19
Location	3	<b>Troubleshooting</b> .....	<b>20</b>
Piping	3	Faults and Alarms	22
Fittings and Valves	3	<b>Replacement Parts</b> .....	<b>23</b>
Electrical Requirements	3	<b>Technical Data</b> .....	<b>24</b>
Electrical Installation	4	Performance Curves	24
Wiring, Grounding and Bonding	4	Pump Dimensions	24
External Control via RS-485	5	Electrical Specifications	24
External Control via Digital Inputs	6	Mechanical Specifications	24
Using the Pump's Output Signal	6		
Using an External Input Signal	7		
External Control Only Mode	7		
<b>Operation</b> .....	<b>8</b>		
Setting the Clock and Pump Address	8		
Using the Default Schedule	8		
Programming Custom Schedules	8		
Program Priorities (Non-External Control)	9		
Priming the Pump	10		
Priming Adjustment	11		
Operating the Pump While Running	12		
Programming Quick Clean	12		
Keypad Lockout	13		
Factory Reset	13		
Operating the Pump in Flow Mode	14		
Flow Mode Setup and Configuration	14		
Adjusting Flow Setting	15		

\* Translated versions of this manual are available online at / La versión en español de este manual del producto, se puede encontrar en línea a / La versión française de ce manuel est disponible à :

<https://www.pentair.com/content/pentair/en/products/pool-spa-equipment/pool-pumps/whisperflox-variable-speed-pump.html>

<https://www.pentair.com/content/pentair/en/products/pool-spa-equipment/pool-pumps/max-e-proxf-variable-speed-pump.html>

# INTRODUCTION

The WhisperFloXF® VS or Max-E-ProXF® VS Commercial Variable Speed Pump can be programmed to run at specific speeds and time intervals for maximum operating efficiency and energy conservation for a variety of inground pools.

- The pump can operate at any speed between 300 RPM to 3450 RPM for different applications, with four preset speeds of 1720, 2500, 3000 and 3450 (Quick Clean).
- Alarm LED and error messages warn the user against under and over voltage, high temperature and over current, etc.
- Communicates with most Pentair automation systems via the Digital Input Wiring Kit (P/N 353129Z - Almond) or RS-485 Automation Wiring Kit (P/N 356324Z - Black).
- Adjustable priming speed for easy start-up
- Compatible with most cleaning systems, filters, and jet action spas
- WEF 5.0 THP 5.0

## Motor Features

- Superior speed control for commercial applications
- Operates at lower temperatures due to high efficiency
- Designed to withstand outdoor environment
- 56 Square Flange Totally Enclosed Fan Cooled (TEFC) Motor
- Low noise

## Drive Assembly and Keypad

The pump features a variable frequency drive capable of controlling the motor speed according to programmed settings. This provides flexibility in meeting your filtration system's specific needs.

The pump is intended to run at the lowest speeds needed to maintain a sanitary environment and, at the same time, minimize energy consumption. Factors such as pool size, the presence of additional water features, type of chemicals used to maintain sanitary conditions, and local environmental factors will impact optimal programming to maximize energy conservation. Determining the optimal settings and programming for your pool may require some trial-and-error.

## Drive Features

- Active Power Factor Correction
- High Drive Operational Efficiency
- Flow Control Capable when Paired with a 4-20mA Flowmeter (Pentair P/N 97014-4203KIT).
- Versatile Power Input:
  - Single-Phase, 208-230/277-460V, 20-21/17-11A
  - 3-Phase, 208-460V, 13-6A

## External Control

The pump can be externally controlled via digital inputs using the Digital Input Wiring Kit (P/N 353129Z - Almond) the RS-485 Automation Wiring Kit (P/N 356324Z - Black). See *External Control via Digital Inputs*, page 6 or *External Control via RS-485*, page 5.

When connected to external controls, the pump will prioritize commands as follows:

*RS-485 > Digital Inputs > Drive Programmed Schedules*

Refer to your control system manual for further details on how to connect and program your pump with your control system.

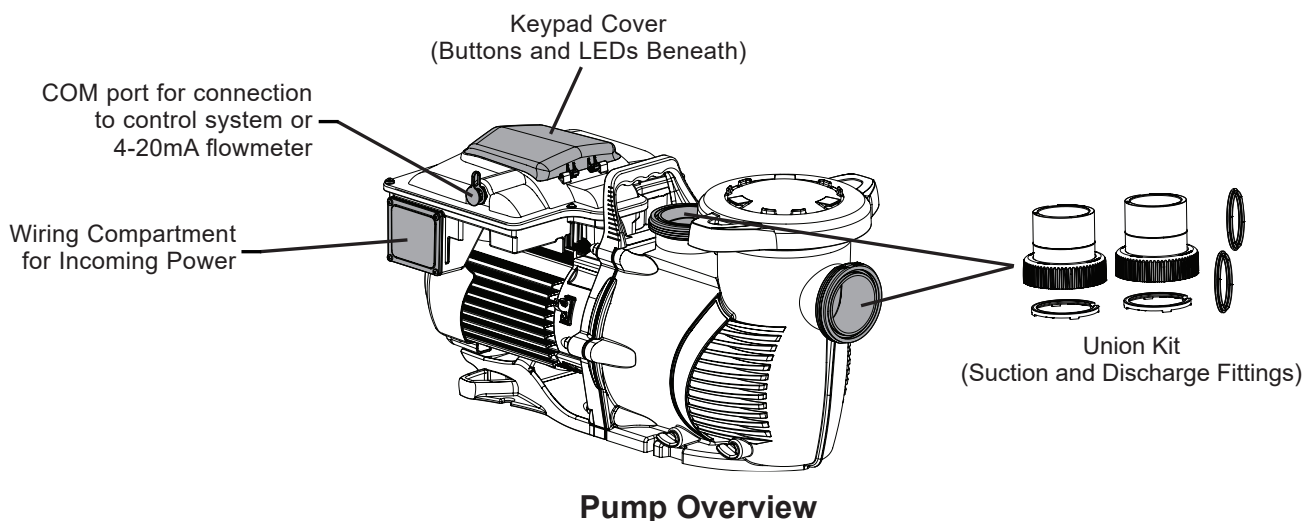

## USING THE DRIVE KEYPAD

Before operating the pump for the first time, the pump's internal clock and operational schedules must be programmed. Please refer to *Setting the Clock and Pump Address* and *Programming Custom Schedules*, page 8, for instructions regarding the programming of this pump for scheduled operation.

This pump is capable of maintaining either constant speeds or constant flows. The default setting is Speed Control. For information on configuring the pump for Flow Control via 4-20mA flowmeter, refer to *Operating the Pump in Flow Mode*, page 14.

The pump can be programmed and controlled from the drive keypad. Pump features and settings are also accessed using this keypad.

**Note:** Always close the keypad cover after use. This will prevent damage to the keypad and other drive components.

**CAUTION** Only press keypad buttons with your fingers. Using screwdrivers, pens or other tools to program the pump will damage the keypad.

**WARNING** If power is connected to the pump motor, pressing any of the following buttons referred to in this section could result in the motor starting. Failure to recognize this could result in personal injury or damage to equipment.

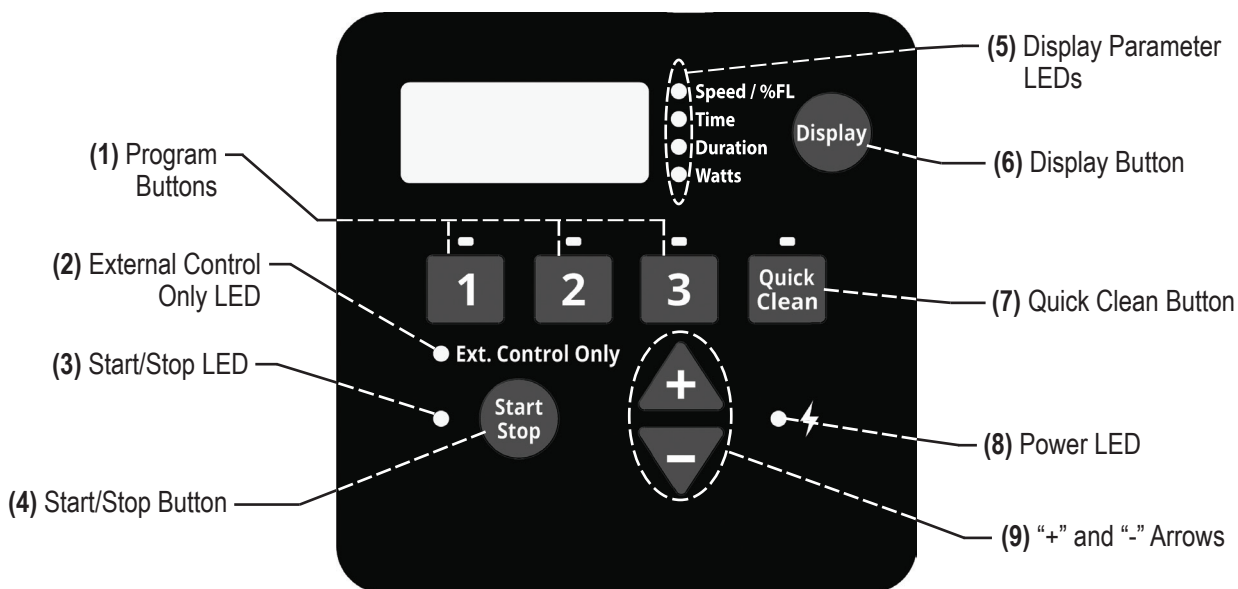

1. **Program Buttons** - Used to select a desired program. When the LED above a Program Button is illuminated that program has been selected or is currently running. A blinking LED indicates that an External Control has activated that program.
2. **External Control Only LED** - Indicates whether the pump is in External Control mode. When LED is illuminated the drive-programmed schedules are disabled and only commands from digital inputs will be acted upon.
3. **Start/Stop LED** - Indicates whether the pump is in a "Start State". When illuminated the pump can be started at any time by external controls, drive-programmed schedules or manual inputs. When the pump is stopped and the LED is not illuminated, the pump is unable to run from any type of input. Functionality may vary based on other active features such as external control only mode or keypad lockout.
4. **Start/Stop Button** - Used to start and stop the pump. When the pump is stopped and the Start/Stop LED is not illuminated, the pump is unable to run from any input.
5. **Display Parameter LEDs** - When illuminated, LED indicates the information being displayed on screen. A blinking LED indicates that the parameter is currently being edited.
6. **Display Button** - Used to toggle between the different available display modes. This button is also used to set the clock, screen brightness and pump address.
7. **Quick Clean Button** - Used to run the speed and duration programmed for Quick Clean. When the LED above the Quick Clean Button is illuminated a Quick Clean cycle is active.
8. **Power LED** - When illuminated, LED indicates that there is live power being supplied to the pump.
9. **"+" and "-" Arrows** - Used to make adjustments to the pump settings. The "+" arrow increases a value, while "-" decreases a value. Pressing and holding either arrow button will increase or decrease incremental changes faster.

# INSTALLATION

Only a qualified plumbing professional should install the WhisperFloXF® VS and Max-E-ProXF® VS Commercial Variable Speed Pumps. Refer to “*Important Safety Instructions*” on pages i - ii for additional installation and safety information.

## Location

**Note:** Do not install this pump within an outer enclosure or beneath the skirt of a hot tub or spa unless marked accordingly.

**Note:** Ensure the pump is secured to the equipment pad.

### ENSURE THE INSTALL LOCATION MEETS THE FOLLOWING REQUIREMENTS:

1. Install the pump as close to the pool or spa as possible. To reduce friction loss and improve efficiency, use short, direct suction and return piping.
2. Install a minimum of 5 ft. (1.5 m) from the inside wall of the pool and spa. Canadian installations require a minimum of 9.8 ft. (3 m) from the inside wall of the pool.
3. Install the pump a minimum of 3 ft. (0.9 m) from a heater outlet.
4. Do not install the pump more than 10 ft. (3.1 m) above the water level.
5. Install the pump in a well ventilated location protected from excess moisture (i.e. rain gutter downspouts, sprinklers, etc.).
6. Install the pump with a rear clearance of at least 3 inches (7.6 cm) so that the motor can be removed easily for maintenance and repair. See **Figure 1**.

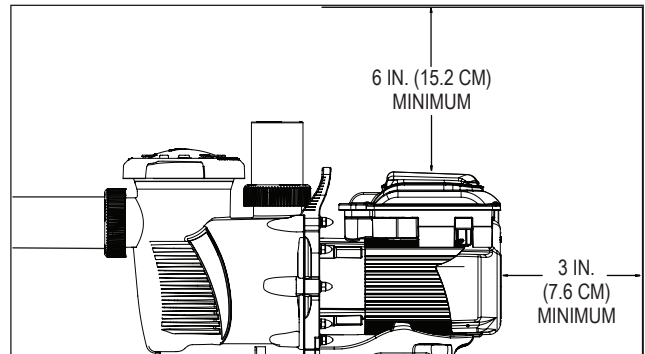

**Figure 1**

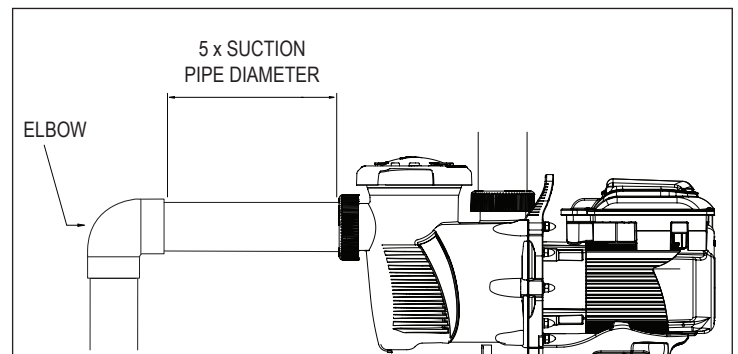

**Figure 2**

## Piping

1. For improved pool plumbing, it is recommended to use a larger pipe size.
2. Piping on the suction side of the pump should be the same or larger than the return line diameter.
3. Plumbing on the suction side of the pump should be as short as possible.
4. For most installations Pentair recommends installing a valve on both the pump suction and return lines so that the pump can be isolated during routine maintenance. However, we also recommend that a valve, elbow or tee installed in the suction line should be no closer to the front of the pump than five times the suction line diameter. See **Figure 2**.

**Example:** A 2.5 inch pipe requires a 12.5 inch (31.8 cm) straight run in front of the suction port. This will help the pump prime faster and last longer.

**Note:** DO NOT install 90° elbows directly into the suction or discharge ports.

## Fittings and Valves

1. Do not install 90° elbows directly into suction port.
2. Flooded suction systems should have gate valves installed on suction and discharge pipes for maintenance, however, the suction gate valve should be no closer than five times the suction pipe diameter as described in this section.
3. Use a check valve in the discharge line when using this pump for any application where there is significant height to the plumbing after the pump.
4. Be sure to install check valves when plumbing in parallel with another pump. This helps prevent reverse rotation of the impeller and motor.

## Electrical Requirements

- Install all equipment in accordance with the National Electrical code and all applicable local codes and ordinances.
- A means for disconnection must be incorporated in the fixed wiring in accordance with the wiring rules.

## Electrical Installation

### ⚠ WARNING



**RISK OF ELECTRICAL SHOCK OR ELECTROCUTION.** This pump must be installed by a licensed or certified electrician or a qualified service professional in accordance with the National Electrical Code and all applicable local codes and ordinances. Improper installation will create an electrical hazard which could result in death or serious injury to users, installers, or others due to electrical shock, and may also cause damage to property.

**Always disconnect power to the pump at the circuit breaker before servicing the pump. Failure to do so could result in death or serious injury to service people, users or others due to electric shock.**

Read all servicing instructions before working on the pump.

**Note:** ALWAYS reinstall the cover onto the field wiring compartment when leaving the pump unsupervised. This will prevent foreign matter (rainwater, dust, etc.) from accumulating inside the compartment.

**Note:** When connecting the pump to an automation system, continuous power must be supplied to the pump by connecting it directly to the circuit breaker. When using an automation system, be sure that no other lights or appliances are on the same circuit.

## Wiring

### ⚠ WARNING

**DO NOT** install this pump in conjunction with a motor starter. Using a motor starter with this pump can cause low voltage alarms and may cause permanent drive damage.

1. Be sure all electrical breakers and switches are turned off before wiring motor.

### ⚠ WARNING

**STORED CHARGE** - Wait at least 60 seconds before servicing.

2. Be sure that the supply voltage meets the requirements listed on the motor nameplate. If these requirements are not met, permanent motor damage may occur.
3. For wiring sizes and general guidelines for proper electrical installation, please follow the specifications defined in the National Electric Code and any local codes as required.
4. Use a strain relief and be sure all electrical connections are clean and tight.
5. Cut the wires to the appropriate length so they do not overlap or touch when connected.
6. Wire the pump according to instructions given on the inside of the field wiring cover, then secure the field wiring cover with the four corner screws.

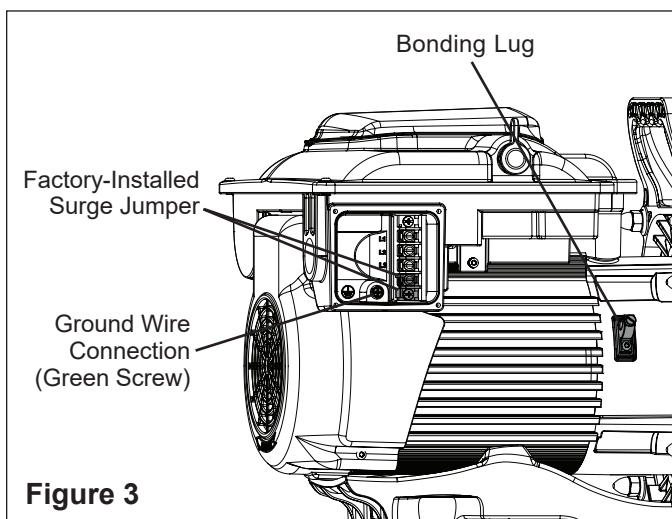

**Figure 3**

## Grounding

1. Permanently ground the motor using the green ground screw (**Figure 3**). Use the correct wire size and type specified by National Electrical Code. Be sure the ground wire is connected to an electrical service ground.
2. The pump should be permanently connected to either a circuit breaker, 2-pole timer or 2-pole relay.

**Note:** If AC power is supplied by a GFCI circuit breaker, the pump should be wired on its own independent circuit **unless the pump is operated in tandem with a Pentair salt chlorine generator.**

3. A surge jumper has been factory-installed between the two bottom screw terminals in the wiring compartment. Ensure this surge jumper is in place before wiring the pump. See **Figure 3**.

### ⚠ WARNING

This surge jumper grounds all drive components and will protect them from repeated voltage surges. If surge jumper is not installed damage to the pump drive may occur.

## Bonding

1. Bond the motor to the structure in accordance with the National Electrical Code. Use a solid copper bonding conductor not smaller than 8 AWG. For Canadian installations, a 6 AWG or larger solid copper bonding conductor is required. Run a wire from the external bonding screw or lug to the bonding structure.
2. Connect the wire from the accessible bonding lug on the motor to all metal parts of the swimming pool, spa, or hot tub structure and to all electrical equipment, metal conduit, and metal piping within 5 ft. (1.5 m) of the inside walls of the swimming pool, spa, or hot tub. Run a wire from the external bonding lug to the bonding structure. See **Figure 3**.

**Note:** When the pump is started and stopped by removing power with a relay or timer, a two-pole device should be used to apply and remove power to both POWER LINE TERMINALS.



## External Control via RS-485

The following instructions only apply to pumps manufactured after December 2020. For all other pumps, refer to *External Control via Digital Inputs on page 6*.

When paired with the RS-485 Automation Wiring Kit (P/N 356324Z - Black) the pump can be externally controlled by a control system through an RS-485 communication cable.

**Note:** When externally controlled via RS-485, the pump can only operate in Speed Mode. To operate in Flow Mode digital inputs must be used.

**Note:** IntelliConnect® Control and Monitoring Systems can NOT externally control this pump via RS-485. The pump will need to be connected via digital inputs. Refer to *External Control via Digital Inputs, page 6*.

**Note:** If the pump is manually stopped using the **Start/Stop** button, the pump will not run until the **Start/Stop** button is pressed. If the Start/Stop LED is illuminated, the pump is active and can be controlled externally.

Only the GREEN and YELLOW conductors will be used to wire the pump for external control via RS-485. See **Figure 4**.

Refer to the control system manual for specific details on connecting and programming. Control systems using older firmware may require the pump to be designated as "IntelliFlo VS".

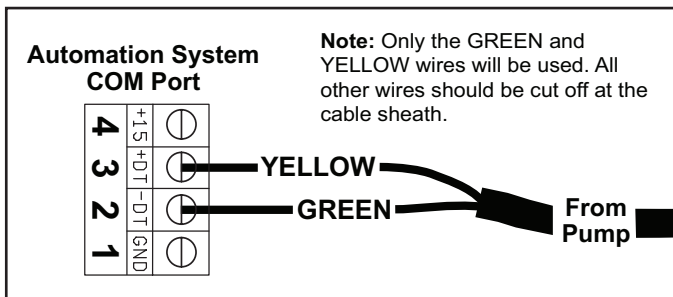
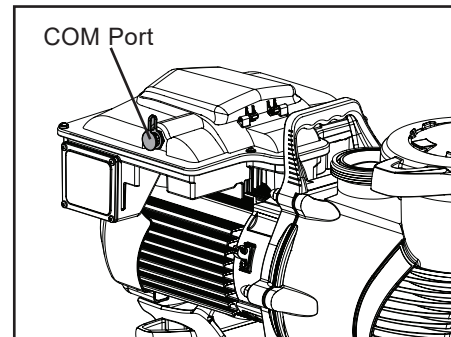

**Figure 4**

### TO WIRE FOR EXTERNAL CONTROL USING RS-485:

1. Route the communication cable from the Pump Com Port (**Figure 5**) to the control system wiring compartment.
2. Ensure the cable reaches all necessary terminals and cut to the necessary length.
3. Strip the cable 3/4" (19 mm).
4. Strip the 24 AWG GREEN and YELLOW conductors 1/2" (13 mm).
5. Cut back and terminate unused conductors according to local and national electrical codes.
6. Connect YELLOW and GREEN conductors to the control system as shown in **Figure 4**.
7. Program the pump's internal clock and pump address. Refer to *Setting the Clock and Pump Address, page 8*.
8. Set PROGRAM 1 to a speed of 0 RPM and duration of 24 hours. Refer to *Programming Custom Schedules on page 8*.
9. Disable priming at the pump. Priming duration and speeds will be controlled by the control system.
 

**Note:** If priming is not disabled at the pump, priming will continue to be controlled by the pump's programming. Refer to *Priming Adjustment, page 11*.
10. Plug the communication cable into the pump's Com Port (**Figure 5**).



**Figure 5**

## External Control via Digital Inputs

When paired with either the Digital Input Wiring Kit (P/N 353129Z - Almond) or RS-485 Automation Wiring Kit (P/N 356324Z - Black), the pump can be externally controlled by digital input signals.

**Note:** If the pump is manually stopped using the **Start/Stop** button, the pump will not run until the **Start/Stop** button is pressed. If the Start/Stop LED is illuminated, the pump is active and can be controlled externally.

The communication cable provided with these kits features a watertight connection that plugs into the Pump Com Port (**Figure 5** on page 5). The opposite end of the cable has either 6 or 8 conductors defined in **Table 1**.

A trigger signal is required to externally control the pump via digital inputs. This required output signal can to be provided in one of the following ways:

- By the pump drive. Refer to *Using the Pump's Output Signal*.
- By an external low voltage signal. Refer to *Using an External Input Signal on page 7*.

Definition	Signal Range	Wire Color	
		Wiring Kit 353129Z Almond	Wiring Kit 356324Z Black
+24V Output for Digital Inputs	0-20mA	Red	Red
RS-485 A	-7V to +12V	-	Yellow
RS-485 B	-7V to +12V	-	Green
PROGRAM 1 Digital Input	0, 5-30V AC/DC	Green	White
PROGRAM 2 Digital Input	0, 5-30V AC/DC	Yellow	Blue
PROGRAM 3 Digital Input	0, 5-30V AC/DC	Orange	Orange
QUICK CLEAN Digital Input	0, 5-30V AC/DC	Brown	Brown
Common Ground	0V	Black	Black

**Table 1**

## Using the Pump's Output Signal

1. Route the communication cable from the Pump Com Port (**Figure 5** on page 5) to the control system wiring compartment.
2. Ensure the cable reaches all necessary terminals and cut to the necessary length.
3. Strip the cable 3/4" (19 mm).
4. Strip all 24 AWG conductors 1/2" (13 mm).
5. **If using RS-485 Automation Wiring Kit (P/N 356324Z - Black):** Wire communication cable to control system as shown in **Figure 6A**.

**Note:** Unused conductors should be cut off and terminated according to local and national electrical codes.

**If using Digital Input Wiring Kit (P/N 353129Z - Almond):** Wire communication cable to control system as shown in **Figure 6B**.

6. Using the pump keypad, program the pump's internal clock. Refer to *Setting the Clock and Pump Address on page 8*.
7. Using the pump keypad, set PROGRAM 1 to 0 RPM and a duration of 24 hours. Refer to *Programming Custom Schedules on page 8*.
8. Using the pump keypad, disable priming. Refer to *Priming Adjustment on page 11*.
9. When ready to start the pump, place the pump into External Control Only mode. Refer to *External Control Only Mode on page 7*.
10. Plug the communication cable into the Pump Com Port.

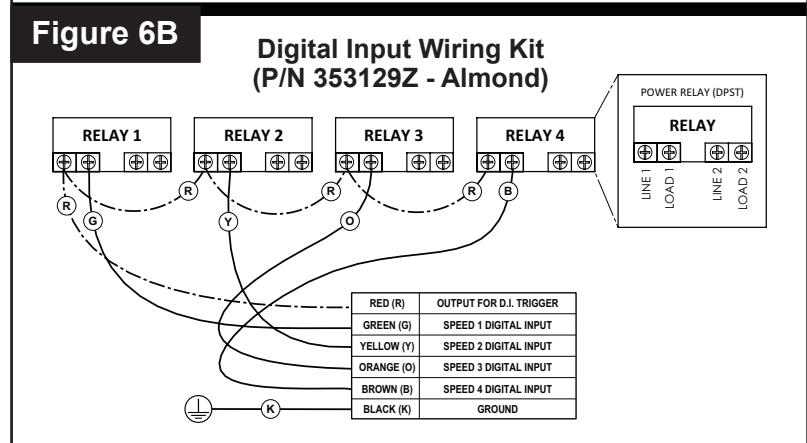
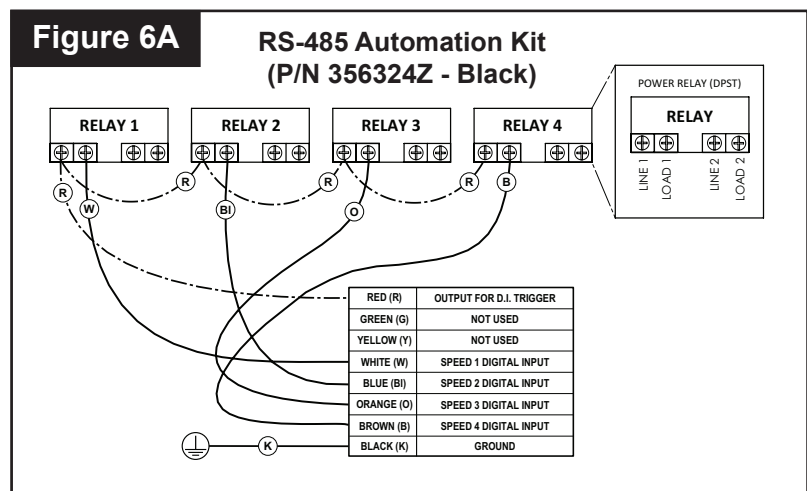

## Using an External Input Signal

When using an externally supplied low voltage signal for external control, input voltage must be within 5-30V AC/DC. The wiring kit's RED wire is only intended to carry the +24V output signal from the drive and will NOT be used.



The +24V signal (RED wire) is output from the drive only and should never be wired to another power supply. Improper wiring will damage the drive.

The external output signal can be regulated by switches or relays to initiate a desired pump function. If multiple digital inputs are active, the priority is: **QUICK CLEAN > PROGRAM 3 > PROGRAM 2 > PROGRAM 1.**

### TO WIRE FOR EXTERNAL CONTROL USING AN EXTERNAL INPUT SIGNAL:

1. Route the communication cable from the Pump Com Port (**Figure 5** on page 5) to the control system wiring compartment.
2. Ensure the cable reaches all necessary terminals and cut to the necessary length.
3. Strip the cable 3/4" (19 mm).
4. Strip all 24 AWG conductors 1/2" (13 mm).
5. **If using RS-485 Automation Wiring Kit (P/N 356324Z - Black):** Wire communication cable to control system as shown in **Figure 7A**.

**Note:** Unused conductors should be cut off and terminated according to local and national electrical codes.

**If using Digital Input Wiring Kit (P/N 353129Z - Almond):** Wire communication cable to control system as shown in **Figure 7B**.

6. Using the pump keypad, program the pump's internal clock. Refer to *Setting the Clock and Pump Address on page 8*.
7. Using the pump keypad, set PROGRAM 1 to a speed of 0 RPM and duration of 24 hours. Refer to *Programming Custom Schedules on page 8*.
8. Using the pump keypad, disable priming. Refer to *Priming Adjustment on page 11*.
9. When ready to start the pump, place the pump into External Control Only mode. Refer to *External Control Only Mode*.
10. Plug the communication cable into the Pump Com Port.

## External Control Only Mode

External Control Only mode will only allow the pump to run from external controls/inputs. When this mode is active the programmed pump schedule is deactivated, and user speed requests from the keypad will not be accepted. If the pump is stopped a user can still program the speeds for all four **PROGRAM** buttons.

**Note:** The following steps are required if controlling the pump via digital inputs, but optional if controlling via RS-485. The pump will prioritize RS-485 commands over digital input commands.

### TO ENABLE/DISABLE EXTERNAL CONTROL ONLY MODE:

1. If the pump is running or Start/Stop LED is illuminated, press the **Start/Stop** button to stop the pump.
2. Press and hold the **Start/Stop** button for 10 seconds to enable/disable External Control Only mode.  
The Ext. Control Only LED will illuminate if enabled. See **Figure 8**.
3. Press the **Start/Stop** button to start the pump.

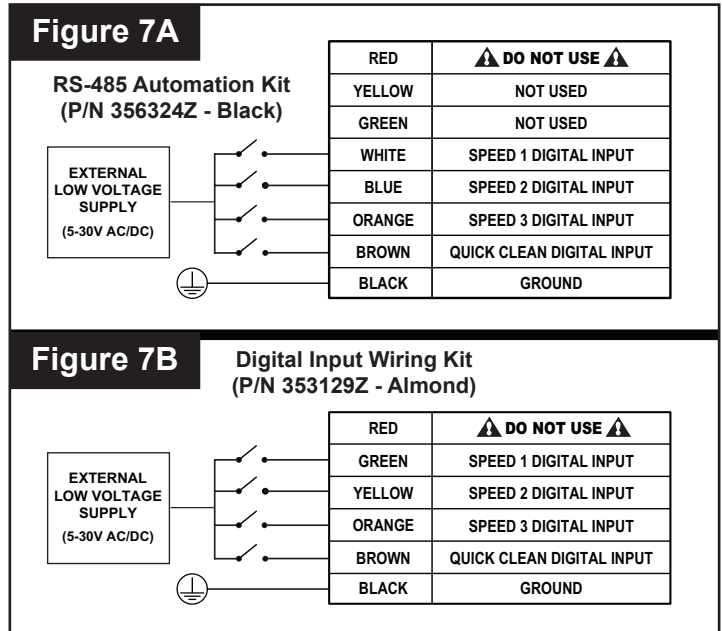

**Figure 8**

## OPERATION

### Setting the Clock and Pump Address

When power is first connected to the pump the clock will blink to indicate that it has not been set. Custom schedules are based on this clock setting, so the clock must be set first.

1. Press and hold **Display** for 3 seconds.
2. Use “+” and “-” to choose between a 12 or 24 hour time format.
3. Press **Display** to advance.
4. Use “+” and “-” to program the current time.  
**Note:** In the 12 hour time format AM/PM will display in the bottom right corner.
5. Press **Display** to advance.
6. Use “+” and “-” to adjust the screen backlight brightness.
7. Press **Display** to advance.
8. **If controlling pump via RS-485:** Use “+” and “-” to assign one of four pump addresses, then press **Display** to exit the menu.

**If controlling the pump via digital inputs or from the drive:** Press **Display** twice to exit the menu.

During a power outage, the drive will retain the clock setting for as long as 24 hours. If the power is out longer than 24 hours, the clock will have to be reset. If the drive has lost the user set time, the clock will continuously blink until the time is reset.

**Note:** When power is returned to the pump after a prolonged outage (24+ hours) the clock will automatically set itself to the PROGRAM 1 start time, blink and advance. The pump will also run the associated schedule from that start time.

### Using the Default Schedule

The default schedule is designed to provide filtration for a typical pool. See **Table 2** for default schedule.

**Note:** The **Start/Stop** button must be pressed, and the Start/Stop LED illuminated, for the pump to run.

	Duration (Hours)	Speed (RPM)
<b>PROGRAM 1</b>	24	1720
<b>PROGRAM 2</b>	0	2500
<b>PROGRAM 3</b>	0	3000

**Table 2**

### Programming Custom Schedules

To customize your pump’s schedule, the pump must be stopped. Ensure that the Start/Stop LED is not illuminated.

The clock must be set before programming a custom schedule, unless externally controlling the pump through digital inputs. When controlling the pump by digital inputs, schedules will be based on the automation system’s clock.

When programming, the LED next to the parameter you are editing will blink.

“Spd” - Run Speed

“Time” - Start Time

“Duration” - Run Time

#### TO PROGRAM A CUSTOM SCHEDULE:

1. Press **Start/Stop** to stop the pump.
2. Press “1”. The PROGRAM 1 LED and “Speed/FL%” parameter LED will blink while editing. See **Figure 9**.



**Figure 9**

3. Use “+” and “-” to adjust the PROGRAM 1 speed in RPM, or percentage of flow if operating in Flow Mode.

**Note:** If operating the pump with external controls, set PROGRAM 1 speed to 0 RPM.

4. Press “1”. The PROGRAM 1 start time will display. The “Time” parameter LED will begin to blink. See **Figure 10**.



**Figure 10**

5. Use “+” and “-” to adjust the PROGRAM 1 start time.

- Continue to next page -

## Programming Custom Schedules (cont.)

6. Press “1”. PROGRAM 1 duration will display. The “Duration” parameter LED will begin to blink. See **Figure 11**.



**Figure 11**

7. Use “+” and “-” to adjust the PROGRAM 1 duration in hours and minutes.  
**Note:** If operating the pump with external controls, program PROGRAM 1 duration to 24 hours.
8. PROGRAM 1 has been successfully programmed.  
**Note:** Pressing “1” will continue to cycle through these parameters, but changes are immediately saved as they are adjusted.
9. Press “2”. The PROGRAM 2 LED and “Speed/FL%” parameter LED will blink while editing.
10. Use “+” and “-” to adjust the PROGRAM 2 speed in RPM, or percentage of flow if operating in Flow Mode.
11. Press “2”. The PROGRAM 2 duration will display.  
**Note:** PROGRAM 2 and 3 do not have a start time, as they begin their duration after the previous PROGRAM 1 finishes.
12. Use “+” and “-” to adjust the PROGRAM 2 duration in hours and minutes.
13. Repeat steps 9-12 to program PROGRAM 3 and QUICK CLEAN.  
**Note:** The PROGRAM 3 duration will be limited to the remaining time in a 24 hour day. Any time in the 24 hour day not programmed into PROGRAM 1-3, the pump will not run.  
 $[ \text{PROGRAM 1} + \text{PROGRAM 2} + \text{PROGRAM 3} \leq 24 \text{ Hours} ]$
14. Press **Start/Stop** and ensure the Start/Stop LED is illuminated. The pump is now active and will run the custom schedule.  
**Note:** If the pump has been stopped via the **Start/Stop** button, the pump will not run until the **Start/Stop** button is pressed again. If the Start/Stop LED is illuminated, the pump is active and will run the programmed schedule.  
**Note:** If you do not want the pump to run during a specific time of the day, any of the PROGRAM can be programmed to 0 RPM. This ensures the pump will not run during the PROGRAM duration.

## Program Priorities (Non-External Control)

For schedule duration settings, PROGRAMS are prioritized as follows: PROGRAM 1 -> PROGRAM 2 -> PROGRAM 3. PROGRAM 1 is the highest priority, while PROGRAM 3 is the lowest.

The drive will not allow programming a schedule of more than 24 hours. When the 24th hour of duration is programmed, time will be taken from the lower priority PROGRAM and added to the PROGRAM being adjusted.

### **Example:**

#### Starting Schedule (Before Adjustment)

PROGRAM 1 duration = 20 hours  
 PROGRAM 2 duration = 2 hours  
 PROGRAM 3 duration = 2 hours

If PROGRAM 1 is set to run for 23 hours, PROGRAM 2 (lower priority) will automatically adjust to a 1 hour duration and PROGRAM 3 (lowest priority) will adjust to a 0 hour duration.

#### End Schedule (After Adjustment)

PROGRAM 1 duration = 23 hours  
 PROGRAM 2 duration = 1 hour  
 PROGRAM 3 duration = 0 hours

## Priming the Pump

**CAUTION** This pump is shipped with Priming mode ENABLED. Unless the Priming Speed has been modified, the pump will ramp up to 3450 RPM when powered on for the first time, and the Start/Stop button is pressed.

Before turning the pump ON, be sure the following conditions are met:

1. Open filter air relief valve.
2. Open valves.
3. Pool return is completely open and clear of any blockages.
4. Water in the pump basket.
5. Stand clear of the filter or other pressurized vessels.

**WARNING** DO NOT run the pump dry. If the pump is run dry, the shaft seal will be damaged and the pump will start leaking. If this occurs, the damaged seal must be replaced. ALWAYS maintain proper water level in your pool (half way up skimmer opening). If the water level falls below the skimmer opening, the pump will draw air through the skimmer, losing the prime and causing the pump to run dry, resulting in a damaged seal. Continued operation in this manner could cause a loss of pressure, resulting in damage to the pump case, impeller and seal and may cause property and personal injury.

Prime the pump before starting the pump for the first time. To avoid permanent damage to the pump, remove the lid and fill the strained pot up to the suction port with water. The strainer pot must be filled with water before initial start-up or after servicing.

### TO PRIME THE PUMP:

1. Press **Start/Stop** to stop the pump and disconnect all power to the pump at the circuit breaker.
2. Close all valves in suction and discharge pipes.
3. Relieve all pressure from the filtration system at the filter air relief valve.
4. Turn the strainer pot lid counter-clockwise and remove it from the pump. See **Figure 12**.
5. Fill the strainer pot up to the suction port with water.
6. Place the lid onto the strainer pot and tighten clockwise until the lid handles are horizontal.
7. Open all valves in suction and discharge pipes.
8. Open the filter air relief valve and stand clear of the filter.
9. Reestablish power to the pump and ensure green power light is on.
10. Press **Start/Stop** to start the pump. The pump will begin to prime (if enabled) and ramp up to the programmed priming speed.
11. When a steady stream of water comes out of the filter air relief valve, close the valve.
12. The pump will prime for 5 minutes.

**Note:** Do not allow the pump to run longer than 30 minutes before successfully priming. If the pump does not prime, check your priming speed (see *Priming Adjustment on page 11*) or refer to the *TROUBLESHOOTING on page 20*.

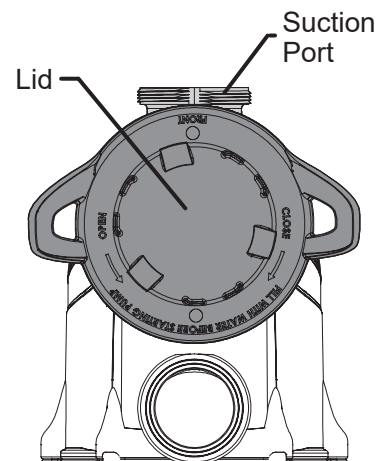

**Figure 12**

**CAUTION** Do not add chemicals to the system directly in front of pump suction. Adding undiluted chemicals may damage the pump and will void the warranty.

## Priming Adjustment

### CAUTION

This pump is shipped with Priming ENABLED. **The pump will ramp up to 3450 RPM when the pump is initially started.**

#### Before turning the pump ON:

1. Open filter air relief valve.
2. Open valves.
3. Pool return is completely open and clear of any blockages.
4. Water in the pump basket.
5. Stand clear of the filter or other pressurized vessels.

### WARNING

**DO NOT run the pump dry.** If the pump is run dry, the shaft seal will be damaged and the pump will start leaking. If this occurs, the damaged seal must be replaced. ALWAYS maintain proper water level in your pool (half way up skimmer opening). If the water level falls below the skimmer opening, the pump will draw air through the skimmer, losing the prime and causing the pump to run dry, resulting in a damaged seal. Continued operation in this manner could cause a loss of pressure, resulting in damage to the pump case, impeller and seal and may cause property and personal injury.

Priming will automatically run when the pump is started, except when running a Quick Clean cycle. Default Priming Speed is 3450 RPM, and will last for 5 minutes. The drive will display and cycle through “Pr1 -- Priming Speed, Pr1 -- Remaining Time”.

**If externally controlling the pump via an RS-485 connection and priming is enabled at both the pump and control system:** Both priming timers will start simultaneously, but pump priming settings will take priority over the control system settings.

**Note:** After the pump’s priming cycle has completed, if there is time remaining on the control system priming timer the pump will run the control system priming speed until the timer expires.

During the priming sequence, priming speed can be adjusted between 1700 and 3450 RPM using the “+” and “-” arrows. Setting the priming speed below 1700 RPM, will disable priming and the pump will immediately begin to run the scheduled speed.

When priming is disabled and the pump is started, the screen will display, “Pr1 -- OFF” for 10 seconds while running the scheduled speed (see **Figure 13**). This 10 second delay allows time to enable priming by pressing “+”.

If priming is re-enabled, the pump will transition from the scheduled speed to 1700 RPM. If necessary, priming speed can then be increased 1700 RPM by pressing “+”. The 5 minute priming countdown timer starts when priming is first engaged.

Priming time can change based on local environmental conditions such as water temperature, atmospheric pressure, and your pool’s water level. All of these things should be taken into consideration when setting the priming speed.

Test and verify priming speeds more than once, letting the water drain from the system in between each test.

**Note:** To prevent air from entering the system, the pump strainer pot should always be filled with water up to the bottom of the suction port.

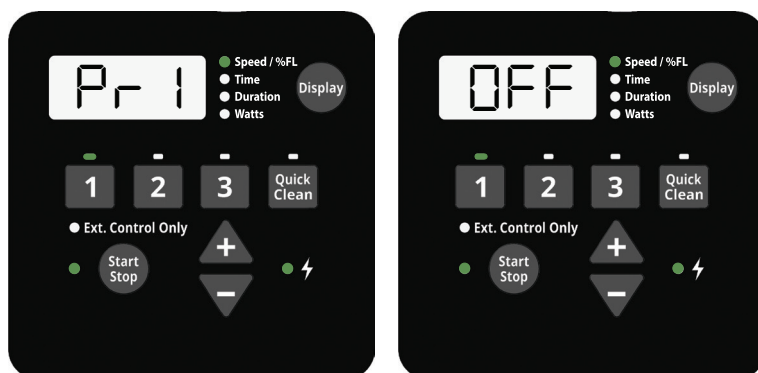

Figure 13

## Operating the Pump While Running

**CAUTION** If power is connected to the pump, pressing any of the following buttons referred to in this section could result in the motor starting. Failure to recognize this could result in personal injury or damage to equipment.

Pressing the **Display** button will cycle through the current parameters:

- **Speed / %FL** — current run speed or percent flow
- **Time** — current time of day
- **Duration** — amount of time remaining at the current PROGRAM
- **Watts** — amount of watts currently being consumed

Pressing any of the PROGRAM Buttons (“1”, “2”, “3”, “Quick Clean”) while the pump is running will act as a temporary override. The pump will run the speed and duration programmed for that button. Once completed the pump will return to the appropriate point in the programmed schedule.

**Note:** If PROGRAM speeds are adjusted while the pump is running, the pump will run the entered speed for the rest of the PROGRAM duration, but will not save the adjustments.

**Exception: QUICK CLEAN Speed and Duration adjustments will always be immediately saved.**

### Quick Clean

During a Quick Clean cycle, pressing “+” or “-” will change the speed accordingly. Pressing **Quick Clean** within 10 seconds after will allow for adjustment of the Quick Clean duration using the “+” and “-” arrows. These changes will be saved immediately and are the new settings for Quick Clean. Pressing **Quick Clean** again will cycle through the two Quick Clean settings. The pump will exit editing mode if no buttons are pressed within 10 seconds.

**Note:** While in keypad lockout mode the quick clean feature is enabled and the “+” and “-” buttons can be used to make temporary changes.

A Quick Clean cycle can be stopped by pressing and holding **Quick Clean** for 3 seconds. The pump will return to the appropriate point in its 24-hour schedule.

When a connected control system is in Service Mode, a pump connected via RS-485 can still run its Quick Clean program. Once Service Mode is enabled the pump display will flash between “SEr” and the current Quick Clean speed (**Figure 14**). Once Service Mode is disabled the pump will resume normal operation.

**Note:** Quick Clean speed will read 0 when Quick Clean is off.



**Figure 14**

## Programming Quick Clean

The pump is equipped with a Quick Clean feature, which can be engaged to temporarily run at higher or lower speeds ranging from 300 to 3450 RPM.

At the end of a Quick Clean cycle, the pump will automatically return to the appropriate point in its programmed schedule.

**Note:** Pressing and holding **Quick Clean** for more than 3 seconds will cancel a Quick Clean cycle. The pump will then return to the appropriate point in its programmed schedule.

### TO PROGRAM QUICK CLEAN:

1. Press **Start/Stop** to stop the pump.
2. Press **Quick Clean**. The **Quick Clean** LED and “Spd / %FL” parameter LED will blink while editing. See **Figure 15**.



**Figure 15**

3. Use “+” and “-” to adjust the Quick Clean speed in RPM.
4. Press **Quick Clean**. The Quick Clean duration will display. The “Duration” parameter LED will blink while editing. See **Figure 16**.



**Figure 16**

5. Use “+” and “-” to adjust the Quick Clean duration in hours and minutes.

**Note:** It is recommended that you do not set the Quick Clean duration to 0 HRS. Setting the Quick Clean duration to 0 HRS will prevent edits to the duration setting while the motor is running. The motor will need to be stopped.

**Note:** Quick Clean duration does not affect the start or stop times of the 24-hour schedule. For example, if Quick Clean runs during a period overlapping with a later part of PROGRAM 1 and an early part of PROGRAM 2, the start time of PROGRAM 3 is not affected.



## Keypad Lockout

**CAUTION** Keypad lockout will not prevent the motor from being stopped by pressing the **Start/Stop** button. If the pump is stopped with the **Start/Stop** button during Keypad Lockout, it can not be restarted until the keypad is unlocked.

The pump features a Keypad Lockout mode. Keypad Lockout is intended to prevent unwanted changes to pump settings. When locked, the pump will only respond to:

- Pressing **Display** to cycle through current pump information.
- Pressing **Start/Stop** to stop the pump and/or enable/disable external control.
 

**Note:** The pump can not be manually restarted using the **Start/Stop** button until the keypad is unlocked.
- Pressing **Quick Clean** to start a quick clean cycle or making temporary adjustments to quick clean settings.
- Any drive-programmed or external control schedules, as long as the Start/Stop LED is illuminated.

### TO PROGRAM A LOCKOUT CODE:

1. Press and hold “1” and **Quick Clean** simultaneously for 3 seconds. “EntEr Loc CodE” will scroll across the screen.
2. Use the “1”, “2”, “3” and **Quick Clean** buttons, enter your desired four-digit keypad lockout code.
3. “Loc on” will scroll across the screen. Keypad Lockout is now active.

### TO UNLOCK THE PUMP:

1. Press and hold the “1” and **Quick Clean** buttons for at least 3 seconds. “Enter Loc Code” will scroll across the screen.
2. Use the “1”, “2”, “3” and **Quick Clean** buttons to enter your four-digit keypad lockout code.

**Note:** If the lockout code is entered incorrectly, “Loc Err” will scroll across the screen. Repeat the steps above to reenter your code.

**Note:** If your custom lockout code is forgotten, press **Quick Clean** -> **Quick Clean** -> “2” -> **Quick Clean** to erase the existing code and unlock the keypad.

3. “Loc oFF” will scroll across the screen. The keypad is now unlocked.

## Factory Reset

The drive can be reset to factory settings if necessary. A Factory Reset will remove all programmed settings and schedules, except for the clock. Be sure a factory reset is necessary before performing a Factory Reset, as the results are immediate.

**Note:** A Factory Reset can not be performed when in Keypad Lockout mode.

### TO PERFORM A FACTORY RESET:

1. Press **Start/Stop** to stop the pump.
2. Record all of the custom schedule settings and the priming speed in **Table 3**. These settings can be found by pressing the “1”, “2”, “3”, and “**Quick Clean**” buttons and cycling through all the screens.
3. Press and hold “1”, “2”, “3”, and “**Quick Clean**” for 3 seconds.
4. The screen will display “FACT rSt” if factory reset is successful. See **Figure 17**.
5. Be sure to reprogram the schedule and priming speed after the factory reset.

The pump must be turned back on with the **Start/Stop** button before it will run again. The pump will run the programmed schedule upon initial start-up.

	Speed / Flow (RPM / %)	Duration (Hours)	Start Time (Time Clock)
PROGRAM 1			
PROGRAM 2			
PROGRAM 3			
QUICK CLEAN			
PRIMING SPEED			

Table 3

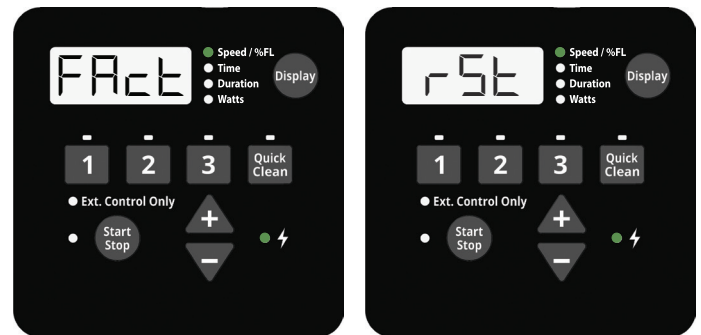

Figure 17

## Operating the Pump in Flow Mode

When connected to an inline 4-20mA flowmeter, this pump is capable of maintaining a constant flow based on the needs of your pool system.

Connecting a flowmeter and operating the pump in flow mode will require the purchase of:

- Digital Input Wiring Kit (P/N 353129Z - Almond) or RS-485 Automation Wiring Kit (P/N 356324Z - Black).  
*Flow mode operation is not possible if controlling the pump via RS-485.*
- A 4-20mA Flowmeter (Pentair recommends P/N 97014-4203KIT)

## Flow Mode Setup and Configuration

Before beginning flow mode setup and configuration, ensure the pool filter has been backwashed and all pump and skimmer baskets are free of debris.

1. Press **Start/Stop** to stop the pump.
2. Following the installation instructions given in the flowmeter's installation guide, install an inline 4-20mA flowmeter into the plumbing.
3. Using the Digital Input Wiring Kit, wire the flowmeter to the pump's digital input port. See **Figure 18A**.

**Note:** Flow mode is not compatible with external control via RS-485. However, a flowmeter can still be connected. See **Figure 18B**.

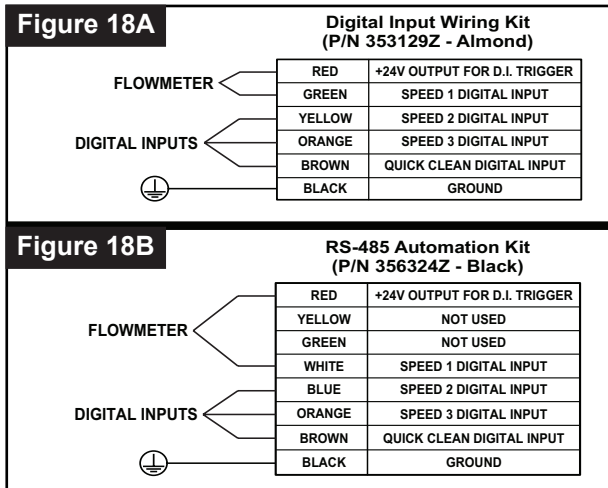

4. Press and hold **Display** for 3 seconds.
5. Press **Display** three times to access the Speed or Flow mode selection screen. "Spd" will display.

## Flow Mode Setup and Configuration (cont.)

6. Use "+" and "-" to scroll to "Flo". See **Figure 19**.

**Note:** This option will not be available unless a 4-20mA flowmeter is connected to the pump.



**Figure 19**

7. Press **Display**. The Flow Mode High Speed screen.
8. Use "+" and "-" to set a high speed for flow mode between 2000 and 3450 RPM.
9. Press **Display**. "Press Start" will scroll across the screen.
10. Press **Start/Stop**. The pump will ramp up to the programmed maximum speed, then "Config Flo Sensor" will scroll across the screen.
11. At the flowmeter, configure the flowmeter:
  - K Factor:** Refer to flowmeter manual
  - Averaging:** 10-30 (20 is recommended)
  - Sensitivity:** Refer to flowmeter manual
  - 4-Set:** 0 GPM
  - 20-Set:** GPM displayed while pump motor is at maximum speed set in step 8.

**Note:** Flowmeter configuration will timeout at the drive after 10 minutes. If this occurs, repeat steps 4 through 10.

**Note:** The flowmeter 20-Set will need to be reconfigured each time the system's filter is cleaned.

- Continue to next page -

## Flow Mode Setup and Configuration (cont.)

12. At the pump, press **Display** to advance.

**Note:** If the pump displays “LoFlo” or “HiFlo” and a percentage other than “100” (see **Figure 20**), adjust 20-set setting at the flowmeter until the pump displays “100”.



**Figure 20**

13. “Aver” will display (see **Figure 21**). Use “+” and “-” to match the flowmeter’s averaging value.



**Figure 21**

14. Press **Display**. “Auto Tuning” will scroll across the screen as the pump auto tunes. The motor will drop to half speed and then slowly ramp down until the minimum controllable flow is found.

**Note:** Auto Tuning process will take several minutes to complete, or much longer in installations with longer plumbing systems.

15. Motor will stop when Auto Tuning completes. Flow Mode setup is now complete.

16. Refer to *OPERATION on page 8* to continue pump programming.

## Adjusting Flow Setting

1. Use “+” and “-” to increase or decrease the Flow Percentage. This percentage is based on the high speed set during Flow Mode setup and configuration.

**Example:** If flow mode maximum speed is 3000 RPM, lowering flow percentage to “50” will decrease the motor RPMs until the pump is producing 50% of the flow created at 3000 RPM.

## MAINTENANCE

**⚠ WARNING** DO NOT open the strainer pot if pump fails to prime or if pump has been operating without water in the strainer pot. Pumps operated in these circumstances may experience a build up of vapor pressure and may contain scalding hot water. Opening the pump may cause serious personal injury. In order to avoid the possibility of personal injury, make sure the suction and discharge valves are open and strainer pot temperature is cool to touch, then open with extreme caution.

**⚠ WARNING** Always disconnect power to the pump at the circuit breaker and disconnect the digital input cable before servicing the pump. Failure to do so could result in death or serious injury to service people, users or others due to electric shock. Read all servicing instructions before working on the pump.

**⚠ CAUTION** To prevent damage to the pump and for proper operation of the system, clean pump strainer and skimmer baskets regularly.

### Cleaning the Pump Strainer Basket

The strainer pot is located at the front of the pump and houses the pump strainer basket.

The strainer basket can be viewed through the strainer pot lid and should be visually inspected at least once a week. Regularly emptying and cleaning the strainer basket will lead to higher filter and heater efficiency and prevent unnecessary stress on the pump motor.

#### TO CLEAN THE STRAINER BASKET:

1. Press **Start/Stop** to stop the pump and shut off all electrical power to the pump at the circuit breaker.
2. Open the filter air relief valve and relieve all pressure from the filtration system.
3. Turn the strainer pot lid counter-clockwise and remove it from the pump.
4. Remove debris and rinse out the basket. Replace the basket if it is cracked or damaged.
5. Place the basket into the strainer pot. Ensure the notch in the bottom of the basket is aligned with the rib in the bottom of the strainer pot.
6. Fill the strainer pot with water up to the inlet port.
7. Clean the lid O-ring and sealing surface of the strainer pot.
 

**Note:** It is important to keep the lid O-ring clean and well lubricated.
8. Reinstall the lid by placing it onto the strainer pot and tightening clockwise until the lid handles are horizontal.
 

**Note:** Ensure the lid O-ring is properly placed and is not being pinched between the lid and strainer pot.

**Note:** Ensure that the side of the lid marked "Front" is positioned at the front of the pump.
9. Open the filter air relief valve and stand clear of the filter.
10. Reestablish electrical power to the pump at the circuit breaker and start the pump.
11. When a steady stream of water flows from the filter air relief valve, close the valve.

**⚠ WARNING** THIS SYSTEM OPERATES UNDER HIGH PRESSURE. When any part of the circulating system is serviced, air can enter the system and become pressurized. Pressurized air can cause the lid to separate which can result in serious injury, death, or property damage. To avoid this potential hazard, follow above instructions.



### Winterizing

You are responsible for determining when freezing conditions may occur. If freezing conditions are expected, take the following steps to reduce the risk of freeze damage. **Freeze damage is not covered under warranty.**

In mild climate areas, when temporary freezing conditions may occur, run your filtering equipment all night to prevent freezing.

#### TO PREVENT FREEZE DAMAGE:

1. Press the **Start/Stop** button to stop the pump.
2. Disconnect all power to the pump at the circuit breaker.
3. Relieve all pressure from the filtration system at the filter air relief valve.
4. Remove both drain plugs from the bottom of the strainer pot and drain the pump. Store the plugs in the strainer basket.
5. Cover the motor to protect it from severe rain, snow and ice.

**Note:** Do not wrap motor with plastic or other air tight materials during winter storage. Never cover the motor when operating or expecting operation.

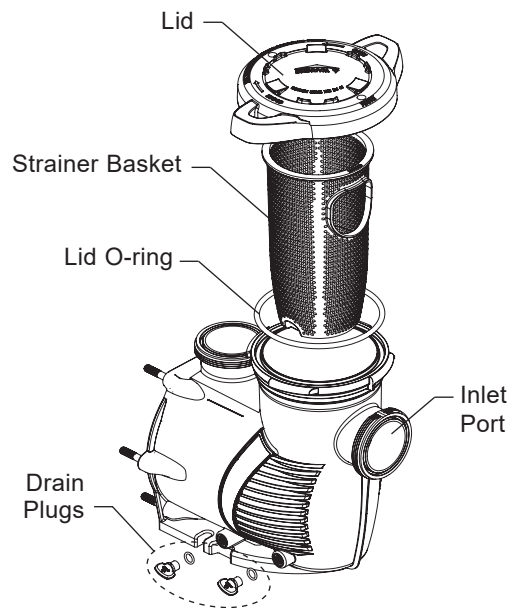

**Strainer Pot Assembly**



**WARNING** Always disconnect power to the pump at the circuit breaker and disconnect the digital input cable before servicing the pump. Failure to do so could result in death or serious injury to service people, users or others due to electric shock. Read all servicing instructions before working on the pump.



**WARNING** **DO NOT** open the strainer pot if pump fails to prime or if pump has been operating without water in the strainer pot. Pumps operated in these circumstances may experience a build up of vapor pressure and may contain scalding hot water. Opening the pump may cause serious personal injury. In order to avoid the possibility of personal injury, make sure the suction and discharge valves are open and strainer pot temperature is cool to touch, then open with extreme caution.



**CAUTION** Be sure not to scratch or mar the polished shaft seal faces; seal will leak if faces are damaged. The polished and lapped faces of the seal could be damaged if not handled with care.

## Motor and Drive Care

### Protect from heat

1. Shade the motor from the sun.
2. Any enclosure must be well ventilated to prevent overheating.
3. Provide ample cross ventilation.

### Protect against dirt

1. Protect from any foreign matter.
2. Do not store (or spill) chemicals on or near the motor.
3. Avoid sweeping or stirring up dust near the motor while it is operating.
4. If a motor has been damaged by dirt it may void the motor warranty.
5. Clean the lid, O-ring, and sealing surface of the strainer pot regularly.

### Protect against moisture

1. Protect from splashing or sprayed water.
2. Protect from extreme weather.
3. If motor internals have become wet - let them dry before operating. Do not allow the pump to operate if it has been flooded.
4. If a motor has been damaged by water it may void the motor warranty.

## Pump Disassembly

### TOOLS REQUIRED:

- 3/8-inch socket wrench
- 9/16-inch open-end wrench
- 9/64-inch hex key wrench
- 1/4-inch hex key wrench
- T20 star-head and flat-head screwdrivers
- Torque wrench

### TO DISASSEMBLE THE PUMP:

1. Press **Start/Stop** to stop the pump and disconnect all power to the pump at the circuit breaker.
2. Disconnect any digital inputs or communication cables from the pump.
3. Close all valves in suction and discharge pipes and relieve all pressure from the system.
4. Remove both drain plugs from the bottom of the strainer pot.

## Pump Disassembly (cont.)

5. Remove the four star-head Drive Cover Screws from the top of the Drive Cover. **Wait five minutes after disconnecting the power before removing the drive cover.**
6. Disconnect the keypad from the drive and set it aside
7. Carefully disconnect the four white motor connectors.
 

**Note:** Take note of which terminal each connector is paired with. Each connector must be reconnected to the same terminal when reassembling.
8. Remove the four star-head Drive-to-Motor Screws securing the drive to the motor. Two screws are located under the drive and two are located inside the drive.
9. Lift the drive from the motor and set it aside.
10. Using a 9/16-inch open end wrench remove the six nuts and washers securing the Strainer Pot to the motor assembly.
11. Gently pull the two pump halves apart.
12. Using a 9/64-inch hex key wrench, remove the three Diffuser Screws securing the diffuser to the Seal Plate and remove the Diffuser.
13. Hold the impeller in place by hand. Using a 3/8-inch socket wrench, remove the impeller screw and washer.
 

**Note:** The screw is a left-handed thread and loosens in a clockwise direction.

**Note:** If the impeller screw has a plastic head a 3/4-inch socket is required. This screw will also include an O-ring instead of a washer.



**CAUTION** The impeller may have sharp edges that could potentially cut or scratch the user's hands. Safety gloves are recommended when holding the impeller during disassembly and reassembly.

14. Using a 1/4-inch hex key wrench, hold the motor shaft in place at the back of the motor. Turn the impeller counter-clockwise and remove it from the shaft.
15. Using a 9/16-inch wrench, remove the four motor nuts and washers securing the seal plate to the motor.
16. If replacing the shaft seal, continue to *Shaft Seal Replacement* on the next page. Otherwise, continue to *Pump Reassembly* when necessary.

## Shaft Seal Replacement

The Shaft Seal consists of two halves, a rotating spring seal and a fixed ceramic seal. The shaft seal may occasionally become damaged and require replacement.

**CAUTION** Scratching, marring or otherwise damaging the polished shaft seal faces will cause the seal to leak. Always handle the shaft seal faces with care and clean them thoroughly before reassembling the pump.

1. Ensure you have completed all pump disassembly instructions on the previous page.
2. Remove the old Spring Seal from the impeller shaft with a pair of pliers.
 

**Note:** When removing the spring seal the inner sleeve of the seal may stick to the shaft. Ensure it is removed before installing the new spring seal.
3. Place the seal plate face down on a flat surface and tap out the old ceramic seal with a flat-blade screwdriver.
4. Flip the seal plate over and thoroughly clean the seal cavity.
5. Lightly lubricate the outside rubber surface of the new ceramic seal with water.
6. **With the White Ceramic Face upwards**, firmly press the new Ceramic Seal into the seal plate cavity with your thumbs.
7. Thoroughly clean the seal face with a clean cloth.
8. Using a 9/16" wrench, secure the seal plate to the motor with the four motor bolts. Tighten to 75-80 in-lbs. (86-92 kg/cm).
9. **With the Flat Face towards the impeller**, slide the new spring seal onto the impeller shaft.
10. Thoroughly clean the seal face with a clean cloth
11. Hold the motor shaft in place at the rear of the motor and hand tighten the impeller clockwise onto the motor shaft.
12. Continue reassembling the pump according to the instructions given in *Pump Reassembly*.

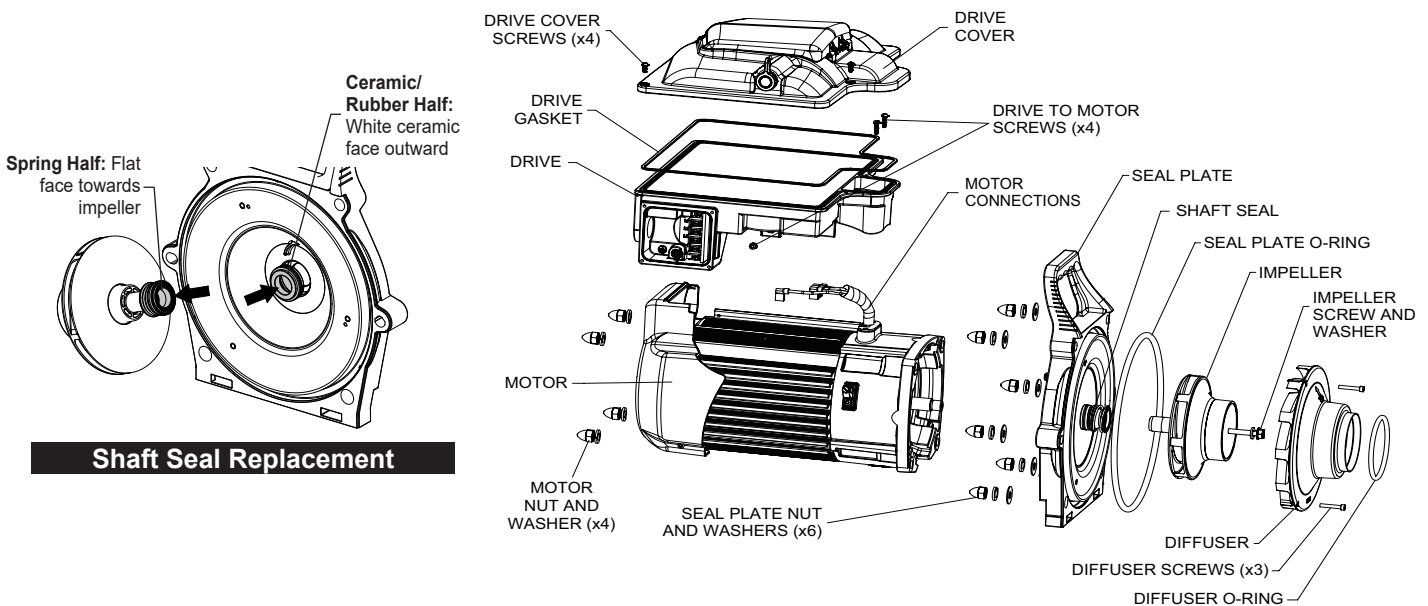

## Pump Reassembly

1. Using a 9/16" wrench, secure the seal plate to the motor with the four motor nuts. Tighten to 75-80 in-lbs. (86-92 kg/cm).
2. Hold the motor shaft in place at the rear of the motor and hand tighten the impeller clockwise onto the motor shaft.
3. Continue to hold the motor shaft in place and reinstall the impeller screw and washer.

**Note:** The impeller screw is reverse thread and tightens counter-clockwise.

**Note:** Some pumps contain an O-ring instead of a washer. Before reassembling, inspect the O-ring for damage and replace if needed.

**CAUTION** The impeller may have sharp edges that could potentially cut or scratch the user's hands. Safety gloves are recommended when holding the impeller during disassembly and reassembly.

4. Secure the diffuser onto the seal plate with the three diffuser screws. Ensure the plastic pins and holding screw inserts are aligned (see "TOP" indicator).
 

**Note:** Ensure that the seal plate and diffuser O-rings are clean and free of debris.
5. Using a 9/16-inch open-end wrench, secure the motor assembly to the strainer pot with the six seal plate nuts and washers. Tighten to a maximum of 100 in-lbs (115 kg/cm).
6. Carefully feed the motor connections through the opening in the front of the drive.
7. Secure the drive onto the motor with the four drive-to-motor screws.
8. Reconnect the keypad to the drive.
9. Ensure the drive gasket is correctly seated and secure the drive cover using the four drive cover screws.
10. Reinstall both drain plugs and fill the pump with water.
11. Prime the system. See page 10 for priming instructions.

## Replacing the Drive Assembly

### TO REMOVE THE EXISTING DRIVE ASSEMBLY:

1. If possible, record your programmed schedule and priming speed before proceeding.
2. Disconnect power to the pump at the circuit breaker. **Wait five minutes after disconnecting the power before removing the drive cover.**
3. Using a #2 Phillips-head screwdriver, remove the field wiring compartment cover from the side of the drive. Place the cover and all screws aside.
4. Disconnect and remove field wiring, strain reliefs and/or conduit from the drive.
5. Using a T20 star-head screwdriver, remove the four Drive Cover Screws (**Figure 22**).
6. Gently lift the drive cover and disconnect the keypad cable from the Keypad Terminal (**Figure 23**). Place the drive cover aside.
7. Carefully disconnect the four white Motor Connectors from their flag terminals.

**Note:** Take note of which terminal each connector is paired with. Each connector must be reconnected to the same terminal.

8. Using a T20 star-head screwdriver, remove the two Front Drive-to-Motor Screws (**Figure 23**).
9. Using a T20 star-head screwdriver, remove the two Rear Drive-to-Motor Screws (**Figure 24**) from underneath the drive.
10. Lift the drive away from the motor, carefully guiding the motor cables through the opening in the front of the drive. Place the old drive aside.

### TO REMOVE THE NEW DRIVE ASSEMBLY:

11. Place the new drive onto the motor, carefully feeding the Motor Connections through the opening in the front of the drive.
12. Reinstall the four Drive-to-Motor Screws (**Figure 23** and **Figure 24**).
13. Referring back to the notes taken in Step 7, plug each motor cable into its corresponding flag terminal.
14. Reconnect the drive cover's keypad connector to the drive and seat the drive cover onto the drive body.
15. Reinstall the four Drive Cover Screws (**Figure 22**).
16. The field wiring compartment contains a partially installed surge jumper. Finish installing the surge jumper between the bottom two Screw Terminals (**Figure 24**).
17. Reconnect the Main Power supply and strain relief or conduit for the electrical wires.
18. Reinstall the field wiring compartment cover using the four cover screws.
19. Return power to the pump at the circuit breaker.
20. Your pump's time, schedule and priming speed will need to be reprogrammed. Refer to the *OPERATION* section for programming procedures.

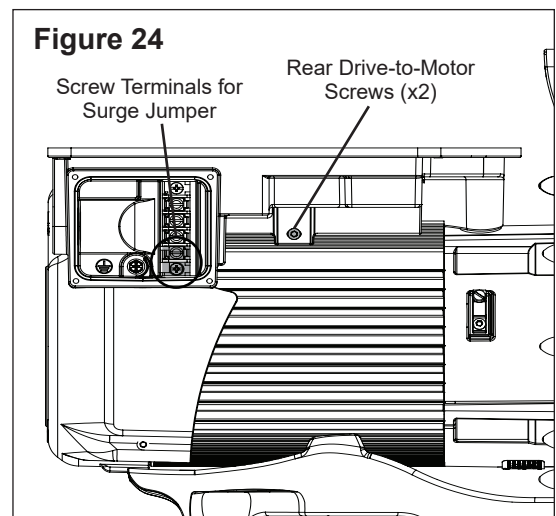
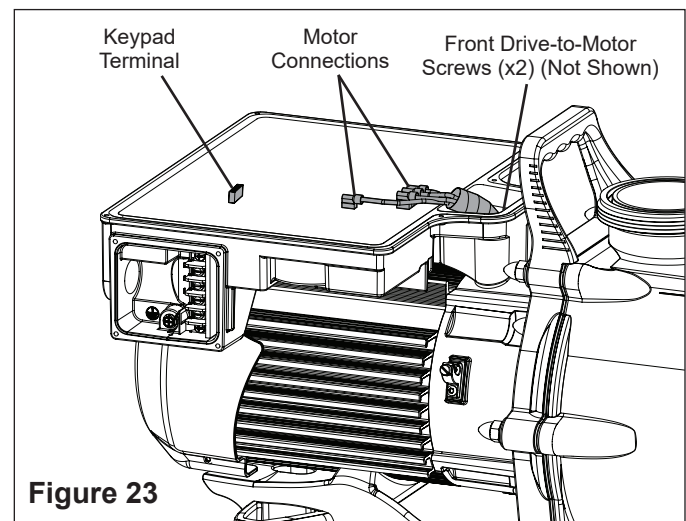
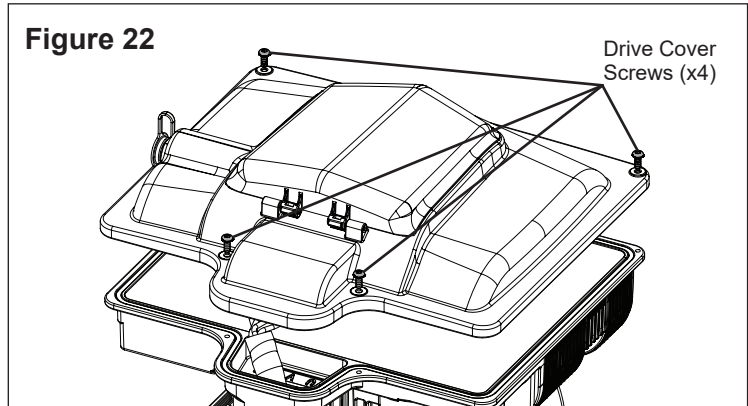

## TROUBLESHOOTING

### WARNING

Always disconnect power to the pump at the circuit breaker and disconnect the digital input cable before servicing the pump. Failure to do so could result in death or serious injury to serviceman, pool users or others due to electric shock. DO NOT attempt to adjust or service without consulting your dealer or a qualified pool technician. Read the entire Installation & User's Guide before attempting to use, service, or adjust the pool filtering system or heater.

Problem	Possible Cause	Corrective Action
Pump failure.	Pump will not prime - Air leak in suction.	Check suction piping and valve glands on any suction gate valves. Secure lid on pump strainer pot and be sure lid gasket is in place. Check water level to be sure skimmer is not drawing air.
	Pump will not prime - Not enough water.	Be sure the suction lines, pump, strainer, and pump volute are full of water. Be sure valve on suction line is working and open (some systems do not have valves). Check water level to make sure water is available through skimmer.
	Pump strainer basket is clogged.	Clean pump strainer basket.
	Pump strainer gasket is defective.	Replace gasket.
Reduced capacity and/or head.	Air pockets or leaks in suction line.	Check suction piping and valve glands on any suction gate valves. Secure lid on pump strainer pot and be sure lid gasket is in place. Check water level to be sure skimmer is not drawing air.
	Clogged impeller.	Turn off electrical power to the pump. Disassemble (see <i>Pump Disassembly on page 17</i> ) Clean debris from impeller. If debris cannot be removed, complete the following steps: <ol style="list-style-type: none"> <li>1. Remove left hand thread anti-spin bolt and O-Ring.</li> <li>2. Remove, clean, and reinstall impeller.</li> <li>3. Reassemble (see <i>Pump Disassembly on page 17</i>)</li> </ol>
	Pump strainer basket clogged.	Clean suction trap. Clean pump strainer basket.
Pump fails to start.	Main voltage is not present.	<ol style="list-style-type: none"> <li>1. Replace fuse, reset breaker/GFCI.</li> <li>2. Tighten main wire connections.</li> </ol>
	Pump shaft is locked.	Check if the pump can be rotated by hand and remove any blockage.
	Pump shaft is damaged.	Replace pump.
Pump runs then stops.	"0004" over-temperature alarm.	Check that back of pump is free from dirt and debris. Use compressed air to clean.
	"0017" over-current alarm.	Inspect drive to motor connection terminals.
Pump is noisy.	Debris in contact with fan.	Check that back of pump is free from dirt and debris. Use compressed air to clean.
	Debris in strainer basket.	Clean pump strainer basket.
	Loose mounting.	Check that mounting bolts of pump and pump are tight.
Inadequate circulation.	Filter or pump basket dirty.	Check pump strainer basket; if logged, turn pump off and clean basket. Check and clean pool filter.
	Suction/discharge piping is too small.	Increase piping size.
	Speed is set too slow for proper filtration cycle.	Increase filtration run time.



## Troubleshooting, (continued)

Problem	Possible Cause	Corrective Action
Pump runs without flow.	Impeller is loose.	Check that pump is spinning by looking at fan on back of motor. If so, check that pump impeller is correctly installed.
	Air leak.	Check plumbing connections and verify they are tight.
	Clogged or restricted plumbing or strainer basket.	Check for blockage in strainer basket or suction side piping. Check for blockage in discharge piping, including partially closed valve or dirty pool filter.
“LoFlo” or “HiFlo” alarm.	Flowmeter 20-set setting is too high (Low Flow alarm) or too low (High Flow alarm).	Clean the pool filter, pump strainer basket and all skimmer baskets. Recalibrate the flowmeter 20-set (refer to <i>Flow Mode Setup and Configuration on page 14</i> ).
Electrical problem.	Could appear as a “000E” low voltage alarm.	Check voltage at motor terminals and at panel while pump is running. If low, see wiring instructions or consult power company. Check for loose connections.
	Could appear as “0017” overheat alert.	Check line voltage; if less than 90% or more than 110% of rated voltage consult a licensed electrician. Increase ventilation. Reduce ambient temperature. Inspect drive to motor connection terminals. Motor runs too hot. Turn power to motor off. Check for proper voltage. Check for proper impeller or impeller rubbing.
Mechanical troubles and noise.	The pump motor is running but with loud noise.	If suction and discharge piping are not adequately supported, pump will be strained. Do not mount pump on a wooden platform! Securely mount on concrete platform for quietest performance.
	Foreign matter (gravel, metal, etc.) in pump impeller.	Disassemble pump, clean impeller, follow pump service instructions for reassembly.
	Cavitation.	Improve suction conditions. Increase pipe size. Decrease number of fittings. Increase discharge pressure.
	Squeaking noise, especially evident at pump start-up or slow down.	Inspect motor slinger and motor shaft seal behind the slinger (NOT the pump’s shaft seal). Apply lubrication to the motor shaft rubber seals.
Pump does not respond to external controls.	Improper external control, digital input or flow control setup.	Be sure that the digit input cable is connected at both ends.

## Faults and Alarms

If an alarm is triggered the drive's LCD screen will display the fault code text and the pump will stop. Disconnect power to the pump and wait until the keypad LEDs have all turned off. At this point, reconnect power to the pump. If the error has not cleared then proper troubleshooting will be required. Use the error description table below to begin troubleshooting.

FAULT CODE	DESCRIPTION
000A	Absolute L4 inductor temperature limit exceeded
000B	DC bus over voltage detected
000C	DC bus under voltage detected
000D	Absolute AC line over voltage detected
000E	Absolute AC line under voltage detected
000F	Internal voltage ref out of range
001A	Input bypass relay fault detected
0002	Absolute phase current limit exceeded
0004	Absolute Power Module temperature limit exceeded
0006	Absolute Power Factor Correction (PFC) temperature limit exceeded
0008	Absolute Diode Bridge temperature limit exceeded
0010	External voltage ref out of range
0011	Module therm out of range
0012	PFC therm out of range
0013	Bridge therm out of range
0014	L4 Inductor therm out of range
0015	Current offset out of range
0016	Motor start fault detected
0017	Power module over current detected
0018	3 phase current imbalance detected
0019	Module fault test failure
0021	Communication link between HMI and motor control has been lost

**0021 – Communication Link between the HMI and Motor control has been lost:** Check the jacketed wire on the back side of the keypad inside the drive top cover. Ensure that the 5-pin connector is properly plugged into the socket and that there is no damage to the cable.

**0017 – Power Module over current detected:** If this error displays multiple times, then there may be a problem with the pump's rotating assembly. Please disassemble the pump and investigate to see if there is a problem with the impeller or shaft seal. See *Pump Disassembly on page 17* for instructions for disassembling the pump.

**000E – Absolute AC Under Voltage Detected:** Indicates that the supply voltage has dropped below the operating range of 187v. This could be caused by normal voltage variation and will clear itself. Otherwise there could be excess voltage sag caused by improper installation or improper supply voltage.

# REPLACEMENT PARTS

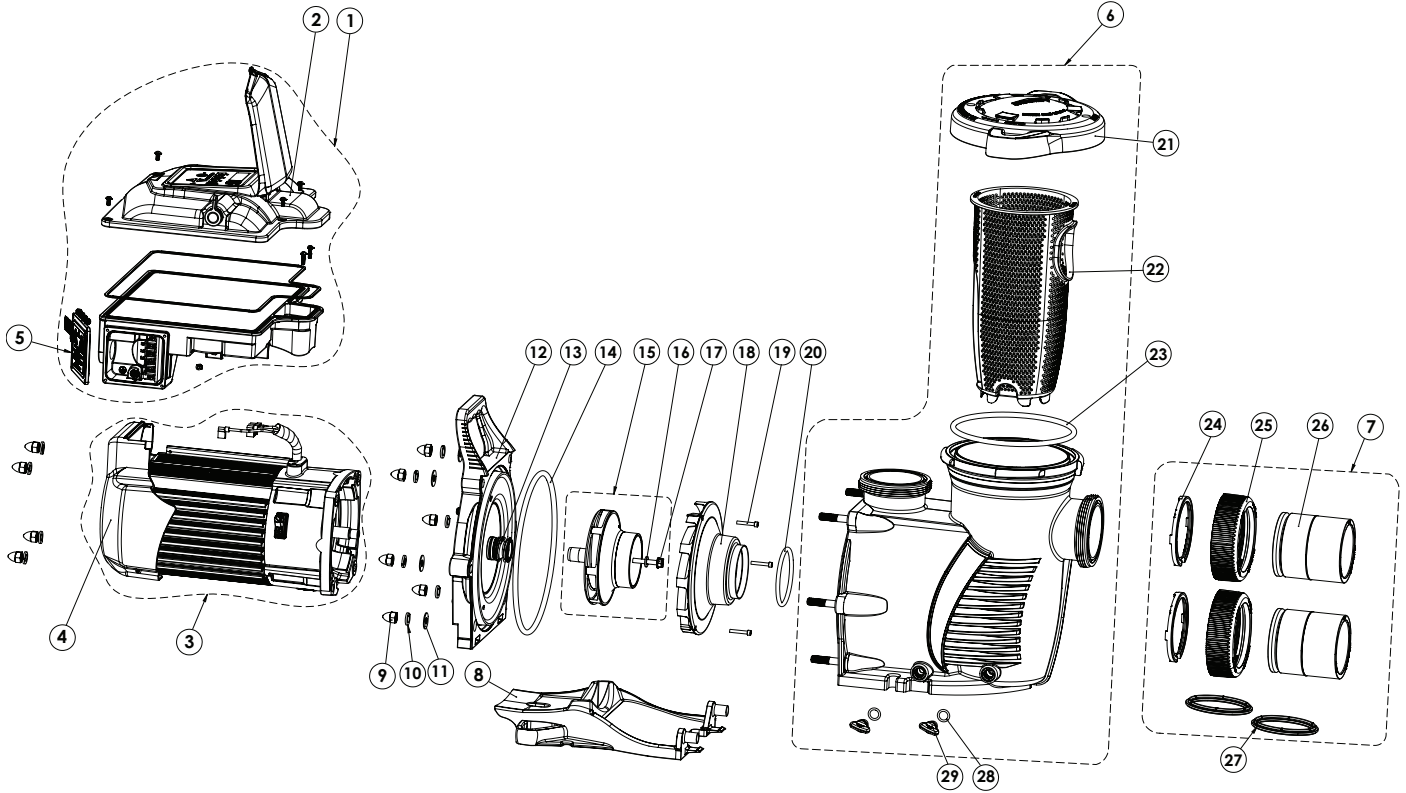

Item	Description	WhisperFloXF Part #	Max-E-ProXF Part #
1	Drive Kit	358085	358086
2	Top Cover Kit w/ Screws and Gasket	358093	358094
3	Motor w/ Fan Shroud	358089	358090
4	Fan Shroud w/ Screws	358095	358096
5	Field Wiring Cover w/ Screws	358091	358092
6	Strainer Pot Assembly	400000	401000
7	Union Kit	410020	
8	Motor Base	400004Z	401004Z
9	Acorn Nut (Qty. 10)	071413	
10	Lock Washer (Qty. 10)	U43-12SS	
11	Flat Washer (Qty. 6)	072184	
12	Seal Plate	400002	401002
13	Shaft Seal	17351-0101S	
14	Seal Plate O-ring	351446	
15	Impeller Assembly	400023Z	
16	Impeller Screw Washer	072172	
17	Impeller Screw, Plastic-Head (pumps mfg. before 10/7/19)	37337-6080	
	Impeller Screw, Metal-Head (pumps mfg. after 10/7/19)	356073	

Item	Description	WhisperFloXF Part #	Max-E-ProXF Part #
18	Diffuser	400011	
19	Diffuser Screws	353323	
20	Diffuser O-ring	350336	
21	Strainer Pot Lid	400006	401006
22	Strainer Basket	400007Z	
23	Lid O-ring	35505-1440	
24	Union C-clip (Qty. 2)	410001	
25	Union Nut (Qty. 2)	411000	
26	Union Adapter w/o Tap (Qty. 2)	410002	
27	Diamond Seal Kit (Qty. 2)	410016Z	
28	Drain Plug O-ring (Qty. 2)	192115	
29	Drain Plug (Qty. 2)	071131	357161
-	RS-485 Automation Wiring Kit, Black, 25 ft.	356324Z	
-	Digital Input Wiring Kit, Almond, 25 ft.	353129Z	
-	3-inch Flowmeter Kit	97014-4203KIT	
-	Seal Plate Hardware and O-ring Kit*	400030Z	
-	Riser Plate, XF to Challenger	400012	

(-) Not Shown

(\*) Hardware and O-ring Kit includes item no. 9-11 and 14.

# TECHNICAL DATA

## Performance Curves

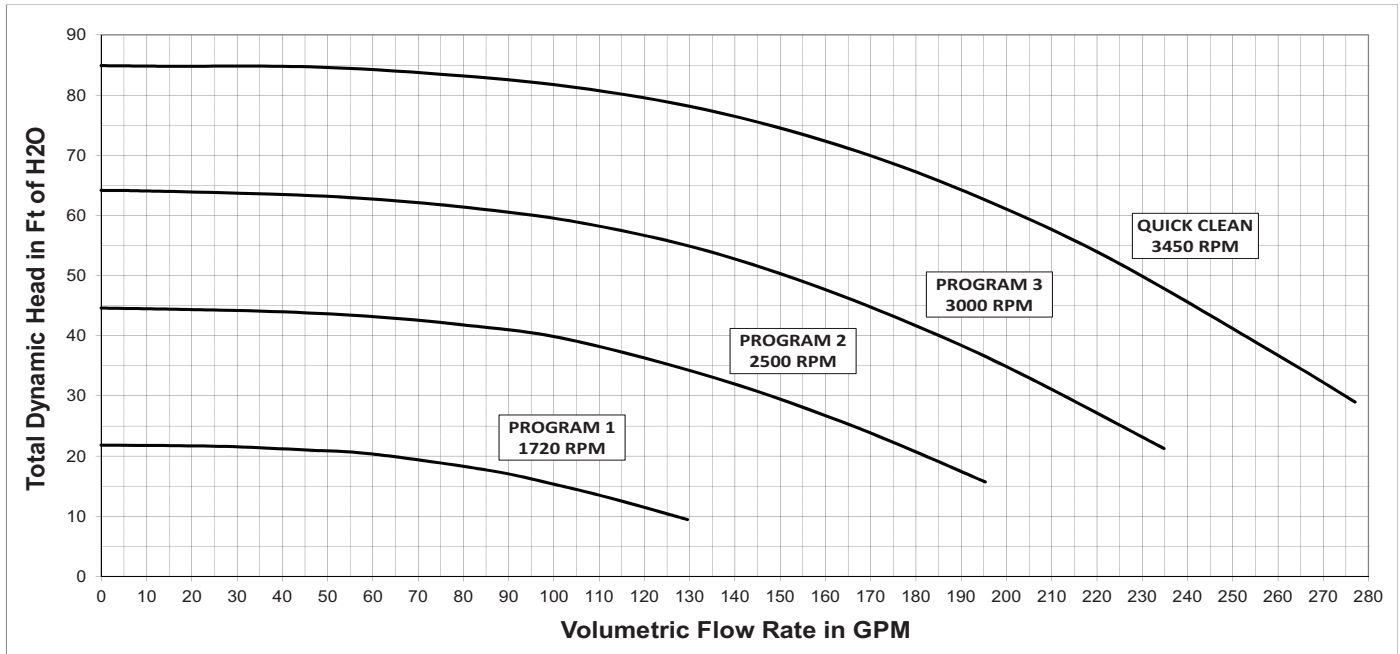

## Pump Dimensions

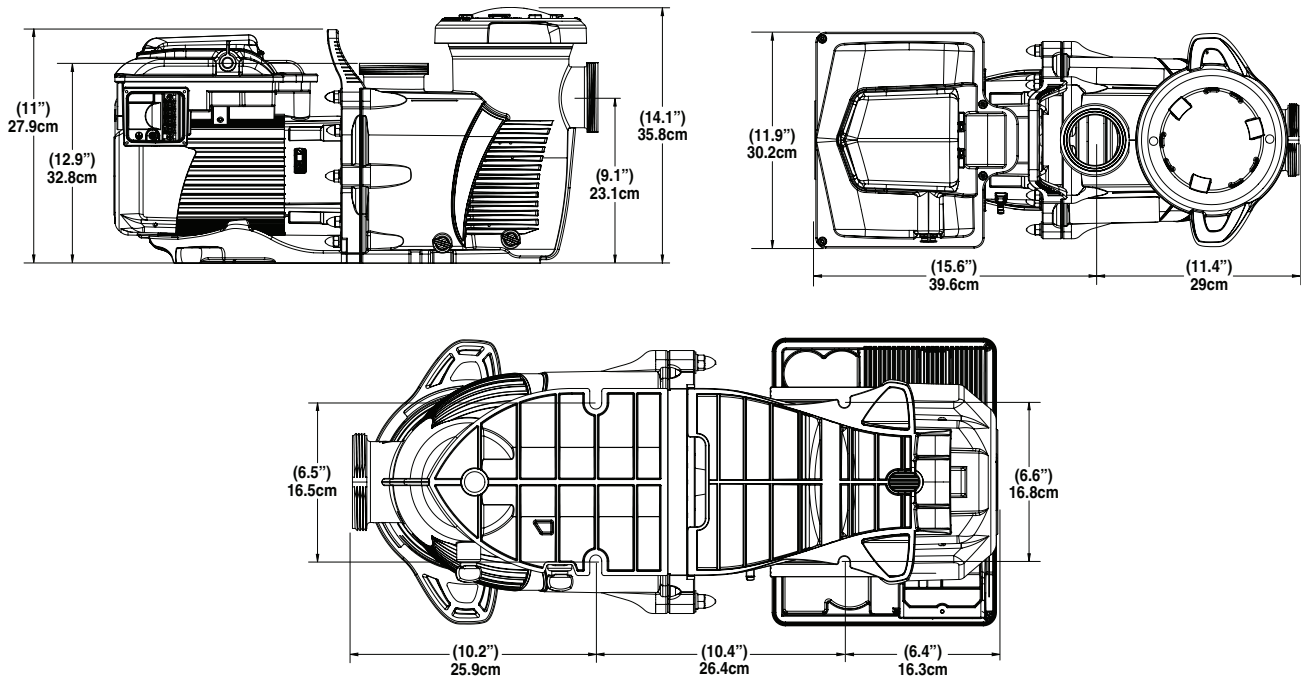

## Electrical Specifications

<b>Voltage</b>	1PH: 208-230/277-460V 3PH: 208-460V
<b>Max Amps</b>	1PH: 20-21/17-11A 3PH: 13-6A
<b>WEF / THP</b>	WEF <u>5.0</u> THP <u>5.0</u>
<b>Frequency</b>	50/60 Hz

## Mechanical Specifications

<b>Speed Range</b>	300 - 3450 RPM
<b>Maximum Continuous Load (Total HP)</b>	5
<b>Ambient Conditions</b>	<b>Storage:</b> -40°F - 185°F (-40°C - 85°C) <b>Operating:</b> 32°F - 122°F (0°C - 50°C) <b>Humidity:</b> Relative 0 to 95% non-condensing

# NOTES

---

# NOTES

---

# NOTES

---



1620 HAWKINS AVE., SANFORD, NC 27330 • (919) 566-8000  
10951 WEST LOS ANGELES AVE., MOORPARK, CA 93021 • (805) 553-5000

All indicated Pentair trademarks and logos are property of Pentair. Third party registered and unregistered trademarks and logos are the property of their respective owners.

© 2022 Pentair. All rights reserved. [WWW.PENTAIR.COM](http://WWW.PENTAIR.COM)



P/N 358077 REV. D 10/12/22