

RAIN MASTER® EAGLE™ PLUS 2-WIRE

Unlike other two-wire systems, the Rain Master® 2-wire protocol provides a two-way communication link between the controller, decoders and valves.

This provides the means for testing and diagnostic capabilities within the 2-wire system. The simplicity of the 2-wire field installation, coupled with the enhanced capability of the Rain Master Twice controllers, sets a new precedent for 2-wire control within the irrigation industry.



MODULES

- Easy-to-read LED status indication for every command
- LED also displays valve activation and diagnostic reporting
- Troubleshooting capabilities:
 - LED decoder "active" indication
 - LED valve power "on" indication
 - Two-way communication verification

DECODERS

- Each decoder has a unique address (programmable at the interface module)
- Decoders will automatically shut off if communication is lost
- Wire fault detection automatically shuts down any valve
- Valves can be operated up to 100' radius of the decoder

MODELS

Model	Description
EGP-TW	EGP in painted wall mount
EGP-TW-S	EGP in stainless steel wall mount
EGP-TW-SPED	EGP in stainless steel 14 gauge pedestal
EGP-TW-PSB	EGP in stainless steel 16 gauge VIT strong box

2-WIRE DECODERS AND ACCESSORIES

Model	Description
TW-D-1	Single valve AC decoder
TW-D-2	Dual valve AC decoder
TW-D-4	Quad valve AC decoder
TW-LA-1	Lightning arrestor (every 600 feet)
TW-SPLICE-14	14-gauge water-tight connectors
TW-CAB-14	14-gauge (red/black) Polycoated (blue) wire

LOOP CONFIGURATION

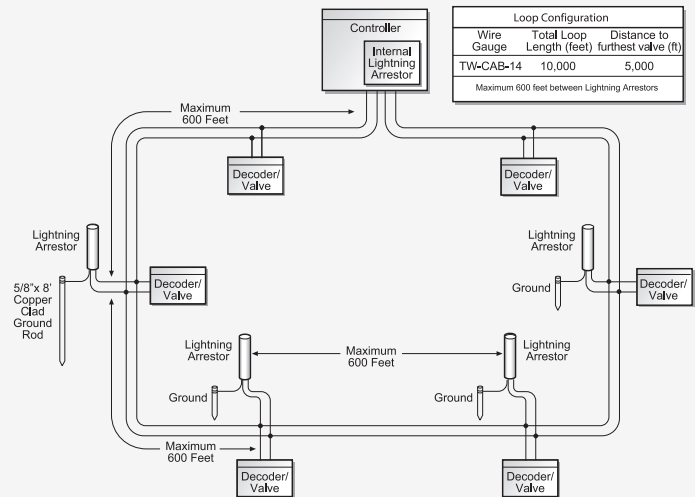

STRAIGHT LINE CONFIGURATION

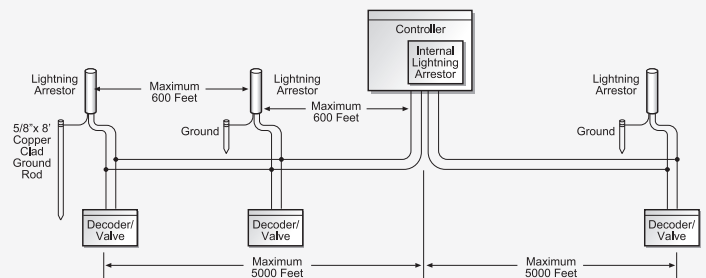

Wire Gauge	Total Wire Length (feet)
TW-CAB-14	5,000

Maximum 600 feet between Lightning Arrestors

WIRE CONNECTION DETAIL

