



*Tilted Disc® Check Valves*



# VAL-MATIC®



## Dual Disc® Check Valves



UL Listed/FM Approved  
NSF/ANSI 61 & 372 Certified

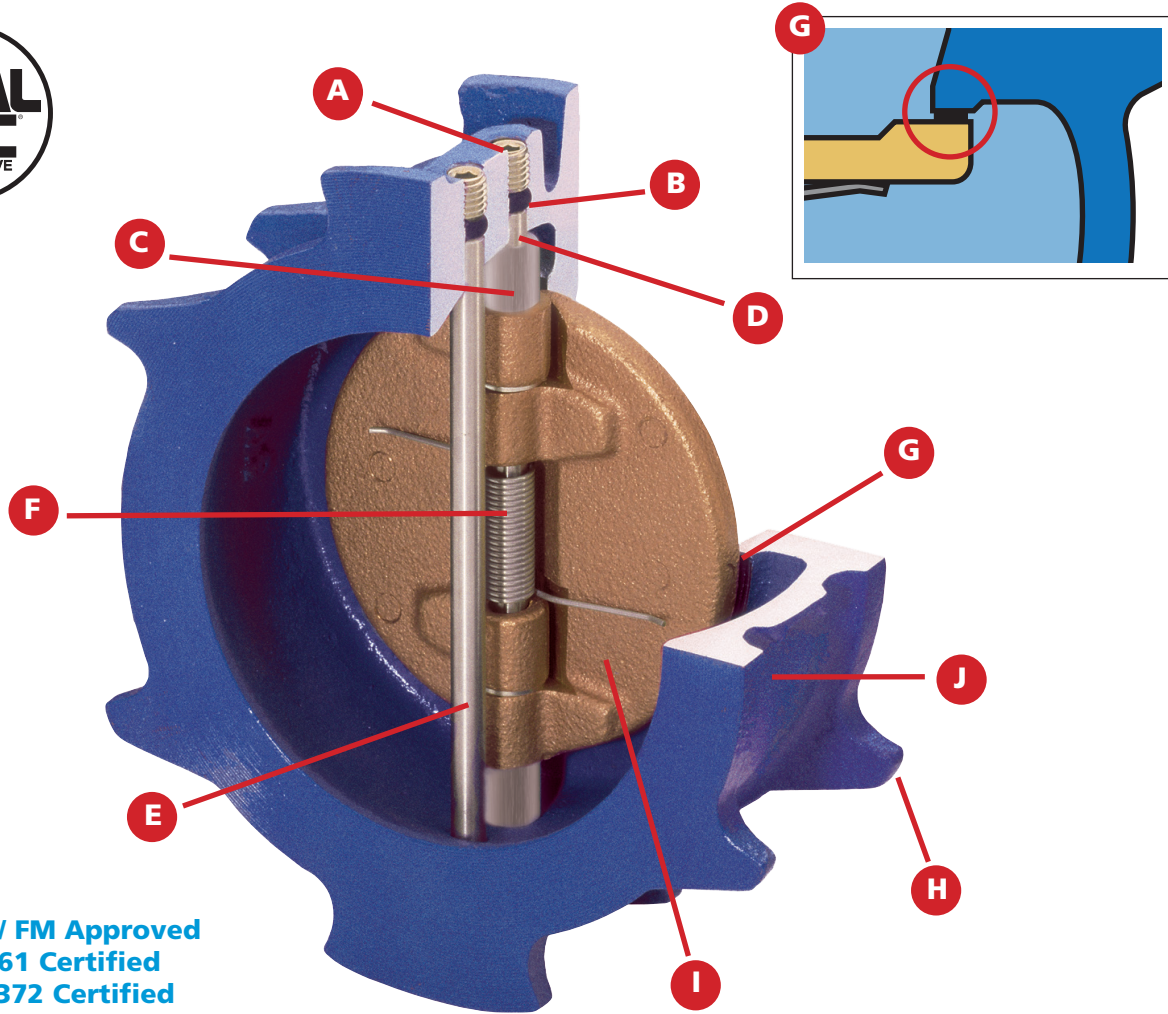

- \* UL Listed / FM Approved
- \* NSF/ANSI 61 Certified
- \* NSF/ANSI 372 Certified

### A. Retainer Plugs

Retains hinge and stop pins while providing compression to stabilization spheres.

### B. Stabilization Spheres

Stabilizes hinge and stop pins, preventing vibration and wear.

### C. Thrust Bearings

Reduces friction and wear during disc action.

### D. Hinge Pin

Heavy duty construction with increased bearing surface and strength.

### E. Stop Pin

Positions and stabilizes discs in full open position to prevent disc flutter.

### F. Spring

Specially designed torsion spring closes discs upon pump shutdown minimizing water hammer normally associated with valve shutoff. Also provides for Lift and Pivot disc action. Cycle tested 50,000 cycles to assure long, trouble free life.

### G. Vulcanized Seat

Pressure sensitive seating with full disc overlap provides positive seating at high and low pressures.

### H. Alignment Lugs

Provides for precise alignment in ANSI 125 and ISO PN10 and PN16 installations.

### I. Disc

Dual Disc design increases valve sensitivity to flow, allowing discs to close quickly on pump shutdown.

### J. Body

Choose between compact wafer design to minimize space requirements (pictured) or grooved end for ease of installation. Both provide low initial installation cost and minimal maintenance. Compact wafer style reduces installation time, minimizes space required for installation, and results in low initial unit cost. Lug style available, contact factory.

## Specifiable Features

With today's demanding system requirements, engineers must specify piping components that are both cost efficient and reliable. The design of the Val-Matic Dual Disc® Check Valve answers those needs by incorporating many unique characteristics not found in similar check valves. 2" - 12" (50-300mm) valves include ductile iron construction, with a 250 psi (17.2 BAR), cold working pressure rating. They are UL listed, FM approved and available in Wafer (ANSI 125, ISO PN10, ISO PN16) and Grooved End IPS connections. Sizes 14" (350mm) and larger are available in cast and ductile iron.

## Installation Cost

Choose between compact wafer design to minimize space requirements or grooved end for ease of installation. Both provide low initial installation cost and minimal maintenance for horizontal or vertical flow up installations. The following quality features you expect from Val-Matic can be found in both the wafer and grooved end valves.

## Operating Cost

Careful attention to inlet contouring and streamlined flow design, combined with an optimal flow area, results in low pressure loss characteristics. The resulting low power consumption translates into dollar savings throughout the long life of the valve.

## Product Reliability

Design features such as Lift and Pivot Disc Action, Stabilization Spheres, Pressure Sensitive Seating, Disc Stabilization, Disc Seal Overlap and Flow Sensitive Closure, combined with careful selection of materials of construction, reflect Val-Matic's efforts to build a quality valve. These efforts result in a Cost Efficient and Reliable product that will provide many years of trouble free service.

## Lift and Pivot Disc Action

This feature, designed to provide longer valve life, is activated during the opening and closing cycles. It works by a combination of clearance between the pivot pin and disc bores, and the placement of the legs of the torsion spring. With this design the disc will always lift first at the pivot on opening, and not return until the disc is closed, preventing wear between disc and seat surfaces.

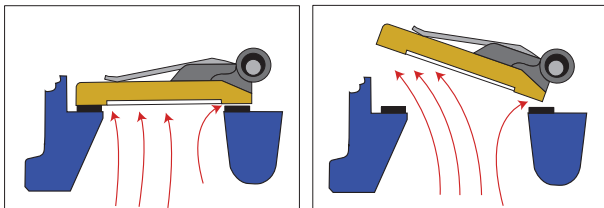

## Stabilization Spheres

The resilient, synthetic spheres inserted into the hinge and stop pin holes are compressed against the pins and effectively stabilize them during flow conditions, eliminating vibration and wear.

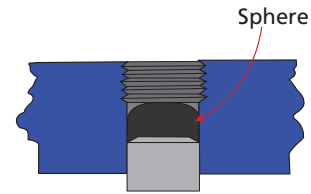

## Pressure Sensitive Seating

This design provides for minimum disc-to-seat contact at low pressures, and maximum contact at high pressures resulting in positive seating under all conditions.

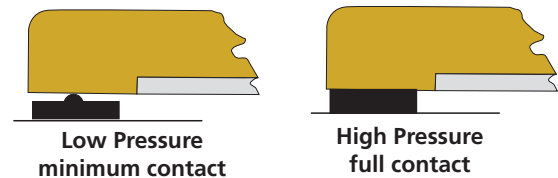

## Disc Stabilization

When the valve is fully open, the discs are positioned on a slight angle, causing the flow velocity to force the discs firmly against the stop pin. The ensuing vector forces act to stabilize the disc during flow conditions thereby preventing excessive wear due to disc "flutter."

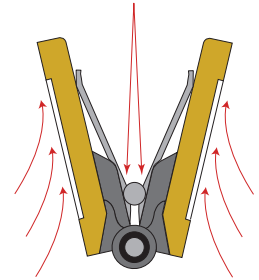

## Disc Seal Overlap

Contact between the seal and the disc is uniquely designed to eliminate indentation ridges found in designs which do not allow the disc to fully overlap the seal. Indentation ridges caused by valve designs with discs smaller in diameter than the seal can result in valve leakage.

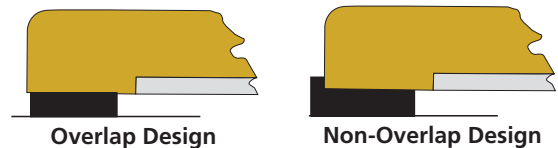

## Flow Sensitive Closure

The torsion spring closes the valve when the flow is reduced, preventing flow reversal and lessening the potential for water hammer normally associated with conventional swing check valves.

## Ratings/Construction

### PRESSURE RATINGS

MAXIMUM NON-SHOCK WORKING PRESSURE RATINGS, PSIG			
Temp. F	Ductile Iron	Cast Iron	
	2"-12"	14"-24"	30"-60"
150	250	150	150
200	235	135	115
250	220	125	85
Hydro Test*	500	230	230

MAXIMUM NON-SHOCK WORKING PRESSURE RATINGS, BAR			
Temp. C	Ductile Iron	Cast Iron	
	50-300 mm	350-600 mm	750-1500 mm
65	17.2	10.3	10.3
95	16.2	9.3	7.9
120	15.2	8.6	5.9
Hydro Test*	35	16	16

\*14" & 16" valves are hydro tested to 300 psi (20 bar)

### MATERIALS OF CONSTRUCTION

COMPONENT	STANDARD	OPTIONAL
Body 2" - 12" (50-300 mm)	Ductile Iron ASTM A536, Grade 65-45-12	-
Body 14" - 60" (350-1500 mm)	Cast Iron ASTM A126, Class B	Ductile Iron ASTM A536, Grade 65-45-12
Disc 2" - 12" (50-300 mm)	Bronze ASTM B584, C87600	-
Disc 14" - 60" (350-1500 mm)	Aluminum Bronze ASTM B148, C95200	Ductile Iron ASTM A536, Grade 65-45-12 Electroless Nickel Plating, Stainless Steel ASTM A351 Grade CF8M
Seat	Buna-N	Viton
Spring 2" - 16" (50-400mm)	T316 Stainless Steel, ASTM A313	Inconel X750
Spring 18" - 60" (450-1500mm)	17-7PH Stainless Steel, ASTM A313	Inconel X750
Coatings	Universal Primer	Fusion Bonded Epoxy

Contact Factory for other materials.

## Headloss Chart

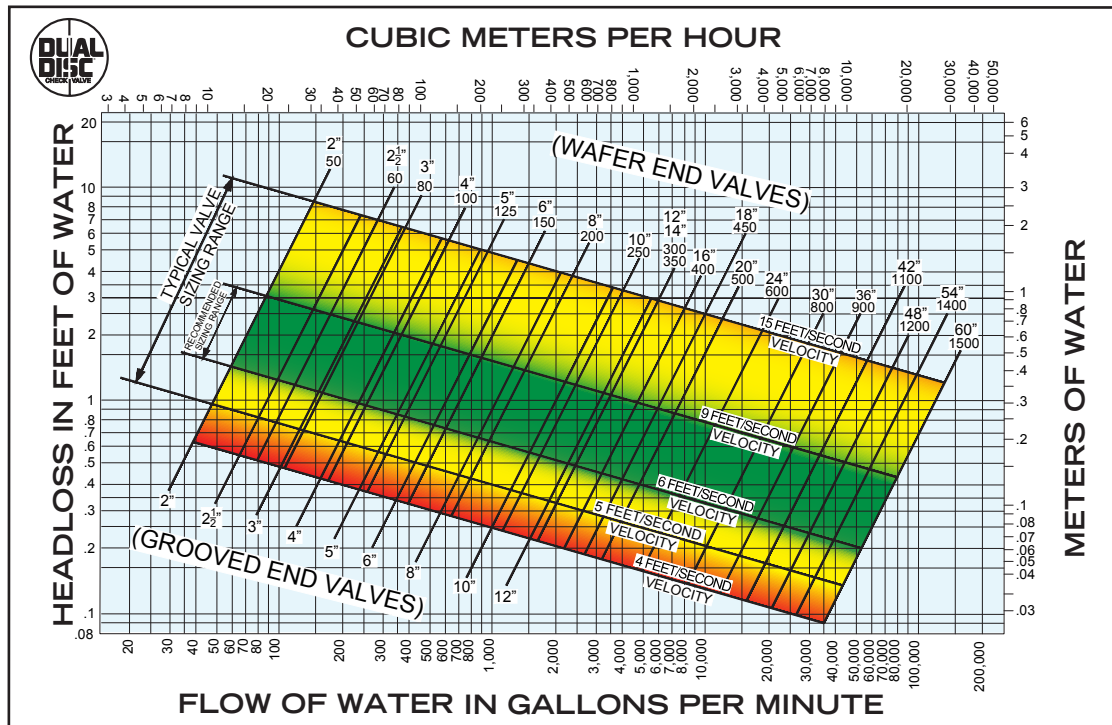

### Flow Coefficients

Size	2	2 1/2	3	4	5	6	8	10	12	14	16	18	20	24	30	36	42	48	54	60
Cv 8800G	77	129	209	358	573	898	1740	3180	4950	-	-	-	-	-	-	-	-	-	-	-
Cv 8800W	76	161	224	400	648	1060	1890	3340	5270	5200	7200	9400	12000	18500	33000	50000	72000	97000	130000	180000

## Installation Dimensions

### Wafer Style

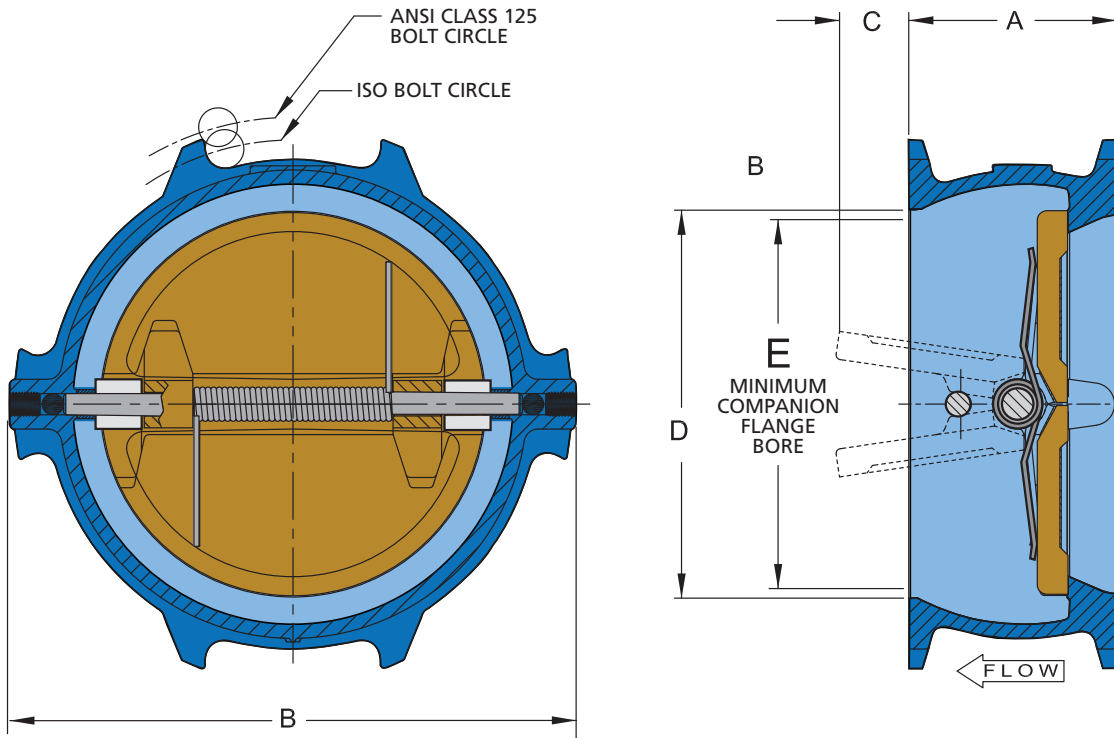

Dual Disc®  
Check Valves

**Dimensions in Inches**

Valve Size (in)	Valve Size (mm)	A	B	C	D	E	Wafer Wt. (lb)
2	50	2.13	5.13	-	2.88	-	4
2 1/2	60	2.38	6.00	0.13	3.50	1.31	5
3	80	2.63	5.63	0.18	3.88	1.69	7
4	100	2.63	7.75	0.63	4.75	3.06	9
5	125	3.25	7.56	0.81	5.50	3.63	13
6	150	3.75	8.63	0.81	6.25	4.25	19
8	200	5.00	12.25	1.00	8.00	5.50	41
10	250	5.50	14.75	2.06	10.25	8.50	65
12	300	7.12	17.38	1.94	12.00	9.25	94
14	350	7.25	17.75	3.25	14.38	12.50	187
16	400	7.50	20.25	4.50	16.38	15.00	270
18	450	8.00	21.63	5.38	18.38	17.00	330
20	500	8.38	23.88	6.38	20.25	19.00	424
24	600	8.75	28.25	8.50	24.25	23.00	589
30	800	12.00	34.75	9.50	30.00	28.50	1112
36	900	14.50	41.25	12.00	36.00	34.50	1864
42	1050	17.00	48.00	13.75	42.00	40.50	2889
48	1200	20.62	54.50	17.00	48.00	46.50	5525
54	1350	21.25	60.50	18.25	54.00	49.25	7000
60	1500	26.00	67.00	18.25	60.00	53.50	8500

## Installation Dimensions

### Grooved End Style

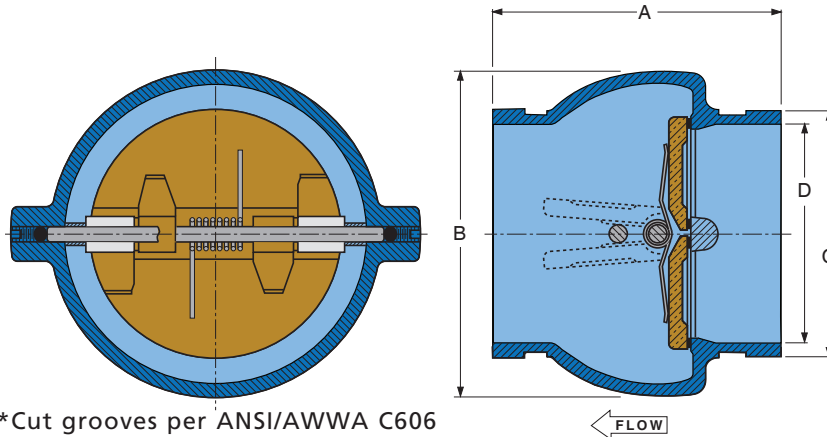

Dimensions in Inches						
Valve Size (in)	Valve Size (mm)	A	B	C	D	Grooved Wt. (lb)
2	50	4.66	4.12	2.38	2.00	4
2 1/2	60	4.90	4.88	2.88	2.41	5
3	80	5.31	5.38	3.50	2.94	8
4	100	5.38	6.00	4.50	3.91	9
5	125	5.72	7.06	5.56	4.89	13
6	150	6.00	8.12	6.62	5.92	18
8	200	6.72	10.03	8.62	7.91	30
10	250	7.78	12.38	10.75	10.00	56
12	300	8.18	14.38	12.75	11.94	87

### Lug Style

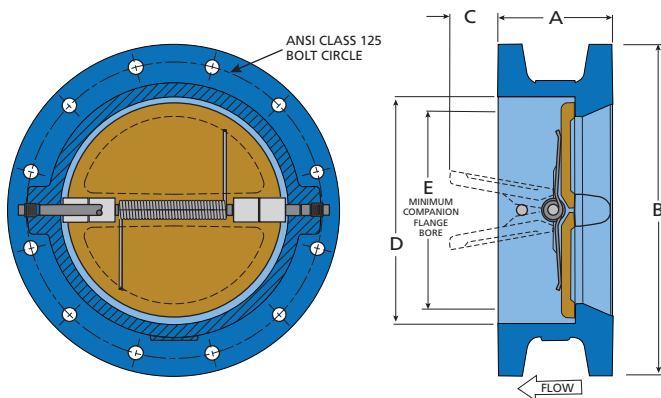

Dimensions in Inches						
Valve Size (in)	Valve Size (mm)	A	B	C	D	E
14	350	7.25	21.00	3.25	14.38	12.50
16	400	7.50	23.50	4.50	16.38	15.00
18	450	8.00	25.00	5.38	18.38	17.00
20	500	8.38	27.50	6.38	20.25	19.00
24	600	8.75	32.00	8.50	24.25	23.00
30	800	12.00	38.75	9.50	30.00	28.50
36	900	14.50	46.00	12.00	36.00	34.50
42	1050	17.00	53.00	13.75	42.00	40.50
48	1200	20.62	59.50	17.00	48.00	46.50
54	1350	21.25	66.25	18.25	54.00	49.50
60	1500	26.00	73.00	18.25	60.00	53.50

## SCOPE

- 1.1 This specification covers the design, manufacture, and testing of 2 in. (50 mm) through 60 in. (1500 mm) Dual Disc Check Valves suitable for pressures up to 500 psig (3450 kPa) water service.
- 1.2 The Check Valve shall be of the dual disc, wafer style, or grooved end with torsion spring induced closure.

## STANDARDS AND APPROVALS

- 2.1 The valves shall be designed, manufactured and tested in accordance with American Water Works Association Standard ANSI/AWWA C518.
- 2.2 The valves for use in fire protection systems shall be Underwriters Laboratories listed in sizes 2 1/2 in.-12 in. and Factory Mutual approved in sizes in sizes 2 1/2 in.-16 in.
- 2.3 The valves shall be certified to be Lead-Free in accordance with NSF/ANSI 372.
- 2.4 Manufacturer shall have a quality management system that is certified to ISO 9001 by an accredited, certifying body.

## CONNECTIONS

- 3.1 Wafer style valves shall be provided in sizes 2 in. (50 mm) through 12 in. (300 mm) for installation between ANSI B16.1 Class 125 iron flanges, or between ISO 7005-2 PN10 or PN16 flanges.
- 3.2 Wafer style valves shall be provided in sizes 14 in. (350 mm) through 66 in. (1650 mm) for installation between ANSI B16.1 Class 125 or Class 250 iron flanges.
- 3.3 Grooved end valves shall be provided in 2 in. (50mm) through 12 in. (300mm) for installation on pipe with cut grooves per ANSI/AWWA C606 for steel IPS pipe.

## DESIGN

- 4.1 The body shall be of one piece construction incorporating a vulcanized synthetic seal.
- 4.2 Seal design shall include a raised sealing bead for positive seating at both high and low pressures. The disc shall fully overlap the synthetic seal, preventing pressure indentations.
- 4.3 Opening and closing of the valve shall utilize a lift and pivot action to prevent seal wear and ensure long seal life.
- 4.4 Disc stabilization in the full open position shall be provided by the use of a stop pin.
- 4.5 The stop and hinge pins shall be stabilized by the use of synthetic spheres to prevent wear due to vibration during operating conditions. The design shall incorporate a raised seat and 1/2 in. body wall to disc clearance to ensure proper operation after long periods of inactivity and potential corrosion buildup.
- 4.6 Closure shall be assisted with a torsion spring to provide a cracking pressure of 0.25 psig.

## MATERIALS

- 5.1 The valve body on sizes 2-12 in. shall be constructed of ASTM A536 Grade 65-45-12 ductile iron. On sizes 14-66 in. the valve body shall be constructed of ASTM A126 Class B cast iron for Class 125 and Class 250 valves.
- 5.2 For sized 2-12 in. the disc shall be constructed of ASTM B584, Alloy C87600 (2-12 in.) cast bronze. For sizes 14 in. and up, the disc shall be constructed of ASTM B148, Alloy C95200 cast aluminum bronze.
- 5.3 The hinge pins and stop pins shall be Type 316 stainless steel.
- 5.4 The torsion spring shall be ASTM A313 Type 316 stainless steel up to 16 in. (400 mm) and ASTM A313 Type 17-7 PH on 18 in. (450 mm) and larger sizes.
- 5.5 The seal shall be Buna-N per ASTM D2000-BG.

## OPTIONS

- 6.1 Optional Disc materials for sizes 14 in. and up include ASTM A536 Grade 65-45-12 ductile iron with electroless nickel plating and ASTM A351 Grade CF8M stainless steel.
- 6.2 Air Service Spring (Series 8900W)
- 6.3 Optional Spring material includes Inconel X750.
- 6.4 For 14 in. and larger, end connections shall be lug with threaded flange lugs or full diameter threaded flanges when specified for end of line service.
- 6.5 Valve interiors and exteriors shall be coated with an NSF/ANSI 61 certified fusion bonded epoxy in accordance with AWWA C550 when specified.

## MANUFACTURE

- 7.1 The valves shall be hydrostatically tested at 1.5 or 2 times their rated cold working pressure. A seat closure test at 1.5 or 2 times the valve rating shall be conducted to demonstrate zero leakage. Additional tests shall be conducted per AWWA, ANSI, MSS or API standards when specified. When requested, the manufacturer shall provide test certificates, dimensional drawings, parts list drawings, and operation and maintenance manuals.
- 7.2 The exterior of the valve shall be coated with a universal alkyd primer.
- 7.3 Dual Disc® Check Valves shall be Series #8800W (Wafer Style), Series #8800G (Grooved End), Series #8800 (Class 125), #8700 (Class 250), or #8800L (Lug) as manufactured by Val-Matic® Valve & Mfg. Corporation, Elmhurst, IL. USA or approved equal.