

SVL56

OWNER'S MANUAL



SAVE THESE INSTRUCTIONS • READ ALL INSTRUCTIONS PRIOR TO INSTALLATION

IMPORTANT: FOLLOW ALL NATIONAL AND LOCAL BUILDING AND SAFETY CODES



Waterway™

2200 East Sturgis Road, Oxnard CA 93030 • Phone 805.981.0262 • Fax 805.981.9403

www.waterwayplastics.com • waterway@waterwayplastics.com

SAFETY

 **WARNING:** Risk of electrical shock. Connect only to a Ground Fault Circuit Interrupter (GFCI). Do not use extension cords. Contact a qualified electrician to provide a properly located GFCI outlet if not available.

1. If installed within an outer enclosure or spa / hot tub skirt, provide for adequate ventilation and air circulation to prevent overheating of motor.
2. Properly secure to ground pad.

 **WARNING:** To reduce the risk of injury, do not permit children to use this product unless closely supervised at all times.

GENERAL TIPS AND GUIDELINES

Locate the pump as close to pool as practical and run suction line as direct as possible. This cuts down on friction loss through pipe and fittings. Never overtighten pipe connections. Use only pipe sealants formulated specifically for plastics (Teflon tape, Permatex No. 2, etc.). Suction line should have continuous slope from lowest point in line. Make sure suction joints are tight. Suction pipe should be as large or larger than discharge pipe. Damp, nonventilated locations should be avoided. Motors require free circulation of air to aid in cooling. Insure that the electrical supply available is compatible with the motor's voltage, phase and cycle, and that wire size is adequate for the HP rating and distance from power source. Motor must always be properly grounded. If cord is connected, use only a properly grounded outlet. Electrical circuits must be protected by proper size Ground Fault Circuit Interrupter (GFCI) as required by applicable electrical codes. All electrical wiring must be performed by qualified personnel, and must conform to local codes and regulations.

MAINTENANCE

1. Clean strainer basket regularly. Do not strike basket to clean. Inspect strainer, lid, and o-ring regularly and replace as necessary.
2. Waterway pumps have self-lubricating motor bearings and shaft seals. No lubrication is necessary.
3. **POSSIBLE FIRE HAZARD!** Keep motor clean. Insure air vents are free from obstruction (grass, dry leaves, etc.).
4. Occasionally, shaft seals become damaged or worn and must be replaced. See Seal Changing instructions.

WINTERIZATION

1. Drain pump by removing drain plug(s) and store in strainer basket.
2. Disconnect electrical wires and protect pump assembly from the elements by covering. Or, you may choose to disconnect electrical wires and pipe connections, and store pump in a dry, well-ventilated room.
NOTE: Before reactivating pump, relubricate o-rings and thoroughly clean and remove scale, dirt, etc.

SEAL CHANGING

 **EXERCISE EXTREME CARE IN HANDLING AND INSTALLING THE NEW SEAL AND FACE PLATE. THE SURFACES OF THE CERAMIC SEAL (IN THE IMPELLER) MAY EASILY BE DAMAGED BY DIRT OR SCRATCHING!**

 **WARNING:** Turn off power before servicing.

1. Stop water flow to and from pump. Drain pump by removing drain plugs.
2. Remove the eight (8) 3/8" x 1 3/4" hex head bolts which hold the face plate to the volute.
3. Slide the motor assembly out from the volute, exposing the diffuser. Unscrew 3/32" Allenhead screws and pop out diffuser, exposing the impeller wear ring. The wear ring should fit snugly on the impeller. If not, replace it.
4. Remove the motor shaft end cover by prying with flathead screwdriver.
5. To prevent motor shaft from turning, carefully slide a 7/16" wrench between the capacitor and the protector switch, and rotate the impeller so the wrench fits over the (2) flats on the motor shaft.
6. Rotate the impeller counterclockwise and remove. The spring portion of the seal assembly is now exposed.
NOTE: Carefully position the spring seal, and remove it.
NOTE: Replace motor cover to protect delicate motor parts.
7. Remove the face plate.
NOTE: The "U" shape on the end of the diffuser should be upside-down when this part is reinstalled.
8. Clean all recesses and parts to be reassembled. Inspect o-ring and replace if necessary.
9. Clean the impeller hub and pump housing seal recess with a diluted solution on nongranular liquid-type soap. The use of petroleum or silicone lubricants may contribute to seal leakage.
10. Gently wipe the black, polished surface of the spring seal assembly with a soft cotton cloth. Place onto the impeller hub with the black polished surface facing away from the impeller.
11. Gently wipe the polished face of the ceramic seat with a soft cotton cloth. Lubricate the o-ring on the ceramic seat and press it firmly and evenly into the recess of the seal plate polished side facing out.
12. Screw the impeller onto the motor shaft in a clockwise direction. Tighten snugly by holding motor shaft with wrench.
13. Make sure the wear ring is correctly placed on the impeller. Place the diffuser over the impeller onto the face plate.
NOTE: The "U" shape on the end of the diffuser should be upside-down.
14. Slide the motor assembly, with the diffuser in place, into the volute (wet end), being careful not to dislodge the diffuser's o-ring.
15. Fasten assembly to housing using the eight (8) 3/8" x 1 3/4" bolts (making sure volute o-ring is in place). Tighten bolts alternately so as to distribute the torque evenly (for example, tighten the top right, the bottom left, then 2nd from bottom left, then 2nd from top right, and so on).

ELECTRICAL GUIDE

MOTOR HP	VOLTS	CIRCUIT BREAKING RATING (AMPS)	BRANCH FUSETRON RATING (AMPS)	RECOMMENDED WIRE SIZE 0-50'
1	115/230	30/15	30/15	No. 10/14
1 ½	115/230	30/15	30/15	No. 10/14
2	230	20	20	No. 12
3	230	20	20	No. 12

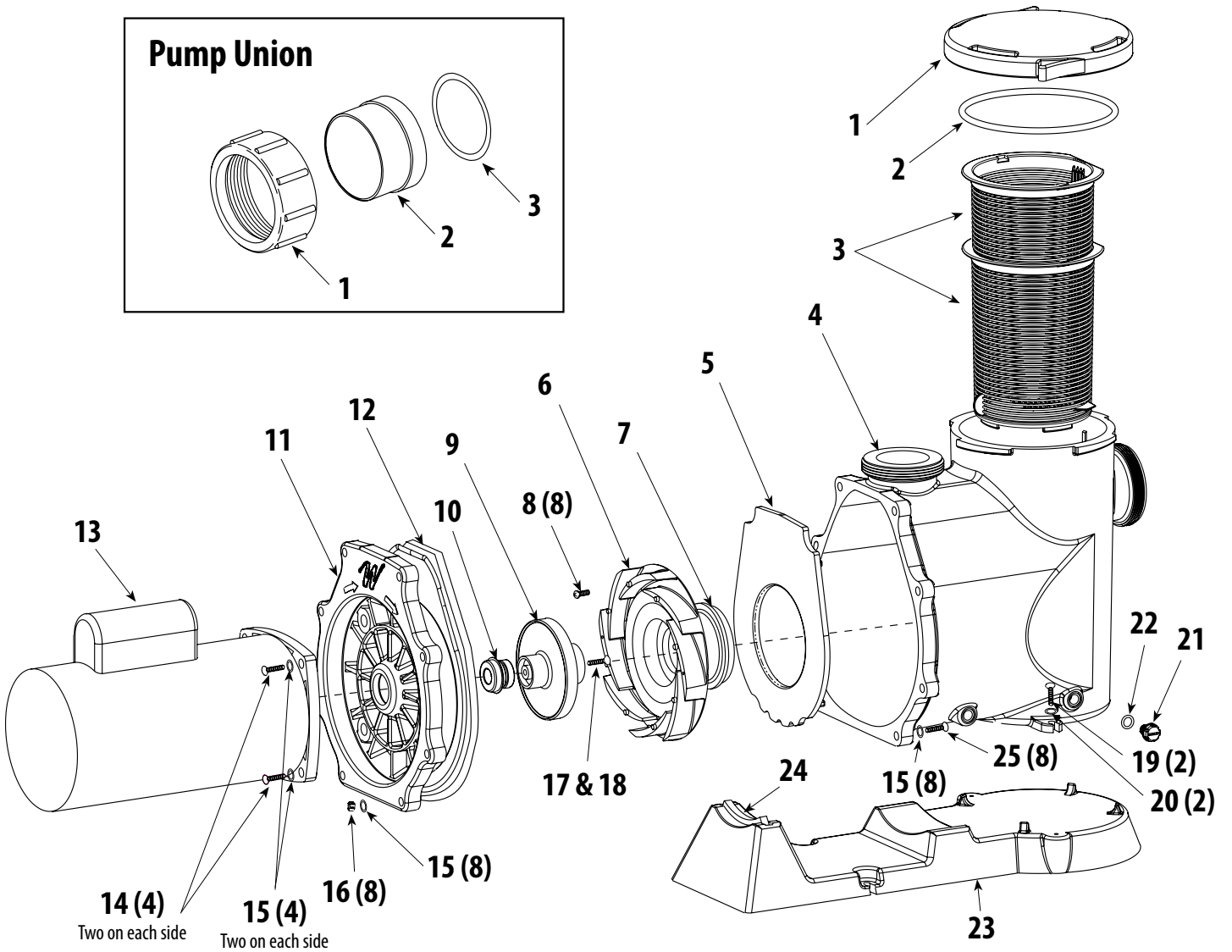
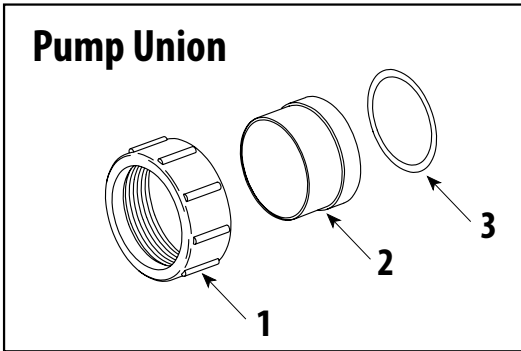

SVL56 PUMP REPLACEMENT PARTS

<i>Item</i>	<i>Part No.</i>	<i>Description</i>	<i>Item</i>	<i>Part No.</i>	<i>Description</i>
1	511-1310	Lid	13	3510440	SVL56E-110 Motor
2	805-0439	Lid O-Ring		3510670	SVL56E-115 Motor
3	319-1310	Basket Assembly		3510850	SVL56E-120 Motor
4	315-1300	Housing		3511450	SVL56E-130 Motor
5	319-1260	Diffuser Plate - High-Pressure <i>(no plate used in High-Flow)</i>		3510331	SVL56S-107 Motor
6	310-3300	Diffuser - High-Flow		3510431	SVL56S-110 Motor
	310-7470	Diffuser - High-Pressure		3510631	SVL56S-115 Motor
7	805-0238	Diffuser O-Ring		3510821	SVL56S-120 Motor
8	819-0018	Diffuser Screw		3511031	SVL56S-125 Motor
9	310-3650	SVL56E-110 Impeller Assembly - High-Flow		3520450	SVL56S-210 Motor
	310-3660	SVL56E-115 Impeller Assembly - High-Flow		3520650	SVL56S-215 Motor
	310-3670	SVL56E-120 Impeller Assembly - High-Flow		3520850	SVL56S-220 Motor
	310-3680	SVL56E-130 Impeller Assembly - High-Flow	14	819-0011	Screw - 3/8" - 16 x 1/8" (4)
	310-3650	SVL56S-107 Impeller Assembly - High-Flow	15	820-0017	Flat Washer (12)
	310-3650	SVL56S-110 Impeller Assembly - High-Flow	16	820-0016	Hex Nut Ea.
	310-3660	SVL56S-115 Impeller Assembly - High-Flow	17	819-4360	Screw Head Left-Hand
	310-3670	SVL56S-120 Impeller Assembly - High-Flow	18	711-4300	SVL Gasket for Left Hand Screw
	310-3670	SVL56S-125 Impeller Assembly - High-Flow	19	819-0013	Screw (2) Ea.
	310-3650	SVL56S-210 Impeller Assembly - High-Flow	20	820-0018	Flat Washer (2) Ea.
	310-3660	SVL56S-215 Impeller Assembly - High-Flow	21	715-1201	Drain Plug
	310-3670	SVL56S-220 Impeller Assembly - High-Flow	22	805-0112	Drain Plug O-Ring
	310-7420	SVLHPE-110 Impeller Assembly - High-Pressure	23	672-1300	SVL56 Base
	310-7430	SVLHPE-115 Impeller Assembly - High-Pressure	24	672-1310	Motor Support
	310-7440	SVLHPE-120 Impeller Assembly - High-Pressure	25	819-0016	Screw (8)
	310-7450	SVLHPE-130 Impeller Assembly - High-Pressure			
	310-7400	SVLHPS-107 Impeller Assembly - High-Pressure			
	310-7410	SVLHPS-110 Impeller Assembly - High-Pressure			
	310-7420	SVLHPS-115 Impeller Assembly - High-Pressure			
	310-7430	SVLHPS-120 Impeller Assembly - High-Pressure			
	310-7440	SVLHPS-125 Impeller Assembly - High-Pressure			
	310-7420	SVLHPS-215 Impeller Assembly - High-Pressure			
	310-7430	SVLHPS-220 Impeller Assembly - High-Pressure			
	310-7440	SVLHPS-225 Impeller Assembly - High-Pressure			
10	319-3110B	Pump Seal Set - Viton			
11	311-1400	Faceplate			
12	711-4290	Faceplate Gasket			

PUMP UNION REPLACEMENT PARTS

1	415-4211	2 ½" Union Nut
2	417-5971	2" Tailpiece
	417-6001	2 ½" Tailpiece
3	711-6020	Gasket

PUMP UNION ASSEMBLY

400-6021B	2 ½" Union x 2 ½" Socket
400-5971B	2 ½" Union x 2" Socket

2 of each union are included with pump



Waterway™

2200 East Sturgis Road, Oxnard CA 93030 • Phone 805.981.0262 • Fax 805.981.9403

www.waterwayplastics.com • waterway@waterwayplastics.com