

SVL56 OWNER'S MANUAL



SAVE THESE INSTRUCTIONS • READ ALL INSTRUCTIONS PRIOR TO INSTALLATION

IMPORTANT: FOLLOW ALL NATIONAL AND LOCAL BUILDING AND SAFETY CODES



Waterway™

2200 East Sturgis Road, Oxnard CA 93030 • Phone 805.981.0262 • Fax 805.981.9403

www.waterwayplastics.com • waterway@waterwayplastics.com

SAFETY

 **WARNING:** Risk of electrical shock. Connect only to a Ground Fault Circuit Interrupter (GFCI). Do not use extension cords. Contact a qualified electrician to provide a properly located GFCI outlet if not available.

1. If installed within an outer enclosure or spa / hot tub skirt, provide for adequate ventilation and air circulation to prevent overheating of motor.
2. Properly secure to ground pad.

 **WARNING:** To reduce the risk of injury, do not permit children to use this product unless closely supervised at all times.

GENERAL TIPS AND GUIDELINES

Locate the pump as close to pool as practical and run suction line as direct as possible. This cuts down on friction loss through pipe and fittings. Never overtighten pipe connections. Use only pipe sealants formulated specifically for plastics (Teflon tape, Permatex No. 2, etc.). Suction line should have continuous slope from lowest point in line. Make sure suction joints are tight. Suction pipe should be as large or larger than discharge pipe. Damp, nonventilated locations should be avoided. Motors require free circulation of air to aid in cooling. Insure that the electrical supply available is compatible with the motor's voltage, phase and cycle, and that wire size is adequate for the HP rating and distance from power source. Motor must always be properly grounded. If cord is connected, use only a properly grounded outlet. Electrical circuits must be protected by proper size Ground Fault Circuit Interrupter (GFCI) as required by applicable electrical codes. All electrical wiring must be performed by qualified personnel, and must conform to local codes and regulations.

MAINTENANCE

1. Clean strainer basket regularly. Do not strike basket to clean. Inspect strainer, lid, and o-ring regularly and replace as necessary.
2. Waterway pumps have self-lubricating motor bearings and shaft seals. No lubrication is necessary.
3. **POSSIBLE FIRE HAZARD!** Keep motor clean. Insure air vents are free from obstruction (grass, dry leaves, etc.).
4. Occasionally, shaft seals become damaged or worn and must be replaced. See Seal Changing instructions.

WINTERIZATION

1. Drain pump by removing drain plug(s) and store in strainer basket.
2. Disconnect electrical wires and protect pump assembly from the elements by covering. Or, you may choose to disconnect electrical wires and pipe connections, and store pump in a dry, well-ventilated room.
NOTE: Before reactivating pump, relubricate o-rings and thoroughly clean and remove scale, dirt, etc.

SEAL CHANGING

 **EXERCISE EXTREME CARE IN HANDLING AND INSTALLING THE NEW SEAL AND FACE PLATE. THE SURFACES OF THE CERAMIC SEAL (IN THE IMPELLER) MAY EASILY BE DAMAGED BY DIRT OR SCRATCHING!**

 **WARNING:** Turn off power before servicing.

1. Stop water flow to and from pump. Drain pump by removing drain plugs.
2. Remove the eight (8) 3/8" x 1 3/4" hex head bolts which hold the face plate to the volute.
3. Slide the motor assembly out from the volute, exposing the diffuser. Unscrew 3/32" Allenhead screws and pop out diffuser, exposing the impeller wear ring. The wear ring should fit snugly on the impeller. If not, replace it.
4. Remove the motor shaft end cover by prying with flathead screwdriver.
5. To prevent motor shaft from turning, carefully slide a 7/16" wrench between the capacitor and the protector switch, and rotate the impeller so the wrench fits over the (2) flats on the motor shaft.
6. Rotate the impeller counterclockwise and remove. The spring portion of the seal assembly is now exposed.
NOTE: Carefully position the spring seal, and remove it.
NOTE: Replace motor cover to protect delicate motor parts.
7. Remove the face plate.
NOTE: The "U" shape on the end of the diffuser should be upside-down when this part is reinstalled.
8. Clean all recesses and parts to be reassembled. Inspect o-ring and replace if necessary.
9. Clean the impeller hub and pump housing seal recess with a diluted solution on nongranular liquid-type soap. The use of petroleum or silicone lubricants may contribute to seal leakage.
10. Gently wipe the black, polished surface of the spring seal assembly with a soft cotton cloth. Place onto the impeller hub with the black polished surface facing away from the impeller.
11. Gently wipe the polished face of the ceramic seat with a soft cotton cloth. Lubricate the o-ring on the ceramic seat and press it firmly and evenly into the recess of the seal plate polished side facing out.
12. Screw the impeller onto the motor shaft in a clockwise direction. Tighten snugly by holding motor shaft with wrench.
13. Make sure the wear ring is correctly placed on the impeller. Place the diffuser over the impeller onto the face plate.
NOTE: The "U" shape on the end of the diffuser should be upside-down.
14. Slide the motor assembly, with the diffuser in place, into the volute (wet end), being careful not to dislodge the diffuser's o-ring.
15. Fasten assembly to housing using the eight (8) 3/8" x 1 3/4" bolts (making sure volute o-ring is in place). Tighten bolts alternately so as to distribute the torque evenly (for example, tighten the top right, the bottom left, then 2nd from bottom left, then 2nd from top right, and so on).

ELECTRICAL GUIDE

| MOTOR HP | VOLTS | CIRCUIT BREAKING RATING (AMPS) | BRANCH FUSETRON RATING (AMPS) | RECOMMENDED WIRE SIZE 0-50' |
|----------|---------|-----------------------------------|----------------------------------|--------------------------------|
| 1 | 115/230 | 30/15 | 30/15 | No. 10/14 |
| 1½ | 115/230 | 30/15 | 30/15 | No. 10/14 |
| 2 | 230 | 20 | 20 | No. 12 |
| 3 | 230 | 20 | 20 | No. 12 |

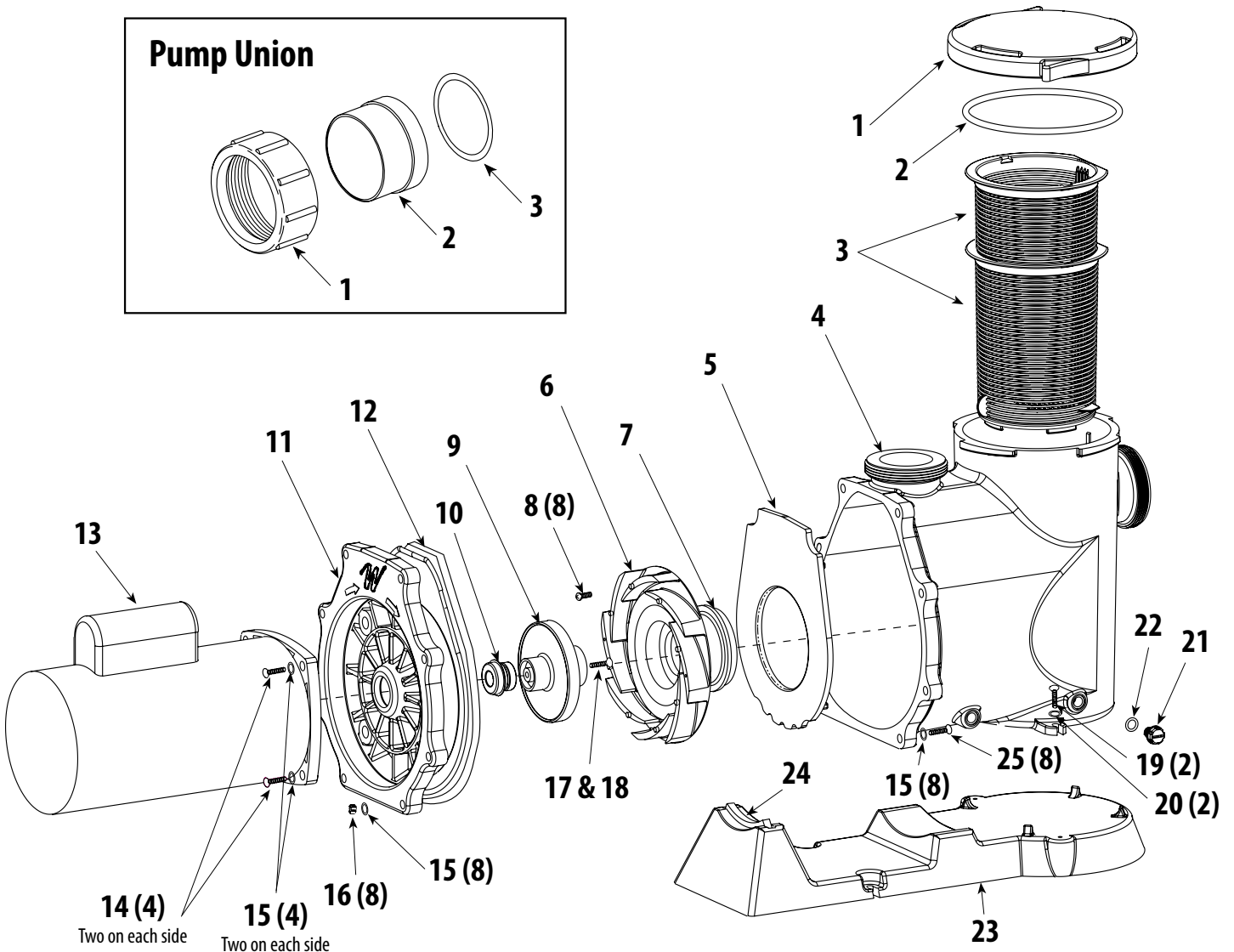
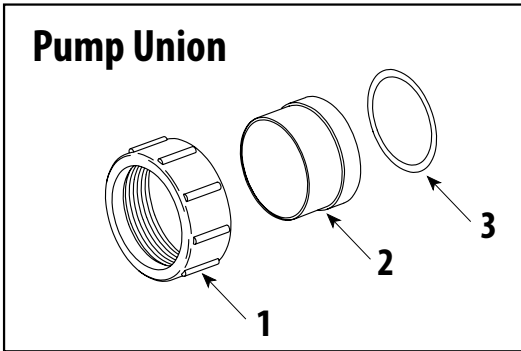

SVL56 PUMP REPLACEMENT PARTS

| <i>Item</i> | <i>Part No.</i> | <i>Description</i> | <i>Item</i> | <i>Part No.</i> | <i>Description</i> |
|-------------|------------------|--|-------------|-----------------|--------------------------------|
| 1 | 511-1310 | Lid | 13 | 3510440 | SVL56E-110 Motor |
| 2 | 805-0439 | Lid O-Ring | | 3510670 | SVL56E-115 Motor |
| 3 | 319-1310 | Basket Assembly | | 3510850 | SVL56E-120 Motor |
| 4 | 315-1300 | Housing | | 3511450 | SVL56E-130 Motor |
| 5 | 319-1260 | Diffuser Plate - High-Pressure <i>(no plate used in High-Flow)</i> | | 3510331 | SVL56S-107 Motor |
| 6 | 310-3300 | Diffuser - High-Flow | | 3510431 | SVL56S-110 Motor |
| | 310-7470 | Diffuser - High-Pressure | | 3510631 | SVL56S-115 Motor |
| 7 | 805-0238 | Diffuser O-Ring | | 3510821 | SVL56S-120 Motor |
| 8 | 819-0018 | Diffuser Screw | | 3511031 | SVL56S-125 Motor |
| 9 | 310-3650 | SVL56E-110 Impeller Assembly - High-Flow | | 3520450 | SVL56S-210 Motor |
| | 310-3660 | SVL56E-115 Impeller Assembly - High-Flow | | 3520650 | SVL56S-215 Motor |
| | 310-3670 | SVL56E-120 Impeller Assembly - High-Flow | | 3520850 | SVL56S-220 Motor |
| | 310-3680 | SVL56E-130 Impeller Assembly - High-Flow | 14 | 819-0011 | Screw - 3/8" - 16 x 1/8" (4) |
| | 310-3650 | SVL56S-107 Impeller Assembly - High-Flow | 15 | 820-0017 | Flat Washer (12) |
| | 310-3650 | SVL56S-110 Impeller Assembly - High-Flow | 16 | 820-0016 | Hex Nut Ea. |
| | 310-3660 | SVL56S-115 Impeller Assembly - High-Flow | 17 | 819-4360 | Screw Head Left-Hand |
| | 310-3670 | SVL56S-120 Impeller Assembly - High-Flow | 18 | 711-4300 | SVL Gasket for Left Hand Screw |
| | 310-3670 | SVL56S-125 Impeller Assembly - High-Flow | 19 | 819-0013 | Screw (2) Ea. |
| | 310-3650 | SVL56S-210 Impeller Assembly - High-Flow | 20 | 820-0018 | Flat Washer (2) Ea. |
| | 310-3660 | SVL56S-215 Impeller Assembly - High-Flow | 21 | 715-1201 | Drain Plug |
| | 310-3670 | SVL56S-220 Impeller Assembly - High-Flow | 22 | 805-0112 | Drain Plug O-Ring |
| | 310-7420 | SVLHPE-110 Impeller Assembly - High-Pressure | 23 | 672-1300 | SVL56 Base |
| | 310-7430 | SVLHPE-115 Impeller Assembly - High-Pressure | 24 | 672-1310 | Motor Support |
| | 310-7440 | SVLHPE-120 Impeller Assembly - High-Pressure | 25 | 819-0016 | Screw (8) |
| | 310-7450 | SVLHPE-130 Impeller Assembly - High-Pressure | | | |
| | 310-7400 | SVLHPS-107 Impeller Assembly - High-Pressure | | | |
| | 310-7410 | SVLHPS-110 Impeller Assembly - High-Pressure | | | |
| | 310-7420 | SVLHPS-115 Impeller Assembly - High-Pressure | | | |
| | 310-7430 | SVLHPS-120 Impeller Assembly - High-Pressure | | | |
| | 310-7440 | SVLHPS-125 Impeller Assembly - High-Pressure | | | |
| | 310-7420 | SVLHPS-215 Impeller Assembly - High-Pressure | | | |
| | 310-7430 | SVLHPS-220 Impeller Assembly - High-Pressure | | | |
| | 310-7440 | SVLHPS-225 Impeller Assembly - High-Pressure | | | |
| 10 | 319-3110B | Pump Seal Set - Viton | | | |
| 11 | 311-1400 | Faceplate | | | |
| 12 | 711-4290 | Faceplate Gasket | | | |

PUMP UNION REPLACEMENT PARTS

| | | |
|---|-----------------|----------------|
| 1 | 415-4211 | 2 ½" Union Nut |
| 2 | 417-5971 | 2" Tailpiece |
| | 417-6001 | 2 ½" Tailpiece |
| 3 | 711-6020 | Gasket |

PUMP UNION ASSEMBLY

| | |
|------------------|--------------------------|
| 400-6021B | 2 ½" Union x 2 ½" Socket |
| 400-5971B | 2 ½" Union x 2" Socket |

2 of each union are included with pump



Waterway™

2200 East Sturgis Road, Oxnard CA 93030 • Phone 805.981.0262 • Fax 805.981.9403

www.waterwayplastics.com • waterway@waterwayplastics.com